

Thermo Scientific

FOCUS GC

Gas Chromatograph

Instruction Manual

PN 31709412, Revision May 2007

HOME



FOCUS™ GC Instruction Manual

May 2007 Edition

Part Number 317 094 12

© 2007 Thermo Fisher Scientific Inc. All rights reserved.

Printed in Italy

Published by Thermo Electron S.p.A., Strada Rivoltana, 20090 Rodano - Milan - Italy

Tel: +39 02 95059355 Fax: +39 02 95059388

Printing History: First Edition, released June 2002

Second Edition, released May 2003

Third Edition, released April 2004

Fourth Edition, released November 2004

Fifth Edition, released January 2005

Sixth Edition, released September 2005

Seventh Edition, released June 2006

Eight Edition, released January 2007

Ninth Edition, released May 2007

Disclaimer

Technical Information contained in this publication is for reference purposes only and is subject to change without notice. Every effort has been made to supply complete and accurate information; however, Thermo Fisher Scientific assumes no responsibility and will not be liable for any errors, omissions, damage, or loss that might result from any use of this manual or the information contained therein (even if this information is properly followed and problems still arise).

This publication is not part of the Agreement of Sale between Thermo Fisher Scientific and the purchaser of a FOCUS™ GC system. In the event of any conflict between the provisions of this document and those contained in Thermo Fisher Scientific's Terms and Conditions, the provisions of the Terms and Conditions shall govern.

Reference to System Configurations and Specifications supercede all previous information and are subject to change without notice.

Trademarks

FOCUS™ GC is a trademark of Thermo Thermo Scientific Inc., and its subsidiaries. Other brand and product names may be trademarks or registered trademarks of their respective companies.

Manufacturer: *Thermo Electron S.p.A.*

Thermo Electron S.p.A. is the manufacturer of the instrument described in this manual and, as such, is responsible for the instrument safety, reliability and performance only if:

- installation
- re-calibration
- changes and repairs

have been carried out by authorized personnel and if:

- the local installation complies with local law regulations
- the instrument is used according to the instructions provided and if its operation is only entrusted to qualified trained personnel

Thermo Electron S.p.A. is not liable for any damages derived from the non-compliance with the aforementioned recommendations.

Thermo Electron S.p.A.

Strada Rivoltana
20090 RODANO (MI)
ITALY

Contents

About This Manual	xiii
Overview	xiii
Conventions Used in This Manual	xv
Instrument Markings and Symbols	xviii
Using the FOCUS GC Document Set	xx
Classification of the Instrument	xxi
Technical Features	xxi
Safety Information	xxii
Use of Gases.....	xxii
Using Hydrogen	xxiii
Using the Hydrogen Sensor	xxiv
Cleaning and Decontamination	xxiv
Chapter 1	
FOCUS GC Description	25
Instrument Overview.....	26
FOCUS GC Components	26
Pneumatic Compartment.....	26
Analytical Unit.....	26
Electronic Compartment	27
Status Panel and Keypad.....	27
Gas Control	27
Carrier Gas Control.....	27
Detector Gas Control	28
Column Oven	28
Injector	28
Split/Splitless (S/SL) Injector	28
Purged Packed Column (PPKD) injector.....	29
Columns	29
Detector	29
Flame Ionization Detector (FID)	29
Thermal Conductivity Detector (TCD).....	30
External Detectors.....	30
Instrument Automation	30
Data Systems Interface.....	30
GC Parts Description.....	31
Front Panel	31
Column Oven	32

Contents

User Interface	32
Electronic Compartment.....	33
Rear Panel.....	35
Carrier Gas Inlet Port.....	36
Detector Gases Inlet Ports	36
Servo Air for Gas Sampling Valve Inlet Port.....	36
Gas Sampling Valve Sample In/Out Ports	37
Electrical Connections.....	37
Oven Exhaust Vent.....	38
Top Panel.....	39
Gas Sampling Valve Overview	40

Chapter 2

The FOCUS GC User Interface	41
Overview.....	42
The Display.....	42
The Display LEDs	44
The FOCUS GC Keypad	45
Parameters Entry	46
User Interface Main Menu.....	47
Oven.....	47
Inlet.....	48
Carrier.....	48
Detector	48
No Detector	49
External Detector.....	49
Signal.....	49
External Detector.....	50
Autosampler.....	50
Sequence.....	50
Others.....	51
Configuration.....	51
When to Configure	51
Configuration Menu.....	52
Oven Configuration Menu.....	53
Carrier Configuration Menu	54
Detector Configuration Menu.....	55
Autosampler Configuration Menu.....	56

AS 2000 Autosampler.....	56
AI 3000/AS 3000	56
Messages	57
General Configuration Menu	58
Keyboard & Display Configuration Menu.....	58
Beep Table	59
Handshake Configuration Menu	60
Time Configuration Menu	61
Valves Configuration Menu.....	61
Run Time Events.....	62
Run-Log	64
Time	66
Valves.....	67
Info/Diagnostics	68

Chapter 3

Gas Control	71
Gas Supplies.....	72
Carrier Gas Regulation.....	75
Detector Gas Regulation	75
Measuring Gas Flow	78
Carrier Gas Parameters	80
Flow Mode	80
Constant Flow	80
Constant Pressure.....	80

Chapter 4

Column Oven	83
Column Oven Overview	84
Oven Safety.....	85
Column Oven Configuration.....	86
Oven Parameters	87

Chapter 5

Split/Splitless Injector (S/SL)	93
S/SL Overview	94
Septum	97
Liners	97

Contents

Packed Columns	98
S/SL Injection Techniques.....	101
Split Injection Technique.....	101
Splitless Injection Technique.....	103
Refocusing the Sample	105
Flooding.....	106
S/SL Inlet Parameters	107
Chapter 6	
Purged Packed Column Injector (PPKD)	113
PPKD Overview	114
Septa	116
Liners	116
PPKD Injection Techniques	116
PPKD Injector Menu	116
Chapter 7	
Column	125
Introduction.....	126
Capillary and Wide-bore Columns	126
Using Correct Fittings	126
Column Ferrules	126
Packed Columns	128
Metric Packed Columns.....	128
Using Correct Metric Fittings.....	128
Imperial Packed Columns.....	129
Using Correct Imperial Fittings.....	129
Installation	132
Keeping Leaks Under Control	146
Column Evaluation	146
Identifying and Removing Leaks	146
Expected K Factor	150
K Factor Tables	150
Helium Carrier Gas Theoretical K Factor	151
Nitrogen Carrier Gas Theoretical K Factor	152
Hydrogen Carrier Gas Theoretical K Factor	153
Column Conditioning	156

Chapter 8

Flame Ionization Detector (FID)	157
FID Overview.....	158
Detector Base Body	158
Detector Gas.....	159
Jet	159
Selectivity.....	160
Temperature	160
FID Gas Supplies	161
FID Installation	162
FID Menu	164
Flame Out Conditions	165
Detector Signal Parameters	166

Chapter 9

Thermal Conductivity Detector (TCD)	171
TCD Overview	172
TCD Gas Supplies.....	174
Columns	175
TCD Operating Modes.....	175
Constant Temperature	175
Constant Voltage.....	175
Selecting TCD Operating Parameters	177
Using the CT Mode.....	177
Using the CV Mode	177
Suggested Operating Values	178
TCD Menu	179
Detector Signal Parameters	181

Chapter 10

Autosamplers	187
Autosampler Overview	188
Sequence of Sample.....	188
Autosampler Configuration.....	189
Autosampler Menu.....	189
AS 2000 Autosampler Menu.....	190
Internal Standard Use.....	192
AI 3000/AS 3000 Menu	193

Contents

Sequence Programming	195
Chapter 11	
Getting Started	197
Instrument Set-up.....	198
Run Time Events	202
Controlling Valves.....	206
Run Time Control (Gas Sampling Valve Only)	206
Manual Control.....	206
Instrument Start-Up	208
Instrument Status Messages.....	211
Not Ready	211
Stand-By	212
Prep-Run	212
Ready to Inject.....	213
Ready to Inject with an Autosampler enabled.....	213
Run.....	213
Chapter 12	
Checkout Using FID with S/SL	215
SOP number: P0407/05/E - 31 May 2006	216
Scope	216
Preliminary Operations.....	216
Parts Referenced.....	218
Analytical Conditions Required for FID-S/SL.....	219
Chapter 13	
Checkout Using TCD with S/SL	229
SOP number: P0473/04/E - 02 May 2007	230
Scope	230
Preliminary Operations.....	230
Parts Referenced.....	232
Analytical Conditions Required for TCD-S/SL	233
Chapter 14	
Checkout Using TCD with PPKD	243
SOP number: P0474/05/E - 02 May 2007	244
Scope	244
Preliminary Operations.....	244

Parts Referenced	246
Analytical Conditions Required for Splitless Injection	248

Chapter 15

Maintenance and Troubleshooting 257

Maintenance	259
How To Perform Maintenance.....	259
Suggested Maintenance Schedule	259
Septa.....	259
Ferrules and Seals	260
Traps	260
Detector Unit.....	260
Maintenance Schedule Table	260
Instrument Cleaning	261
Maintaining a SSL Injector	262
When Replacing the Standard Septum.....	262
When Cleaning or Replacing the Liner.....	262
If the Glass Liner Breaks Inside the Injector	263
Related Operating Sequences.....	263
Maintaining a PPKD Injector.....	276
When replacing the septum.....	276
When replacing the liner	276
Maintaining a FID	282
FID Troubleshooting.....	295
Change in Sensitivity	295
Gases	295
Flame Ignition.....	296
Maintaining a TCD	298
TCD Troubleshooting	300
Sensitivity.....	300
Baseline drift.....	300
Negative peaks	300
Troubleshooting the TCD	301
Maintaining Gas Sampling Valve	304
Analytical Troubleshooting.....	306
Instrument Troubleshooting.....	307
Error Messages.....	307
Guide to Solve Analytical Problems	309

Contents

Chapter 16

LAN Option Set-up	321
Introduction.....	322
IP Address and LAN Communication Port	322
Reset Button	323
Network Cables	323
Set-Up	324

Appendix A

Customer Communication	337
How To Contact Us	337
Reader Survey.....	338

Glossary	339
-----------------------	------------

Index	345
--------------------	------------

About This Manual

Overview

This *Operating Manual* contains descriptions of the features and components of the FOCUS GC gas chromatograph. Inside, you will find all of the information necessary for routine operation of your GC, including operating sequences, sample injection techniques, and diagrams and descriptions of the major components.

Chapter 1, *FOCUS GC Description*, provides a basic overview of the features and options of the FOCUS GC gas chromatograph. After each brief description of a FOCUS GC component, you will find references to chapters in this manual containing more detailed information.

Chapter 2, *The FOCUS GC User Interface*, provides basic information about key functions and menus. This chapter contains also instructions to set up the software on your GC either to match the installed hardware or to reflect your preferences.

Chapter 3, *Gas Control*, contains information on controlling and programming the carrier and detector gas flows to the FOCUS GC.

Chapter 4, *Column Oven*, describes the features of the FOCUS GC column oven.

Chapter 5, *Split/Splitless Injector (S/SL)*, describes the Split/Splitless (S/SL) injector and contains operating sequences for the different split/splitless operating modes.

Chapter 6, *Purged Packed Column Injector (PPKD)*, describes Purged Packed Column (PPKD) injector.

Chapter 7, *Column*, describes the analytical columns installed in the FOCUS GC oven.

Chapter 8, *Flame Ionization Detector (FID)*, describes the Flame Ionization Detector.

Chapter 9, *Thermal Conductivity Detector (TCD)*, describes the operating principles and sequences for the Thermal Conductivity Detector (TCD).

Chapter 10, *Autosamplers*, describes how to program and control the AS 2000 autosampler and the AI 3000/AS 3000 by using the FOCUS GC keypad. This chapter contains also the instructions to programming a sample sequence with the FOCUS GC keypad when an AS 2000 or an AI 3000/AS3000 is used and how to set up ranges of samples to run automatically.

Chapter 11, *Getting Started*, contains instructions to operate with your FOCUS GC through the instrument keypad. We also included instructions to program a Run Time Events and the instrument start-up.

Chapter 12, *Checkout Using FID with S/SL*, contains the operating procedure to check the Flame Ionization Detector with the Split/Splitless Injector (S/SL).

Chapter 13, *Checkout Using TCD with S/SL*, contains the operating procedure to check the Thermal Conductivity Detector (TCD) with the Split/Splitless Injector (S/SL).

Chapter 14, *Checkout Using TCD with PPKD*, contains the operating procedure to check the Thermal Conductivity Detector (TCD) with the Purged Packed Injector (PPKD).

Chapter 15, *Maintenance and Troubleshooting*, contains information and operating sequences to perform the necessary maintenance of the instrument and also information concerning troubleshooting in case of malfunctioning.

Chapter 16, *LAN Option Set-up*, contains notes on how to set-up and start using the FOCUS GC with the LAN (Local Area Network) option.





Appendix A, *Customer Communication*, contains contact information for Thermo Fisher Scientific offices worldwide. Use the *Reader Survey* in this section to give us feedback on this manual and help us improve the quality of our documentation.

The *Glossary* contains definitions of terms used in this manual. This also includes abbreviations, acronyms, metric prefixes, and symbols.

The *Index* contains an alphabetical list of key terms and topics in this guide, including cross references and the corresponding page numbers.

Conventions Used in This Manual

The following symbols and typographical conventions are used throughout this manual.

Bold	Bold text indicates names of windows, dialog boxes, and fields.
<i>Italic</i>	Italic indicates cross references, first references to important terms defined in the glossary, and special emphasis.
Monospace	Monospace, or Courier, indicates filenames and filepaths or text the user should enter with the keyboard.
Monospace Bold	Monospace Bold indicates messages, prompts, or menu titles displayed on the computer screen or on a digital display.
»	This symbol illustrates menu paths to select, such as File»Open....
KEY NAME	Bold, uppercase sans serif font indicates the name of a key on a keyboard or keypad, such as ENTER .
 CAUTION	This symbol alerts you to an action or sequence that, if performed improperly, could damage the instrument.
 NOTE	This symbol alerts you to important information related to the text in the previous paragraph.
 WARNING!	This symbol alerts you to an action or sequence that, if improperly performed, could result in damage to the instrument or possible physical harm to the user. This symbol may be followed by icons indicating special precautions that should be taken to avoid injury.
	This symbol indicates an electric shock hazard.



This symbol indicates danger from hazardous chemicals.



This symbol indicates danger from high temperature surfaces or substances.



This symbol indicates a fire hazard.



This symbol indicates an explosion hazard.



This symbol indicates a toxic hazard.



This symbol indicates the presence of flammable materials.



This symbol indicates the presence of radioactive material.



This symbol indicates an operation or sequence that must *not* be performed by the user. A Thermo Fisher Scientific authorized Customer Support Engineer must perform this sequence.



This symbol indicates all metal objects, such as watches and jewelry, must be taken off.



This symbol indicates an eye hazard. Eye protection must be worn.



This symbol indicates the user must wear a protective screen when performing the sequence.



This symbol indicates the user must wear protective shoes when performing the sequence.











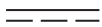

This symbol indicates the user must wear protective clothing when performing the sequence.











This symbol indicates the user must wear gloves when performing the sequence.

Instrument Markings and Symbols

The following table explains the symbols used on Thermo Fisher Scientific instruments. Only a few of them are used on the FOCUS GC gas chromatograph.

Symbol	Description
	Direct Current
	Alternating Current
	Both direct and alternating current
	Three-phase alternating current
	Earth (ground) terminal
	Protective conductor terminal
	Frame or chassis terminal
	Equipotentiality
	On (Supply)
	Off (Supply)

Symbol	Description
	Equipment protected throughout by DOUBLE INSULATION or REINFORCED INSULATION (Equivalent to Class II of IEC 536)
	Indicates that the user must refer to the manual for specific Warning or Caution information to avoid personal injury or damage to the product.
	Caution, risk of electric shock
	Caution, hot surface
	Caution (refer to accompanying documents)
	In-position of a bistable push control
	Out-position of a bistable push control
	Symbol in compliance to the Directive 2002/96/EC on Waste Electrical and Electronic Equipments (WEEE) placed on the european market after August, 13, 2005.

Using the FOCUS GC Document Set

The FOCUS GC Document Set (CD-Rom PN 317 095 00) includes all manuals in electronic format, and serves as your library for information about the FOCUS hardware and software.

The FOCUS GC Document Set (PN 317 094 10) as paper copy is also available. Furthermore, Thermo Fisher Scientific part numbers (PN) for the paper copy manuals are provided for each book title.

Site Preparation and Installation Manual (PN 317 094 11)

This manual and diskette describes how to set up a workspace for the FOCUS GC and how to connect the FOCUS GC to the gas supplies and peripheral devices.

FOCUS GC Instruction Manual (PN 317 094 12)

This manual provides descriptions of the FOCUS GC hardware and software and instructions for their use.

Spare Parts Catalog (PN 317 094 13)

This catalog contains a list of spare parts for the FOCUS GC.

Classification of the Instrument

Environmental Conditions

- Internal use.
- Altitude up to 2000 meters.
- Temperature from 15 to 35 °C.
- Maximum relative humidity between 30% and 85%.
- Voltage variations not exceeding% of the nominal value.
- Transients according to installation categories II.
- Degree of pollution according to IEC 664 (3.7.3) 2.

Technical Features

The following table summarizes the major technical features of the FOCUS GC

- External Interface
 - RS232 Serial Line
 - LAN (Optional)
- Power Supply
 - 120 Vac; 50/60 Hz; 1600 VA
 - 230 Vac; 50/60 Hz; 1600 VA
- Dimensions
 - 680 x 640 x 440 mm (h x l x w)
- Mass
 - About 30 kg

Safety Information



WARNING! The instrument must be used according to the specifications of this guide. Improper use can adversely affect the instrument protection. The analytical operation requires the use of chemical substances having different hazard specifications. Before using chemicals, please read the hazard indications and information reported in the Safety Sheet supplied by the manufacturer referring to the relevant CAS (Chemical Abstract Service) number.

Use of Gases



WARNING! Before using gases, carefully read the hazard indications and information reported in the Safety Sheet supplied by the manufacturer referring to the CAS (Chemical Abstract Service) number. It is the user's responsibility to see that all local safety regulations for the use of gases are obeyed.

Using Hydrogen

The use of hydrogen as a carrier gas or as fuel for certain flame detectors requires the operator's strict attention and compliance with special precautions due to the hazards involved.

Hydrogen is a dangerous gas, particularly in an enclosed area when it reaches a concentration corresponding to its lower explosion level (4% in volume). When mixed with air it can create an explosive mixture. An explosion hazard could develop in the GC oven when hydrogen is used as a carrier gas if oven elements are not perfectly connected to each other, or if the connection materials are worn out, broken, or otherwise faulty.

Use the following safety precautions when using hydrogen:

- Ensure that all hydrogen cylinders comply with the safety requirements for proper use and storage. Hydrogen cylinders and delivery systems must comply with local regulations.
- Make sure the gas supply is turned completely off when connecting hydrogen lines.
- Perform a *bubble test* to ensure that the hydrogen lines are leak-tight before using the instrument. Perform this test after the pressure test described in the **Testing for Leaks** paragraph in *FOCUS GC Site Preparation and Installation Guide Manual*. Repeat this test to eliminate all leaks.
- Ensure your GC column oven has a Thermo Fisher Scientific hydrogen sensor. The hydrogen sensor continuously monitors the hydrogen level in the GC column oven.

If your GC oven does not have a hydrogen sensor already installed, contact your Thermo Fisher Scientific sales representative. To comply with instrument safety requirements, a Thermo Fisher Scientific CSE or authorized service technician should install the sensor.

If you plan to use a sensor other than the recommended Thermo Fisher Scientific sensor, you must verify its ability to perform the functions listed above before installing it. It must comply with your local safety regulations, or with the IEC 61010 regulations if local regulations do not exist.

Using the Hydrogen Sensor

The lower limit of the hydrogen sensor is 0.5% in volume. You should adjust the detection threshold to 1% in volume, which is 25% of the hydrogen lower limit of explosion (4% in volume). In cases where the connections begin to leak or the column breaks, the sensor alerts the operator. Then it automatically cuts off the gas supply and heating to the active zones, and sweeps the column oven with forced air ventilation. If the sensor detects anomalies or leaks during GC operation due to instrument malfunction, the operator must immediately:

- close the hydrogen supply
- switch off the gas chromatograph
- air out the room

The reliability of the sensor depends on careful maintenance. After the sensor is in use, you must periodically check its operating performance and calibration as recommended by the manufacturer. Refer to your hydrogen sensor's instruction manual for maintenance guidelines.



WARNING! Never use hydrogen in FOCUS GC unless your GC oven has a hydrogen sensor installed.

Thermo Fisher Scientific CSEs are not authorized to install or repair any instrument using hydrogen as a carrier gas unless the instrument is equipped with the appropriate sensor.

Cleaning and Decontamination

Normal usage of the FOCUS GC can cause the exterior to get dirty. Clean the outer surfaces by wiping them with a cloth dampened with water.

In the event that a hazardous material is spilled on or in the instrument, clean the spill according to the procedures in the Material Safety Data Sheet for that substance.

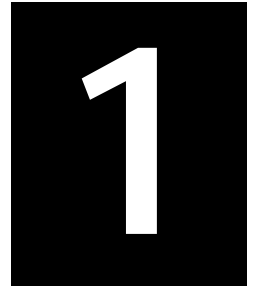

FOCUS GC Description

This chapter provides a basic overview of the features and options of the FOCUS GC gas chromatograph. After each brief description of a FOCUS GC component, you will find references to chapters in this manual containing more detailed information.

Chapter at a Glance...

Instrument Overview	26
GC Parts Description	31

Instrument Overview

The FOCUS GC consists of four major components, as shown in Figure 1-1.

FOCUS GC Components

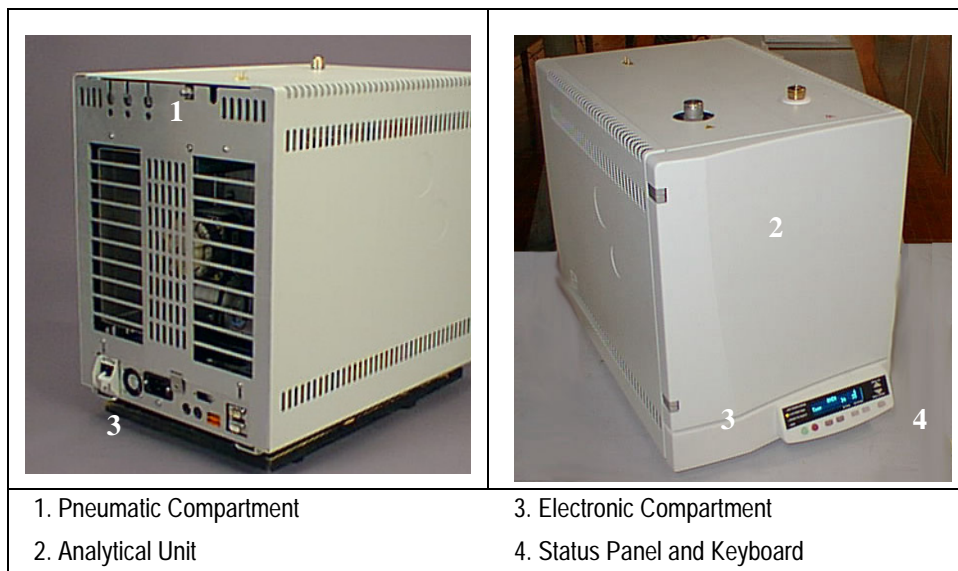

Figure 1-1. FOCUS GC Components

Pneumatic Compartment

The pneumatic compartment contains the pneumatic gas control circuits. The carrier gas control circuit is completely electronic (digital pneumatics), while the detector gas control circuit is conventional (analog pneumatics)

Analytical Unit

The analytical unit consists of two subcompartments:

- the column oven
- the injector and detector compartment

Electronic Compartment

The electronic compartment consists of two subcompartments:

- the high-voltage compartment
- the low voltage compartment

Status Panel and Keypad

The status panel and the keypad make up the FOCUS GC user interface.

Gas Control

The GC is equipped with digital pneumatics for carrier gas control and conventional pneumatics for detector gases control.

Carrier Gas Control

Carrier gas is controlled electronically through an electronic pneumatic control module Digital Pressure Flow Control (DPFC) mounted in the pneumatic compartment.

DPFC Module

The DPFC module features the following:

- constant pressure or constant flow operating modes
- inlet pressure control (in kPa, psi, or bar) and column flow rate control (in mL/min)
- split flow control (in mL/min)
- septum purge flow control (in mL/min)

The DPFC module also allows the following operations:

- **Column Evaluation**
To to automatically calculate the column constant.
- **Leak Check**
To keep the system under control.
- **Gas Saver Function**
To reduce the split flow after an injection to avoid the waste of expensive gases.

Detector Gas Control

Detector gases are controlled through a conventional pneumatic control module (DGFC) mounted in the pneumatic compartment. The pneumatic circuits have three flow regulators in case of an FID and two flow regulator in case of a TCD. The adjustment is done in factory prior shipment, and remains always at the set flow. DGFC gas flow can be automatically switched on and off by using the FOCUS GC keypad.

Refer to...

Chapter 3, *Gas Control*.

Column Oven

The FOCUS GC column oven has a high degree of thermal stability and fast heating and cooling. The air circulation in the oven ensures the column is kept in a thermally homogenous and stable zone. This provides more precise analytical performance and helps prevent chromatogram peak distortion.

Refer To...

Chapter 4. *Column Oven*.

Injector

FOCUS GC is designed to operate with the following injectors:

Split/Splitless (S/SL) Injector

This injector minimizes heavy component discrimination with optimized sample transfer to the column. You can use capillary and wide-bore columns with the

Split/Splitless injector. With the appropriate adapter kit, you can also use packed columns.

Refer to...

Chapter 5, *Split/Splitless Injector (S/SL)*

Purged Packed Column (PPKD) injector

This injector allows sample injection and vaporization into a liner. The sample then transfers to an analytical column.

Refer to...

Chapter 6...*Purged Packed Column Injector (PPKD)*

Columns

The column is where the chromatographic separation of the sample occurs. Several types of columns are available for different chromatographic applications:

- capillary columns
- wide-bore capillary columns
- packed column

Refer to...

Chapter 7, *Column*

Detector

FOCUS GC is designed to operate with the following detectors:

Flame Ionization Detector (FID)

This is one of the most used detectors in GC because of its high sensitivity, good stability and wide range of linearity of response. The FID ensures stable, reproducible, and long-term trouble-free performance.

Refer to...

Chapter 8, *Flame Ionization Detector (FID)*

Thermal Conductivity Detector (TCD).

The TCD is a universal type detector. It is used in the analysis of permanent gases and other compounds for which the FID is non-sensitive.

Refer to...

Chapter 9, *Thermal Conductivity Detector (TCD)*

External Detectors

FOCUS GC may also operate with **external detectors**. An external detector is a detector controlled by an external control module. The FOCUS GC only provides the heating through the base body, the gas supply and the signal analog to digital conversion for acquisition.

Instrument Automation

FOCUS GC contains several automated features for running the GC, communicating with other analysis equipment, and interacting with a data system.

Autosampler Interface

The TriPlus, AI 3000/AS 3000, AS 2000 or HS 2000 autosampler can be connected to the GC.

Refer to...

Chapter 10, *Autosamplers*

Data Systems Interface

Your FOCUS GC generates analog and digital data output when you perform chromatographic analysis. A computer with a Thermo data system or a computing integrator can be used to process the data from the GC.

GC Parts Description

This paragraph gives you a detailed description of the instrument components.

Front Panel

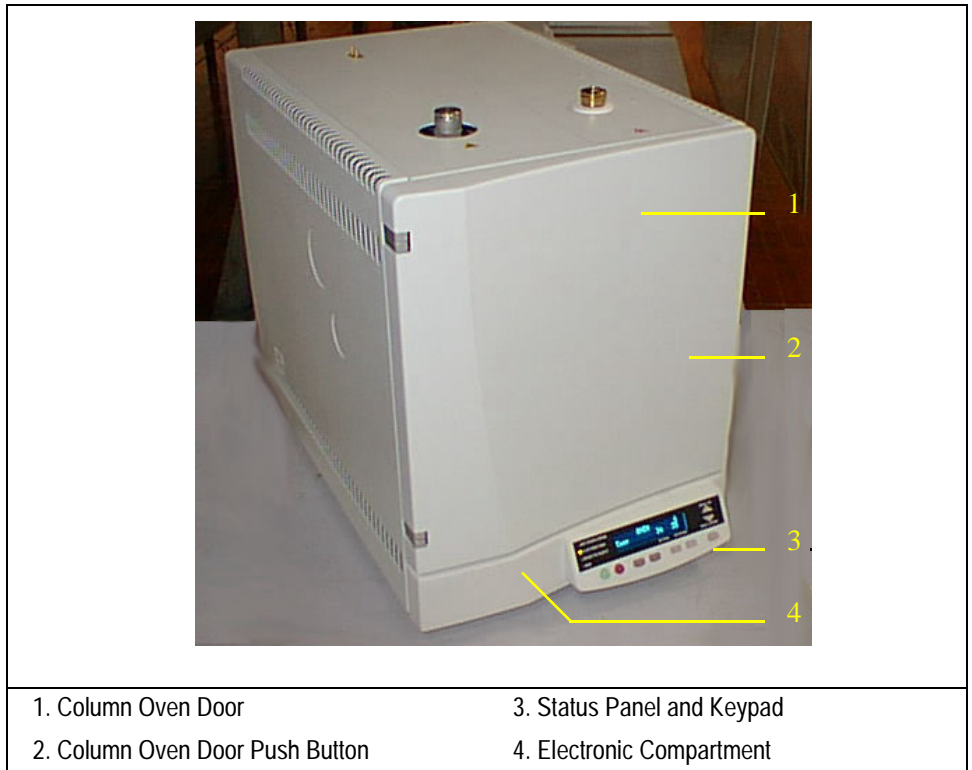

Figure 1-2. FOCUS GC Front Panel

It comprises:

- Column Oven
- Status Panel and keypad
- Electronic Compartment

Column Oven

The FOCUS GC column oven, shown in Figure 1-3, is accessible opening the column oven door by pushing the relevant button.

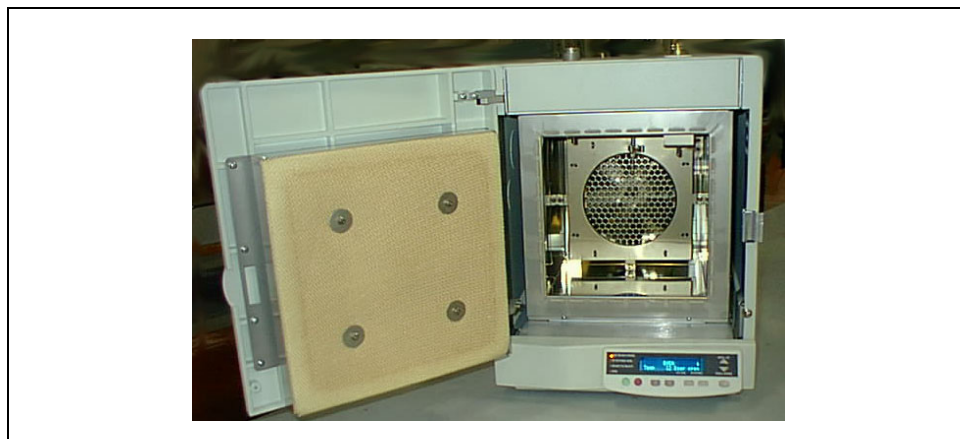

Figure 1-3. Column Oven Internal View

Refer To...Chapter 4, [Column Oven](#)

User Interface

User interface, shown in Figure 1-4, has three components; a two-line display, display LEDs showing the instrument's status and a keypad for data entry.

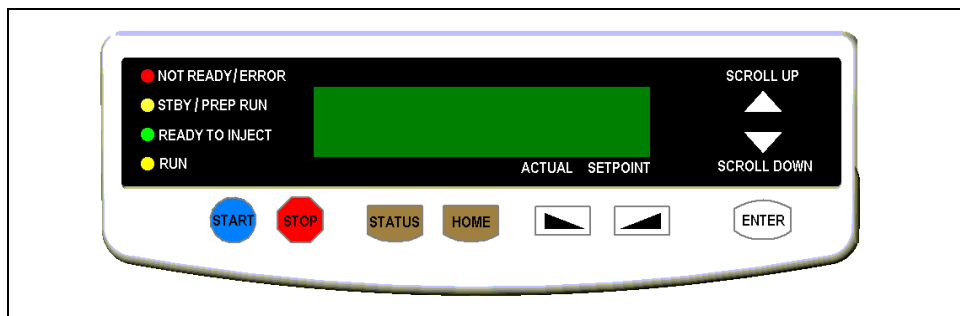

Figure 1-4. FOCUS GC User Interface

Refer To...Chapter 2, [The FOCUS GC User Interface](#)

Electronic Compartment

It is located on the bottom part of the GC, and it is accessible only by authorized Thermo Fisher Scientific technical personnel.



WARNING! Before opening the electrical compartment, cut off power supply to the instrument and disconnect the power cord.

The electronic compartment, shown in Figure 1-5, comprises:

- Low Voltage Section
- Mains Voltage Section



Figure 1-5. Example of Electronic Compartment

Low Voltage Section

It contains the electronic circuits to operate and control the instrument.



WARNING! A Li 3 V; 220 mA/h un rechargeable battery is present on the Main Board. The battery replacement must be performed only by specialized technical personnel.

High Voltage Section

It contains the mains power circuits. The configuration of the instrument 120 or 230 Vac power supply is determined by the position of the voltage selector,

factory set, located on the Main Board. According to the instrument power supply configuration, the breaker ON/OFF main switch changes as follows:

Power Supply	Breaker
120 Vac	15A
230 Vac	7A

The high voltage section is provided of a series of protection fuses as reported in the following table:

Fuse	Type	Protection
F1	F2A; IEC 127/I; (5 x20 mm)	Injector heater element
F2	T1.6A; IEC 127/III; (5 x20 mm)	230 Vac Main power (Breaker) 120 Vac Main power (Breaker)
F3	F2A; IEC 127/I; (5 x20 mm)	Auxiliary heater element
F4	F0.63A; IEC 127/I; (5 x 20 mm)	Oven fan motor
F5	F0.63A; IEC 127/I; (5 x 20 mm)	Oven fan motor

Rear Panel

The FOCUS GC Rear Panel is shown in Figure 1-6.

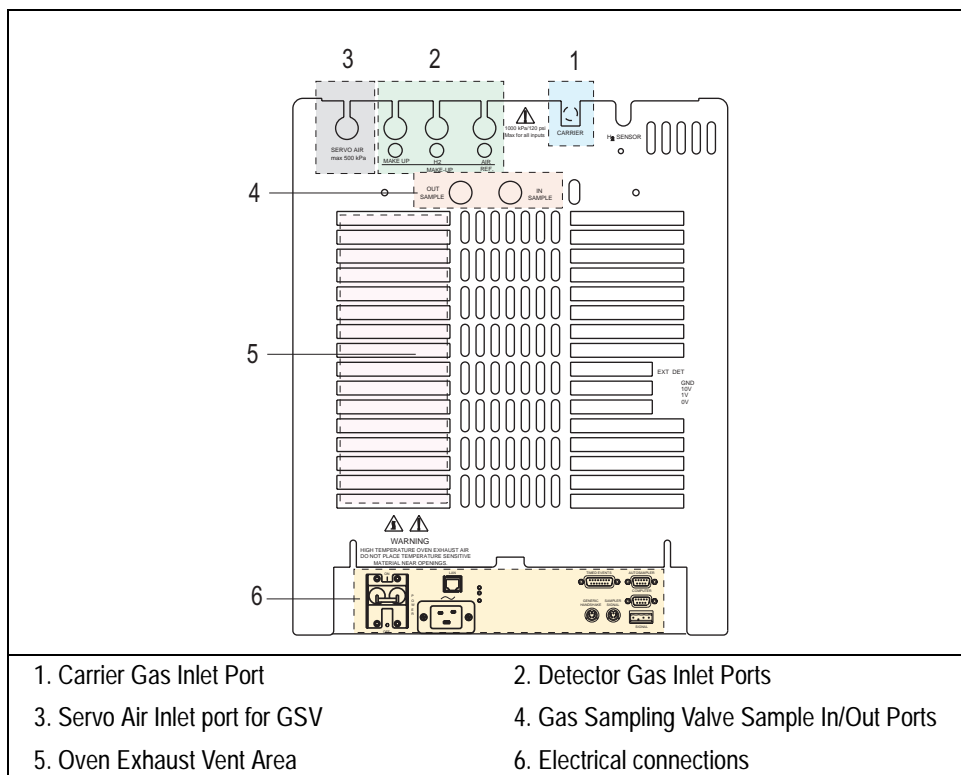

Figure 1-6. Rear Panel

It comprises

- Carrier Gas inlet port
- Detector Gas inlet ports
- Servo Air inlet port for Gas Sampling Valve (GSV) when present
- Gas Sampling Valve Sample In/Out ports
- Oven Exhaust Vent
- Electrical Connections

Carrier Gas Inlet Port

It is located on the middle upper part of the instrument rear panel. Gas inlet port are directly connected to the detector modules.



WARNING! Gas pressure must be controlled on the gauges provided on the gas tank of the supply gas line. The maximum inlet pressure at 1000 kPa (145 psi) should be set to allow DPFC module to adjust pressure up to 1000 kPa.

Commonly used gas are helium, hydrogen and nitrogen.

The default pressure unit is the kilopascal (kPa). You specify the pressure units in the **Configuration** menu.

The following gives a brief conversion guide for the most commonly used pressure units.

To Convert	To	Multiply by
kPa	bar	0.01
	psi	0.145
bar	kPa	100
	psi	14.51
psi	kPa	6.89
	bar	0.0689

$$100 \text{ kPa} = 1 \text{ bar} = 14.51 \text{ psi}$$

Detector Gases Inlet Ports

They are located on the middle upper part of the instrument rear panel. Detector gas inlet ports are directly connected to the DGFC module.



WARNING! Pressure of the supply gas lines should be set to a minimum of 400 kPa (60 psi) to ensure the regulation of detector gases.

Maximum input pressure to FOCUS GC (from supply gas lines) is 1000 kPa (145 psi).

Servo Air for Gas Sampling Valve Inlet Port

It is located on the left upper part of the instrument rear panel. Servo air inlet port is directly connected to the gas sampling valve when installed into the GC.



WARNING! Pressure of the servo air supply line should be set to a maximum of 500 kPa (72 psi).

Gas Sampling Valve Sample In/Out Ports

They are located on the middle upper part of the instrument rear panel. These ports are directly connected to the gas sampling valve, when installed into the GC, for the automatic sampling of gas.

For further details, refer to [Gas Sampling Valve Overview](#).

Electrical Connections

Electronic connections are located on the rear part of the electronic compartment. As shown in Figure 1-7.

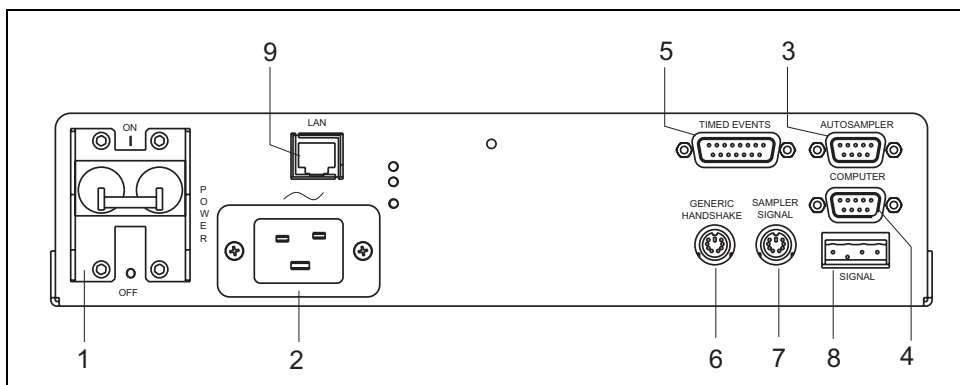
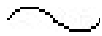

Figure 1-7. Electrical Connections

1. Breaker marked **POWER** to switch the instrument On/Off
 - Position **I** = instrument ON
 - Position **O** = instrument OFF
2. 120 or 230 Vac 50/60 Hz Main socket marked 
3. 9-pin connector marked **AUTOSAMPLER** to dialog with an autosampler (TriPlus, AI 3000/AS 3000, AS 2000 or HS 2000) via RS232 serial line.

4. 9-pin connector marked **COMPUTER** to dialog with the computer via RS232 serial line (only if LAN option not installed).
5. 15-pin connector marked **TIMED EVENTS** to automatically drive up to external valves.
6. 8-pin connection marked **GENERIC HANDSHAKE** to synchronize with external devices.
7. 6-pin connector marked **SAMPLER SIGNALS** for the autosampler Start/Stop signals.
8. 4-pin connection marked **SIGNAL 0–1V-10V-GND** for the detector analog signal output.
9. Option marked **LAN** (Local Area Network) for the network connection of the FOCUS GC LAN (only if LAN option installed)

LAN Option

The FOCUS LAN is easily recognizable by the presence on the GC rear panel of a RJ45 connector, 2 LEDs for LAN activity and a reset button.

The FOCUS LAN sampler is shipped with a default IP address, which may not match the LAN needs of the sites where the sampler must be installed. To change the default values, contact your LAN administrator and ask for the IP address to be assigned, the netmask, and eventually the port. The IP address and communication port may be reset to default value by pushing the reset button, accessible from the rear panel of the FOCUS GC, for at least 5 seconds.



CAUTION

The reset button is accessible introducing a little screwdriver into the relevant passing hole.

To set the IP address and the LAN communication port, follow the instructions reported in Chapter 14 *LAN Option Set-up*.

Oven Exhaust Vent

Hot air [350°C (660°F)] exits through this vent during GC operation.

Any material exposed to the oven exhaust must be able to withstand repeated exposure to temperatures of up to 350°C (660 °F).



WARNING! Oven exhaust can cause severe burns. Avoid working behind the instrument when the oven vents during cooling-down cycles. Do not expose gas tanks or bottles, chemicals, regulators, electrical cords, or other temperature-sensitive items to oven exhaust.

Top Panel

Top panel is shown in Figure 1-8.

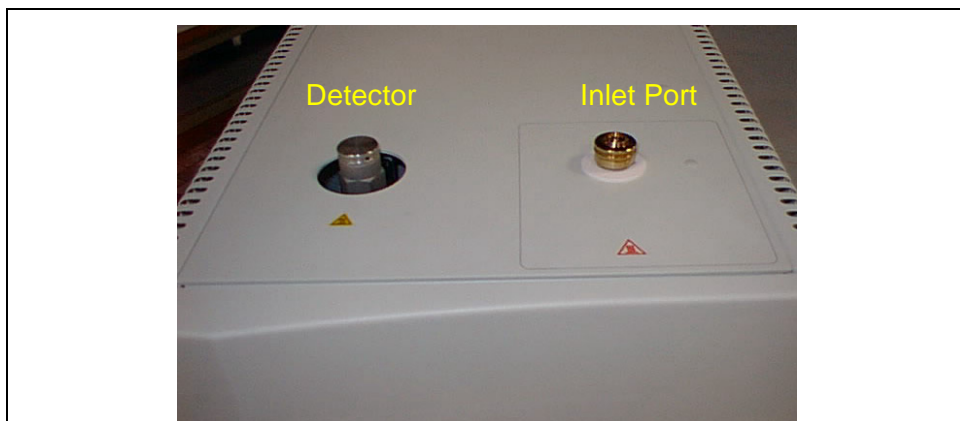

Figure 1-8. Top Panel

It comprises:

- S/SL or PPKD injector port
- Split and Purge lines vent
- FID or TCD detector

For details refer to the following Chapters:

- *Split/Splitless Injector (S/SL)*
- *Purged Packed Column (PPKD) injector*
- *Flame Ionization Detector (FID)*
- *Thermal Conductivity Detector (TCD)*

Gas Sampling Valve Overview

A valve for the automatic sampling of gas is available with the FOCUS GC. The valve is installed behind the injector/detector compartment of the GC. The valve is not heated.

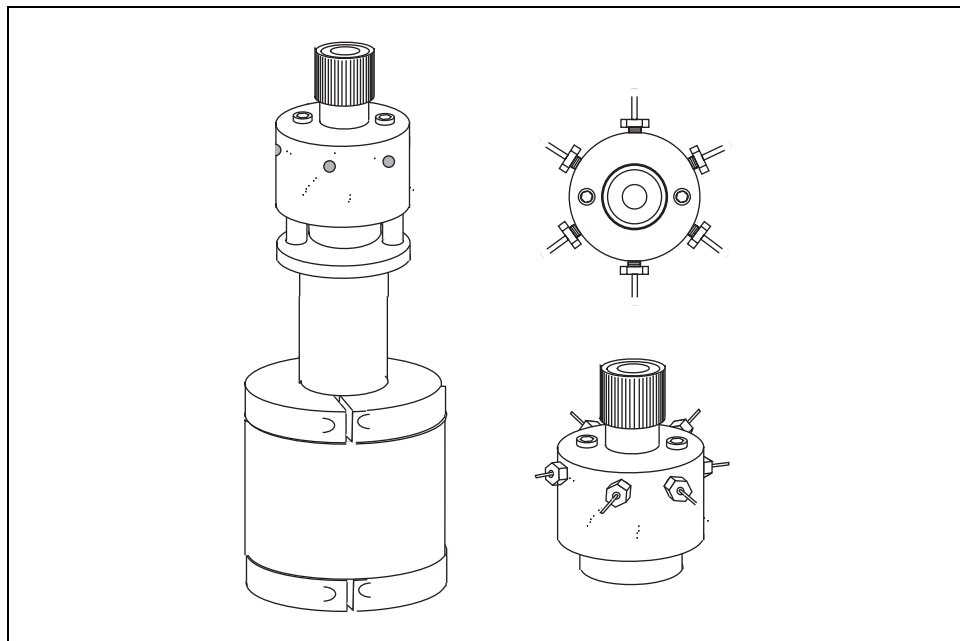

Figure 1-9. Gas Sampling Valve

For the automatic gas sampling, a 6-port valve is used. A wide range of sampling loops allows the analysis of different sample volumes.



NOTE

A sampling loop with 1 mL of volume is provided in the standard outfit.

The sampling loop is installed directly on the valve. The switching between **load sample** and **inject sample** position (and vice-versa) is controlled through the FOCUS GC keypad or through the GC method created with the data system.

To install/replace the sampling loop, please refer to the chapter [Maintenance and Troubleshooting](#) in this manual.



The FOCUS GC User Interface

FOCUS GC user interface, provides basic information about key functions and menus. This chapter contains also instructions to set up the software on your GC either to match the installed hardware or to reflect your preferences.

Chapter at a Glance...

Overview	42
User Interface Main Menu.....	47
Configuration.....	51
Configuration Menu	52
Run Time Events	62
Run-Log.....	64
Time.....	66
Valves	67
Info/Diagnostics	68

Overview

The user interface has three components:

- two line display
- display LEDs showing the instrument's status
- a keypad for data entry.

Figure 2-1 illustrates the complete FOCUS GC user interface.

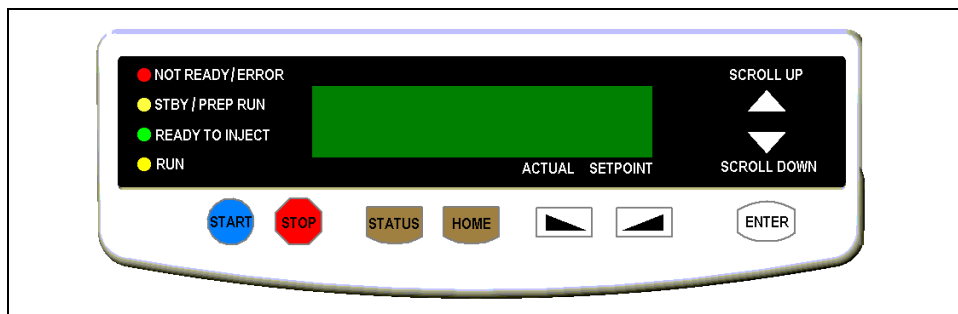

Figure 2-1. The FOCUS GC User Interface

The Display

The display shows the menus you use to control the GC parameters, settings, and configuration options. The data entry keys allow you to scroll through, set, and modify the menu information.

Figure 2-2 shows the components of a typical menu display.

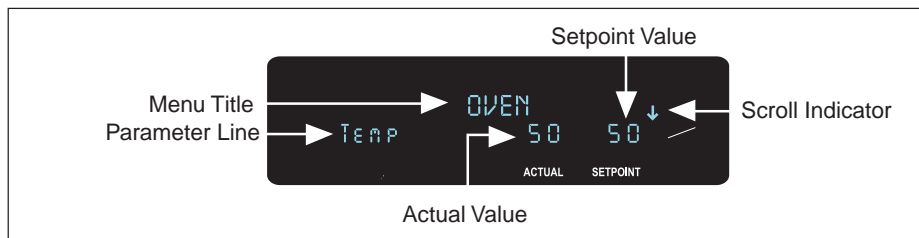

Figure 2-2. Components of the FOCUS GC Menu Display

The following are the menu display components:

Menu Title—This is the first line of each menu. The menu title is always visible when scrolling through the menu items.

Cursor—The cursor indicates the currently selected menu item. Use the **UP ARROW** and **DOWN ARROW** keys to move the cursor.

Setpoint Value and Actual Value—Many parameters display two values. The first value is the actual value of the GC parameter. You enter the second value, which is the setpoint that is edited.

Scroll Indicator—This item is found in the upper right corner of the display. It indicates that not-currently visible menu items exist. It appears in three ways:

- ↓, indicating that you can scroll downward
- ↑, indicating that you can scroll upward
- ↕, indicating that you can scroll in either direction

Currently Visible Menu Parameters—The display shows four lines of a menu at a time. Because the menu title always takes up the first line, three lines show menu items.

Not Currently Visible Menu Parameters—The display shows three menu items at a time. If a menu contains more than three lines, you can use the arrow keys to scroll through the rest of the menu items.

The Display LEDs

The LEDs (Light Emitting Diodes) on the left side of the display screen indicate the FOCUS GC's operating status.

The status LEDs indicate the current operating mode and special settings activated by the operator. Table 2-1 lists and explains each status LED.









Table 2-1. Status LED Descriptions

LED	Description
Not Ready/Error	This LED lights when the GC is not ready to make a run, for example when the setpoint oven temperature has not been reached. It remains lit if any additional equilibration time has been configured. It blinks when the GC has one or more error conditions.
Standby/Prep Run	This LED lights when the GC is in Standby , waiting to be advanced to the Ready status. It blinks when the GC prepares for a run, for example, during switching of valves required by the method or waiting for an external device such as a mass spectrometer.
Ready to Inject	This LED lights when the prep run has finished, indicating that you can inject a sample or start an autosampler.
Run	This LED lights when the run is in progress.

The FOCUS GC Keypad

The following Table lists and describe the keys on the FOCUS GC Keypad.

Table 2-2. Keypad Descriptions

Key	Description
	The blue START key is a double function key. When pressed a first time it starts the PREP RUN function. When pressed a second time, it starts a run with programmed parameters after you manually inject a sample into the inlet. When a remote start by another device, such as an autosampler, has been programmed, the system automatically starts after injection.
	The red STOP key has the following functions: - stops a run in progress - resets the FOCUS GC from READY to NOT READY
	The STATUS key displays the instrument status includes the Not Ready messages.
	The HOME key opens Main Menu and comes back to the returns precedent page menu.
	The SCROLL UP and SCROLL DOWN arrow keys are used to scroll through a list of menus or to move the cursor to an editable field.
	The INC crease key allows increasing the parameter value.
	The DEC crease key allows decreasing the parameter value.
	The ENTER key confirms changes to a selected menu item

Parameters Entry

The user points to any of the parameter navigating with the keys **HOME**, **SCROLL UP** and **SCROLL DOWN**.

Only the bottom line is dedicated to parameters editing, first line is only for menu title and doesn't scroll. Once you have reached the line related to the parameter to change, increase or decrease the value by pushing the **INC** and **DEC** keys. During editing the value of the parameter is blinking.

OVEN	Menu Title Line
Temp 100 100	Parameter Editing Line

When the set value is the desired one, press the **ENTER** key, to accept the value.

Any key different from **ENTER**, **INC**, **DEC** will escape parameter editing without changes.

User Interface Main Menu

To open the main menu, press the **HOME** key. The Main menu contains the following page menus available sequentially by pressing the **SCROLL UP** and **SCROLL DOWN** arrow keys.

FOCUS GC OVEN INLET CARRIER DETECTOR SIGNAL AUTOSAMPLER SEQUENCE ¹ OTHERS
--

1. Line available only if an autosampler is present

To open a page menu move the cursor up to the menu of interest, then press **ENTER** key. To come back precedent page menu press the **HOME** key.

Oven

OVEN Temp 100 100

Use the Oven page to set temperatures, times and ramp rates. You can program up to four temperature ramps *per* run. Refer to Chapter 4 [Column Oven](#) for more information about Oven menu options.

Inlet

INLET	
Temp	200 200

Use this page to set inlet parameters such as temperature and split flow.

Refer to Chapter 5 *Split/Splitless Injector (S/SL)* or Chapter 6 *Purged Packed Column Injector (PPKD)* for more information about Inlet menu options.

Carrier

CARRIER	
Pressure	100 100

Use this page to display in the carrier menus vary with the pressure and flow modes you select.

You have a choice of two flow modes:

- Constant pressure mode, which sets pressure only
- Constant flow mode which maintains a specific flow rate through the column.

Refer to Chapter 3 *Gas Control* for more information about Carrier menu options.

Detector

Use this page to display the detector menu:

DETECTOR (FID)	
Flame	Off

DETECTOR (TCD)	
Filament power	Off

Refer to Chapter 8 *Flame Ionization Detector (FID)* or Chapter 9 *Thermal Conductivity Detector (TCD)* for more information about Detector menu options.

No Detector



ATTENTION!

If the detector is not present but the detector zone is enabled, the following page is displayed:

DETECTOR (MS)		
MS X-line	200	200

External Detector

In the case of external detector the following page will be displayed:

DETECTOR (FID-X)		
Temp	200	200

The name of the external detector in use, e.g. FID-X, is added in the title line.

Signal

Use this page to display the FID or TCD detector signal menu

SIGNAL (FID)	
Output	(1000000)

SIGNAL (TCD)	
Output	(1000000)

The first item displays a unitless digital representation of the detector output. The other items help make that output more measurable and meaningful.

Refer to Chapter 8 *Flame Ionization Detector (FID)* or Chapter 9 *Thermal Conductivity Detector (TCD)* for more information about Signal menu options.

External Detector

In case of external detector the following page will be displayed:

```
SIGNAL (FID-X)
Output      (1000000)
```

The name of the external detector in use, e.g. FID-X, is added to the title line.

Autosampler

```
AUTOSAMPLER
Sample Volume      1.0
```

Use this page to display the AS 2000 or AI/AS 3000 autosampler parameters. Refer to Chapter 10 [Autosamplers](#) for more information about autosampler menu options.



TriPlus and HS 2000 autosamplers are controlled only by all the Thermo Fisher Scientific Data Systems referring to the instructions reported in the relevant operating manuals.

Sequence

```
SEQUENCE
First sample      1
```

Use this page to display the parameters required to perform an automatic sequence of samples. This page is displayed only if an AS 2000 or AI/AS 3000 autosampler is present.

Refer to Chapter 10 [Autosamplers](#) for more information about sequence menu options.

Others

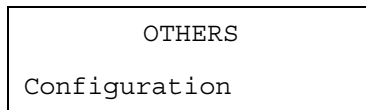

Use this page to entry the following submenu:

- *Time*
- *Valves*
- *Run Time Events*
- *Run-Log*
- *Configuration*
- *Info/Diagnostics*

Configuration

This paragraph describes how to configure your FOCUS GC.

When to Configure

You need to configure the system when:

- using the FOCUS GC for the first time
- changing carrier gas
- changing column types (to set the appropriate maximum oven temperature)
- connecting an external detector

For details refer to *Configuration Menu*.

Configuration Menu

In Main Menu press the **SCROLL DOWN** key until the **Others** page appears, then press **ENTER**.

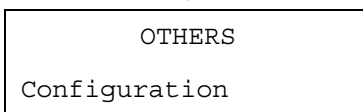

Scroll to **Configuration** and press **ENTER**. The following table describes the items in the **Configuration** menu.

Table 2-3. Configuration Menu

Menu	Description
CONFIGURATION	This line is the title bar.
Oven	Controls preliminary actions such as an automatic prep run, timeout, equilibration time.
Carrier	Controls the type of carrier gas.
Detector	Allow to select an external detector when the signal coming from an external control module is desired. This line is available ONLY if the FID board is present.
Autosampler	Controls the autosampler connected.
General	Visualizes the Main supply frequency.
Keyboard and Display	Controls keypad and display preferences.
Handshake	Configures the polarity of signals from external device.
Time	Sets the time and data.
Valves	Controls the eventual gas sampling valve (when available).

Oven Configuration Menu

The FOCUS GC oven provides great flexibility in controlling and programming temperatures. In the **CONFIGURE OVEN** menu you can set various preparatory parameters.

CONFIGURE OVEN	
Max temperature	300
Equilib. Time	10.00
Auto prep run	Off
Auto start	Off
Prep-run timeout	10

Table 2-4. Configure Oven Menu

Parameter	Range or Options	Comments
CONFIGURE OVEN		This line is the title bar.
Max temp	50–350 °C in steps of 1 °C	This parameter defines the maximum allowable oven temperature setpoint to protect the column from unintentionally high temperatures. This limit must be set to the manufacturer's maximum recommended operating temperature for the column.
Equil time	0.00–999.99 min	This parameter defines the equilibration time to stabilize the oven temperature after the run.
Auto prep run	On/Off	Set On to turn on automatic Prep Run execution without pressing START key. When this item is set to Off , you must to press START key activate the Prep Run .
Auto Start	On/Off	Provides an automatic <i>Start</i> command to GC.
Prep run timeout	0.00–99.00 min	Enter the duration of the Prep Run . The injection must occur within this time or the timeout will set the GC to Standby condition.

Carrier Configuration Menu

Commonly used gases are Helium, Hydrogen and Nitrogen. Hydrogen offers the best chromatography properties (optimum resolution at the highest flow rates). However, because Hydrogen is flammable, Helium is often used as an alternative for carrier gas.

You specify the type of carrier gas in the **CONFIGURE CARRIER** menu by using the **INC** and **DEC** key.

CONFIGURE CARRIER	
Gas Type	Helium

Table 2-5. Configure Carrier Menu

Parameter	Range	Comments
CONFIGURE CARRIER		This line is the title bar.
Gas type	Helium Nitrogen Hydrogen Argon	To select the required carrier gas. The default carrier gas is Helium (He).



WARNING! Hydrogen items is disabled unless your instrument has a hydrogen sensor. See [Using Hydrogen](#).

Detector Configuration Menu



CAUTION This line is available **ONLY** if the detector board is present and detected at GC power up.

An external detector is a detector controlled by an external control module. The FOCUS GC only provides the heating through the base body, the gas supply and the signal analog to digital conversion for acquisition.

You specify the type of external detector in the **CONFIGURE DETECTOR** menu by using the **INC** and **DEC** key.

```

CONFIG DETECTOR
Use external det?  Y
Ext det type      FID-x
                  ECD-x
                  NPD-x
                  FPD-x
                  PID-x
                  PDD-x
                  Hall-x
                  Other-x
  
```

The following list determine the type of gas to use with the different external detectors:

External Detector Type	Gas Available
FID-x	H ₂ , Air, Make-up
ECD-x	Make-up
NPD-x	H ₂ , Air, Make-up
FPD-x	H ₂ , Air, Make-up
PID-x	Make-up, Sheath gas (instead of air)
PDD-x	None

External Detector Type	Gas Available
Hall-x	H ₂ , Make-up
Other-x	H ₂ , Air, Make-up

Autosampler Configuration Menu

The autosampler method can be controlled from the FOCUS GC or the data system.



ATTENTION! Only with the AS 2000 the alignment must be programmed with control module.

You specify the information required in the **CONFIG AUTOSAMPLER** menu by using the **INC** and **DEC** key. According to the type of autosampler connected to the GC you may find the following menus:

AS 2000 Autosampler

```
CONFIG AUTOSAMPLER ↓
Status           Disabled
Use Internal Std Yes
```

Table 2-6. Configure AS 2000 Autosampler Menu

Parameter	Range	Description
CONFIG AUTOSAMPLER		This line is the title bar.
Status	Not Editable	It shows the status of the autosampler
Use Internal STD	Yes – Not	Specify the use of the internal standard option.

AI 3000/AS 3000

CONFIG AUTOSAMPLER ↓	CONFIG AUTOSAMPLER ↓
Syringe volume 10	Syringe volume 10
Sample tray 105	Sample tray 8

Table 2-7. Configure AI 3000/AS 3000 Autosampler Menu

Parameter	Range	Description
CONFIG AUTOSAMPLER		This line is the title bar.
Syringe volume	5 – 10 μ L	Select the parameter according to the volume of the syringe installed on the autosampler.
Sample tray	Not Editable	The system automatically recognizes the type of sample tray installed on the autosampler: - 105 positions tray in the case of AS 3000 Autosampler - 8 position tray in the case of AI 3000 Autoinjector.

Messages

When the autosampler is not present the following message is displayed:

<p>CONFIG AUTOSAMPLER</p> <p>Not present</p>
--

or if the GC is connected to the data system the following message is displayed:

<p>CONFIG AUTOSAMPLER</p> <p>Locked by Data System</p>
--

General Configuration Menu

Use this item to visualize the mains supply frequency.

GENERAL CONFIG	
AC mains freq.	50

Table 2-8. General Config Menu

Parameter	Range	Description
GENERAL CONFIG		This line is the title bar.
AC mains freq.	50 - 60	Mains frequency.

Keyboard & Display Configuration Menu

This menu allows you to customize your keyboard and display.

Keyboard beep leads to a submenu where you can specify when you want the GC to alert you with a keyboard sound. To move to the submenu, select **Keyboard beep** and press **ENTER**.

CONFIG KEYB. & DISP.	
Keyboard lock	Off
Keyb. Beep Enter key	
Delimiter type	“.”
Pressure unit	kPa
Brightness	3

Table 2-9. Configure Keyboard & Display Menu

Parameter	Range	Description
CONFIG KEYB. & DISP:		This line is the title bar.
Keyboard lock	On – Off	This parameter locks the keypad from editing.
Keyb. beep	Refer to Beep Table	This parameter causes the GC to beep when you press the key specified in the submenu.
Delimiter type	“.” or “,”	Use this option to select a period or comma as a decimal marker.
Pressure units	kPa – psi – bar	Use this option to select the pressure unit for display
Brightness	3 = max 0 = min	Use this option to adjust the brightness of the display.

Beep Table

Table 2-10. Beep Table

Parameter	Range	Description
KEYBOARD BEEP:		This line is the title bar.
All key	On -Off	This parameter causes the GC to beep when you press any key on keypad.
Enter key press	On -Off	This parameter causes the GC to beep when you press ENTER .
On invalid key	On -Off	This parameter causes the GC to beep when the key you press is not a valid option.
Never	On -Off	This option turns off keyboard beep.

Handshake Configuration Menu

The FOCUS GC can be coupled to other instruments, such as an autosampler or a mass spectrometer. To allow other devices to run properly, you must indicate how the signal will change. For example, the menu line specifies that another device will start the GC when the remote start signal changes from high to low.

CONFIG HANDSHAKE	
Remote start in	H L
Inhibit ready	High
End of run out	H L
Start of run out	H L
GC ready out	High
Prep run out	High

Table 2-11. Configure Handshake Menu

Parameter	Range	Description
CONFIG. HANDSHAKE		This line is the title bar.
Remote Start IN	Pulse High to Low (default) Pulse Low to High	This parameter allows another device to start the FOCUS GC.
Inhibit Ready	When Low (default) When High	This parameters delays readiness until the GC receives a signal from another device.
End of Run OUT	Pulse High to Low (default) Pulse Low to High	This parameter signals another device that the run has ended.
Start of RUN OUT	Pulse High to Low (default) Pulse Low to High	This parameter signals another device that the run has started.
GC Ready OUT	When Low (default) When High	This parameter signals another device that the GC is ready.
Prep-Run OUT	Pulse High to Low (default) Pulse Low to High	This parameter signals another device that the GC is preparing for a run.

Time Configuration Menu

FOCUS GC displays the current date and time. You can set this time from the **CONFIGURE** menu. When you open the **CONFIGURE TIME** menu, the following items appear:

```

CONFIGURE TIME
Time:          18:14:11
Date: Mon 11/Mar/2002
    
```



NOTE

Time is set on a 24-hour clock.

Table 2-12. Configure Time Menu

Parameter	Range	Description
CONFIGURE TIME		This line is the title bar.
Time:	hhmm	This option has two editing fields sequenced by pressing ENTER .
Date:	Day Month Year	This option has three editing fields sequenced by pressing ENTER

Valves Configuration Menu

You can configure two gas sampling valves, when present, and program two external events to be the default condition for an external device. See also [Run Time Events](#)

```

CONFIGURE VALVES
Valve#1 Gas sampling
Valve#2          none
EV#1 default    Off
    
```

Table 2-13. Configure Valves Menu

Parameter	Range	Description
CONFIGURE VALVES		This line is the title bar.
Valve #1	None Gas Sampling	Select in this box Sampling only if a gas sampling valve is present and connected the GC. Otherwise, select none.
Valve #2	The same as Valve # 1	
EV #1 default	On - Off	Select the external event device default Condition. The external device will return to the condition specified by the external event you have programmed to be the default whenever the GC is in Standby mode.
EV #2 default	The same as EV #1	

Run Time Events

This options allows you to program events to happen before to or during a run. For instance, a valve could open two minute into a run.

You can program:

- An output signal adjustment, such as autozero.
- A valve to open or close.
- An external event from another device.

In Main Menu move the cursor until **Others** page is selected, then press **ENTER**. Scroll to Run time event then press **ENTER**.

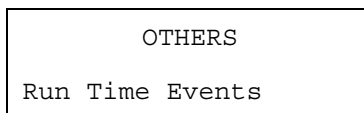

The first time you program a time event (Run Time Events empty) the following menu appears:

```

RUN TIME EVENTS
<None>
Add run time event

```

Option	Description
<none>	No events are programmed
Add run time event	Scroll to this line end press ENTER to add an event

In **RUN TIME EVENTS** menu scroll to Add run time events and press **ENTER**:
The following menu appears:

```

EDIT EVENTS
Event                EV#1
Run time            Pre run
Setpoint                2
Next event

```

Table 2-14. Edit Time Event Menu

Parameter	Range	Description
EDIT TIME EVENTS		This line is the title bar.
Event	Det autozero – Det range – Det gain ⁽¹⁾ – Det neg pol ⁽¹⁾ – EV#1 – EV#2 GSValve#1 - GSValve#2	Select the event you want to program.
Run time	0.00 to 599.99 minutes Prep run	Select a time if you want to activate the event during the Run Time. Select Prep run if you want to activate the event at the Prep run.

Table 2-14. Edit Time Event Menu (Continued)

Parameter	Range	Description
Setpoint	From 0 to 3 for Det range On/Off for EV	Select the correct setpoint according to the event you have set in the previous line. This line doesn't appear for Det autozero.
Next event	---	Add a new event

1. Parameters available only with the TCD detector

To program a **Run Time Event**, refer to Chapter 11 *Getting Started*.

Run-Log

This function displays the run log, which records errors or method changes that happen in run time. It display the time and describes any deviation that occur. This information is used to meet good laboratory practice (GLP) standards. For example, if you interrupt the run for any reason, the run log will record the time the run stopped and a description of the event. The Run-log is cleared and reset at the beginning of the next run.

Run log entries are shown pressing the **STATUS** key.

To see the details Run-Log entries, in Main Menu move the cursor until the **Others** page is selected, then press **ENTER**. Scroll to Run-log then press **ENTER**

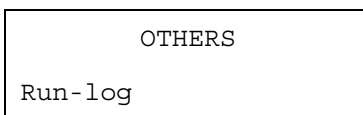

An example of Run-log is shown below.

<p style="text-align: center;">RUN LOG (XofY)</p> <p>Itime 200.00 ' 220.00 at run time 0.50</p> <p>ITemp 120 ' 100 at run time 2.00</p> <p>Ftime 1.00 ' 10.00 at run time 2.50</p> <p>Ramp2 50.0 ' 120.0 at run time 3.10</p> <p>Flame out at run time 3.50</p> <p>Flame retry failed at run time 3.30</p> <p>Oven T is 105 (110) at run time 3.40</p> <p style="text-align: center;">↓</p> <p style="text-align: center;">(continue)</p> <p style="text-align: center;">with FID</p>	1 2 3	<p style="text-align: center;">RUN LOG (XofY)</p> <p>Itime 200.00 ' 220.00 at run time 0.50</p> <p>ITemp 120 ' 100 at run time 2.00</p> <p>Ftime 1.00 ' 10.00 at run time 2.50</p> <p>Ramp2 50.0 ' 120.0 at run time 3.10</p> <p>Detector gain 1 ' 10 at run time 3.50</p> <p>Detector neg pol Y'N at run time 3.30</p> <p>Oven T is 105 (110) at run time 3.40</p> <p style="text-align: center;">↓</p> <p style="text-align: center;">(continue)</p> <p style="text-align: center;">with TCD</p>	1 2 3
--	---	---	---

Line	Description
1	The number of entry X of Y = e.g. 1 of 12, is displayed in the title line
2	The initial time has been changed from 200 to 220
3	The actual oven temperature is 105 instead of 110 as setpoint value

Time

This option allows you to visualize the following parameter

- Time
- Date
- Last run time
- Next run time
- Elapsed time and time remaining during the current run
- The flow calculator

In Main Menu move the cursor until the **Others** page is selected, then press **ENTER**. Scroll to **Time** then press **ENTER**

OTHERS
Time

When the GC is not running a menu appears as follows:

TIME	
Next runtime	15.00
Last runtime	120.00
We 13 Mar 2002	12:03
V=100 F=100.0	01:00
Flowmeter volume	100

When the GC is running a menu appears as follows:

TIME	
Elapsed time	5.00
Time left	110.00
We 13 Mar 2002	12:03
V=100 F=100.0	01:00
Measured volume	100

Valves

Use this feature to specify and control up to four valves, or to manually change the state of inlet valves. For example you can manually:

- Open or close the S/SL inlet valves before or during a run
- Switch a gas sampling valve from load to inject position
- Activate or deactivate an external event

In the Main Menu move the cursor until the **Others** page is selected, then press **ENTER**. Scroll to `Valves` then press **ENTER**

OTHERS	
Valves	

When a gas sampling valve is not present a menu appears as follows:

VALVES	
Split valve	Off
Sept purge valve	On
EV#1	Off
EV#2	Off

When a gas sampling valve is present and configured (refer to *Valves Configuration Menu* in paragraph *Configuration*) a menu appears it follows:

VALVES	
Split valve	Off
Sept purge valve	On
GSValve#1	Load
EV#1	Off

Table 2-15. Valves

Parameter	Range	Description
VALVES		This line is the title bar.
Split valve	On - Off	Switches On/Off the SSL split valve
Sept purge valve	On - Off	Switches On/Off the SSL septum purge valve
EV#1 - EV#2	On - Off	Switches On/Off the external valves
GSValve#1 GSValve#2	Load - Inject	Switches Load/Inject the gas sampling valve

To manually control valves, refer to Chapter 11 *Getting Started*

Info/Diagnostics

Use this feature to bring up hardware, software and diagnostic information

In Main Menu move the cursor until the **Others** page is selected, then press **ENTER**. Scroll to *Info/Diagnostics* then press **ENTER**

OTHERS	
Info/Diagnostics	

A menu appears as follows:

INFO/DIAGNOSTICS	
Serial #:	12345678
FW ver:	2.00.31
DPFC ver:	0.27
BOOT ver:	1 B.0
Manufact.:	1/Jan/02
Total runs	1234567
Ambient press	103.0

Table 2-16. Info/Diagnostics

Parameter	Description
INFO/DIAGNOSTICS	This line is the title bar.
Serial # T	The number (eight figures) indicates the product code.
FM ver:	Indicates the version of the firmware.
DPFC ver:	Indicates the version of the DPFC module.
BOOT ver:	Data for Thermo Fisher Scientific authorized technical personnel only.
Manufact.:	Indicates the manufacturing date of your GC.
Total runs	The number (seven figures) Indicates the performed analyses.
Ambient press	Indicates the ambient pressure expressed in kPa.

Gas Control

This chapter contains information on controlling and programming the carrier and detector gas flows to the FOCUS GC.

Chapter at a Glance...

Gas Supplies	72
Carrier Gas Regulation	75
Detector Gas Regulation.....	75
Measuring Gas Flow.....	78
Carrier Gas Parameters.....	80

Operating Sequences

Configuring the Carrier Gas	73
Configuring The Pressure Unit.....	74
Measuring the Detector Gas Flows with a Bubble Meter	78

Gas Supplies

The commonly used gases are helium, hydrogen, nitrogen and air. Hydrogen offers the best chromatography properties (optimum resolution at the highest flow rates). However, because hydrogen is flammable, helium is often used as an alternative for carrier gas. You can specify the type of gas and pressure units the FOCUS GC displays.

The TCD detector requires the same gas whether for the measure channel (carrier and make-up gas, when necessary) and the reference channel (reference gas). Helium is the recommended carrier gas due to its high thermal conductivity and chemical inertness.

- The default carrier gas is Helium (He)
- The default pressure unit is the kilo pascal (kPa).



WARNING! Hydrogen is a dangerous gas that, when mixed with air, may create an explosive mixture. The use of hydrogen as a carrier gas requires the operator's extreme caution. Special precautions must be taken because of the risk of explosion. The gas chromatograph must be equipped with a hydrogen sensor if you use hydrogen as a carrier gas. Refer to [Using Hydrogen](#) for more information. All Thermo Fisher Scientific gas chromatographs are designed to use an inert gas as the carrier gas. If you wish to use hydrogen as a carrier gas, you must install a hydrogen sensor. Contact a Thermo Fisher Scientific sales representative if you plan to use hydrogen as the carrier gas in FOCUS GC. If you don't have the hydrogen sensor, you must use an inert carrier gas.

You specify the pressure units and the type of carrier gas in **Configuration** menu operating as described in the following *Operating Sequences*

OPERATING SEQUENCE

Configuring the Carrier Gas

Carrier gas is already configured to Helium. To change the configuration, proceed as follows:

1. In the Main Menu move the cursor until **Others** is selected, then press **ENTER**.
2. Scroll to **Configuration** then press **ENTER**.
3. Scroll to **Carrier**, then press **ENTER**.

CONFIGURE CARRIER	
Gas type	Helium

4. Select the required type of carrier gas by using **INC** and **DEC** keys.
5. Press **HOME** to exit.

OPERATING SEQUENCE

Configuring The Pressure Unit

The pressure Unit is already configured to kPa (kilo pascal). To change the configuration proceed as follows:

1. In the Main Menu move the cursor until **Others** is selected, then press **ENTER**.
2. Scroll to **Configuration** then press **ENTER**.
3. Scroll to **Keyboard & Display**, then press **ENTER**.
4. Scroll to **Keyboard & Display**, then press **ENTER**.

CONFIG KEYB. & DISP.	
Pressure unit	kPa

5. Select the required type of carrier gas by using **INC** and **DEC** keys.
6. Press **HOME** to exit.

Carrier Gas Regulation

This paragraph describes the automatic Digital Pressure and Flow Control (DPFC) of the FOCUS GC. You control the gas flow by programming parameters in the carrier gas menu.

The DPFC module, provides:

- Flow and pressure control
- Gas saver function

You enter the gas control setpoints in the **Carrier** menu. Refer to [Carrier Gas Parameters](#).



WARNING! Input pressure to DPFC should ensure a minimum pressure 50 kPa higher than the maximum carrier pressure required by the application. The maximum input pressure to DPFC is 1000 kPa.

Detector Gas Regulation

The detector gases control module has conventional pneumatic regulators which and provides control for the detector gases.



WARNING! Pressure of the supply gas lines should be set to a minimum of 400 kPa (60 psi) to ensure the regulation of detector gases.

Maximum input pressure to FOCUS GC (from supply gas lines) is 1000 kPa (145 psi).

The pressure regulation is accessible from outside the instrument. The adjustment of the detector gases is done in factory prior shipment.

According to the detector in use refer to:

- [FID Gases](#)
- [TCD Gases](#)

FID Gases

The FID requires hydrogen and air as fuel gas and nitrogen as make-up gas. The adjustment of the detector gases flow is done in factory prior shipment.

Gas	Flow
Hydrogen (fuel gas)	35 mL/min
Air (fuel gas)	350 mL/min
Nitrogen (make-up gas)	30 mL/min

Verify that the corresponding gases flows are correct. If not, adjust the value turning the relevant regulation screw as shown in Figure 3-1.

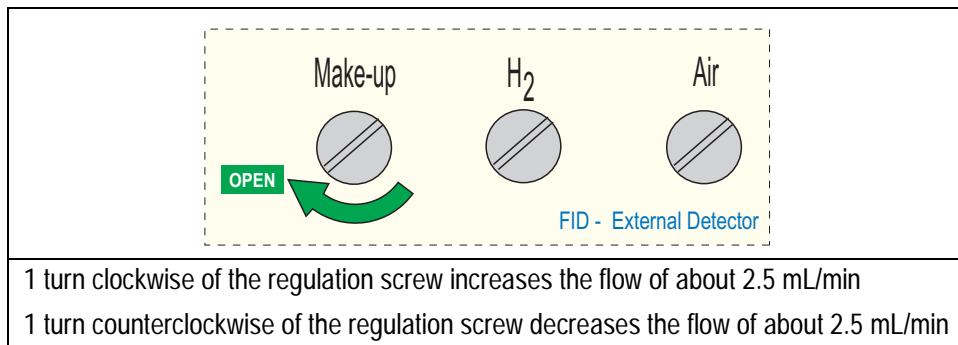

Figure 3-1. FID-External Detector Gases Flow Regulation.

The flow is measured at the exit of the detector base body. Enter the FID detector control menu to turn the flow on/off.

TCD Gases

The TCD detector requires the same gas whether for the measure channel (carrier and make-up gas, when necessary) and the reference channel (reference gas) Helium is the recommended carrier gas due to its high thermal conductivity and chemical inertness.

The adjustment of the detector gases flow is done in factory prior shipment.

Gas	Flow
Helium (make-up gas)	27 mL/min
Helium (reference gas)	30 mL/min

Verify that the corresponding gases flows are correct. If not adjust the value turning the relevant regulation screw as shown in Figure 3-2.

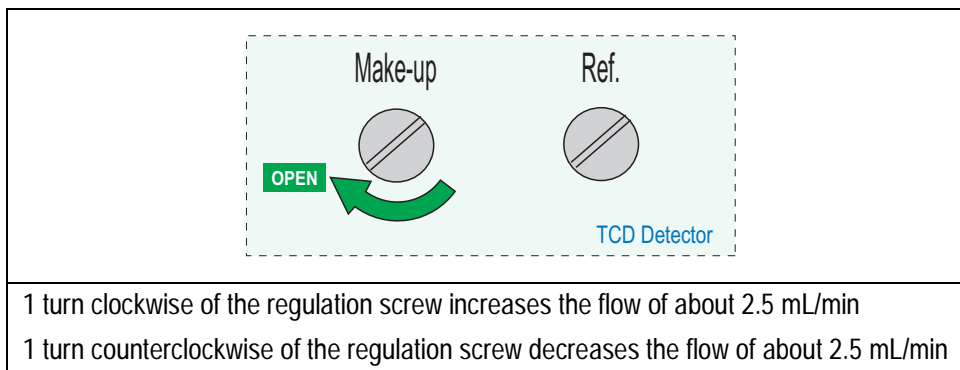

Figure 3-2. TCD Detector Gases Flow Regulation

The flow is measured at the exit of the detector. Enter the TCD detector control menu to turn the flow on/off.

Measuring Gas Flow

The septum purge and split flows can be measured at the relevant vents located on the top of the instrument. Detector gas flows can be measured at the detector vent. Use a bubble flow meter or a calibrated electronic flow meter to check flows. A built-in flow calculator, accessible by the GC keypad, helps you measure the flow when you use a bubble flow meter.

OPERATING SEQUENCE

Measuring the Detector Gas Flows with a Bubble Meter

Materials required:

- Graduated bubble flowmeter (the bulb must be half-filled with a soap solution)
- Detector base body adapter (for FID only)



WARNING! Do not measure hydrogen together with air or oxygen. This can create an explosive mixture. Always measure the gases separately.

1. Attach the inlet line of the flowmeter to the exit of the detector base body using the adapter.
2. While holding the bubble flowmeter vertically, squeeze and release the bulb to produce a meniscus in the bubble meter.
3. In Main Menu, move the cursor until **Others** is selected, then press **ENTER**.
4. Scroll to **Time** then press **ENTER**.

```
TIME
V=100 F=100.0 01:00
Flowmeter volume 100
```

5. Scroll to **Measured vol.** and set the volume that you wish to measure.

6. Scroll to the stopwatch line (F= 000 00:00).
7. When the meniscus passes the flowmeter start line, marked 0, press **ENTER** to start the stopwatch.
8. When the meniscus passes the flowmeter line corresponding to the volume set in Measured vol, press **ENTER** to stop the stopwatch. The flow rate in mL/min is automatically calculated and the value is displayed.

Carrier Gas Parameters

This paragraph explains the electronic programming and control of the GC carrier gases. The Digital Pressure Flow Control (DPFC) module regulates carrier gas electronically. You control the gas flow by programming parameters in the carrier gas menu.

The **CARRIER** menu includes the control parameters for the carrier gas, regardless of the carrier gas type. Parameters change according to the selected flow mode: constant flow or constant pressure.

In Main Menu, move the cursor until **carrier** is selected. Press **ENTER** to open the **CARRIER** menu.

```
CARRIER
Flow mode  Const flow
```

Flow Mode

Two flow modes are available.

Constant Flow

In constant flow mode, the column flow is kept constant throughout the analysis. The pressure at the column head will change with the column temperature to maintain the set flow.

Constant Pressure

In constant pressure mode, the pressure at the column head is kept constant throughout the analysis. Flow rate will decrease as oven temperature increases.

CARRIER (He)	CARRIER (He)
Pressure (100)	Pressure 100 100
Col.Flow 12.0 12.0	Col.Flow (10.0)
Flow mode Const flow	Flow mode Const Pres
Gas saver flow 100	Gas saver flow 100
Saver time 1.00	Saver time 1.00
Vacuum comp. Off	Vacuum comp. Off
Leak check	Leak check
Column evaluation	Column Evaluation
Carrier Menu in Constant Flow Mode	Carrier Menu in Constant Pressure Mode

Table 3-1. Carrier Gas Parameters Menu

Parameter	Range	Description
CARRIER (He)		This line is the title bar.
Col.Flow	From 0.1 to 50.0 ml/min in steps of 0.1 ml/min; Off	It is displayed when Constant Flow is selected in Flow Mode . Enter a column flow for the analytical column.
Pressure	From 10 to 1000 kPa (from 2.5 to 250 kPa) in step of 1 kPa; Off	It is displayed when Constant Pressure is selected in Flow Mode . Enter inlet pressure for the analytical run.
Flow Mode	Constant Flow; Constant Pressure	Set the operating mode required. Selecting Constant Flow , the column flow is kept constant throughout the analysis. The pressure at the column head will change with the column temperature to maintain a consistent flow. Selecting Constant Pressure , the pressure at the column head is kept constant throughout the analysis. During a temperature program, the column flow decrease due to the increase of the carrier gas viscosity.

Table 3-1. Carrier Gas Parameters Menu

Parameter	Range	Description
Gas Saver Flow	From 10 to 500 ml/min in step of 1 ml/min; Off	Activates gas saver control to reduces carrier gas consumption after the injection or in Standby (suggested at high split mode).
Gas Saver Time	From 0 to 9.99 minutes in steps of 0.01 min	Enter the time after the injection when gas saver flow will be activated.
Vacuum Compensation	On - Off	Use this option to compensate for a vacuum at the end of the analytical column. When the box is not checked calculation are made considering the detector outlet at atmospheric pressure.
Leak check	It allows performing an automatic leak check. The GC starts to measure the column flow with a true mass flow sensor and compares it to the calculated flow from the original column constant to see if the numbers match. The instrument assumes a gas leak exists if there is a significant difference. To perform a leak check refers to Chapter 6 <i>Performing an Automatic Leak Check</i> .	
Column evaluation	The <i>column evaluation</i> is an automatic measurement of the column resistance that determines the <i>column constant</i> . To perform the column evaluation, the system uses the correlation between the applied pressure to the flow and the column temperatures. This operation must be carried out every time a new column is installed. Before performing the column evaluation, a <i>manual</i> leak test of the system must be carried out. To perform a column evaluation refer to Chapter 6 <i>Performing a Column Evaluation</i> .	

4

Column Oven

This chapter describes the features of the FOCUS GC column oven.

Chapter at a Glance...

Column Oven Overview	84
Column Oven Configuration	86
Oven Parameters.....	87

Operating Procedures

Configuring the Column Oven	86
Setting Up a Single Ramp Temperature Program	89
Setting Up Multiple Ramp Temperature Program.....	90

Column Oven Overview

The FOCUS GC column oven, shown in Figure 4-1, provides a stable heating environment for the analytical column. The oven heats and cools quickly. Efficient air circulation ensures a high degree of thermal stability.

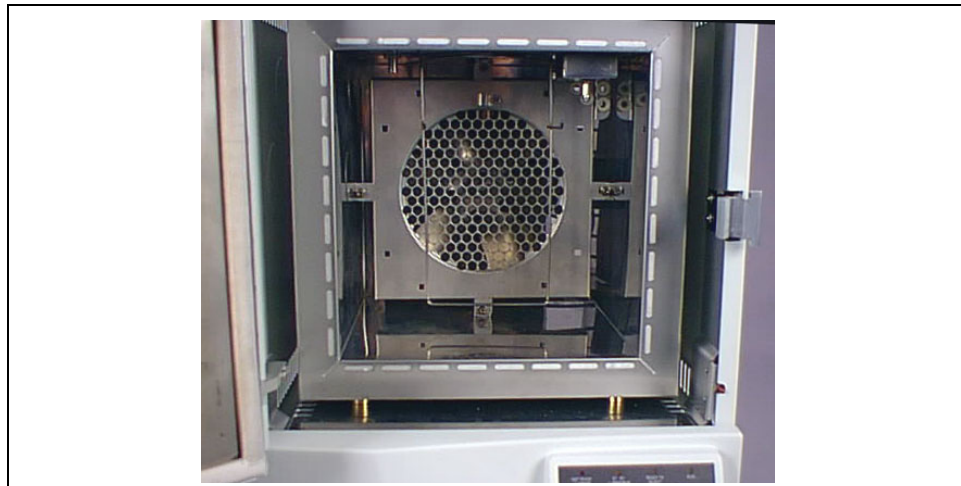

Figure 4-1. The FOCUS GC Column Oven

Opening the oven door activates a safety microswitch, which automatically turns off the oven heating and the fan motor.

The column oven has the following capabilities:

- maximum temperature of 350 °C
- maximum temperature increase rate of 120 °C/min
- seven linear temperature ramps and eight levels
- minimum operating temperature of a few degrees above ambient, which is obtained by two modulated cooling flaps controlled by the GC.

Oven Safety

Opening the oven door cuts off the power to the oven heater and fan. The setpoints are kept in memory. The display shows the following safety message:

OVEN
Temp 100 door open

To return to normal operation, close the oven door.



WARNING! The oven vents at the rear of the GC discharge hot air during cooling.



WARNING! Hydrogen is a potentially dangerous gas. When hydrogen is used as a carrier gas, the column oven must have a hydrogen sensor. Refer to Using Hydrogen for hydrogen safety information.

Column Oven Configuration

The **CONFIGURE OVEN** menu contains the control parameters for the column oven.

Refer to *Oven Configuration Menu* in Chapter 2 for more information about the **CONFIGURE OVEN** menu.

CONFIGURE OVEN	
Max temperature	300
Equilib. Time	10.00
Auto prep run	Off
Auto start	Off
Prep-run timeout	10

OPERATING SEQUENCE

Configuring the Column Oven

Use this sequence to configure the column oven. Use **INC** and **DEC** keys to increase or decrease the parameter values and confirm pressing **ENTER**.

1. In Main Menu, move the cursor until **others** is selected. Scroll to **Configuration** then press **ENTER**.
2. Scroll to **Oven**, then press **ENTER**.
3. Scroll to **Max temperature** and set the maximum allowable oven temperature
4. Scroll to **Equilibrium time** and set the oven temperature equilibration time.
5. Scroll to **Auto prep run**. Set **On** to enable automatic prep run. Set **Off** if you want the prep run to be activated by pressing the **START** key.
6. Scroll to **Prep Run timeout** and set the duration of the prep run timeout.

Oven Parameters

The **OVEN** menu contains the parameters for programming the oven temperature, from an initial temperature to a final temperature, using up to three ramps during the analytical run. It is possible to set a single (isothermal) or multiple ramp program.

In Main Menu move the cursor until **Oven** is selected. Press **ENTER** to display the **OVEN** menu.

OVEN	
Temp	100 100
Initial time	90.00
Ramp 1	120.0
Final temp 1	100
Final time 1	60.00
Ramp 2	Off

Table 4-1. Oven Parameters Menu

Parameter	Range	Description
OVEN		This line is the title bar
Temperature	On - Off From 20 °C to 350 °C in step of 1°C	Set On to display the actual and set point values. Set the initial temperature in °C at which the oven is set and conditioned before the GC enters the sampling phase.
Initial Time	INF From 0 to 99.99 minutes	Set the time in minutes. The oven remains at the starting temperature after a programmed run has begun. Setting INF, will cause the following menu lines to disappear.
Ramp 1	On – Off – INF From 0.1 to 120 °C/min in step of 0.1 °C/min	Rate for the temperature ramp from Initial Temp to Final temp 1. Set the rate increment to reach the temperature set in Final temp 1. Set On to enable a temperature ramp. Setting INF, the GC performs a ballistic heating and the ramp duration is zero.

Table 4-1. Oven Parameters Menu (Continued)

Parameter	Range	Description
Final temp 1	From 30 to 350 °C In step of 1 °C	This parameter defines the temperature the column oven will reach at the end of the heating or cooling ramp. This line only appears if Ramp 1 is On.
Final time 1	From 0 to 99.99 minutes	This parameter defines how long (in minutes) the oven will maintain the final temperature of the ramp.
Ramp 3-7	On - Off From 0.1 to 120 °C/min in step of 0.1 °C/min	After you program the first ramp, the menu adds the Ramp 2 parameter lines. If you do not want an additional ramp, leave this parameter set to Off. To program the ramp, set On. The Final temp and Final time lines for the ramp will be added to the menu. You can repeat this process to program up to seven temperature ramps.
Final temp 2-7	From 20 to 350 °C in step of 1 °C	This parameter defines the temperature the column oven will reach at the end of the relevant ramp.
Final Time 2-7	From 0 to 99.99 minutes	This parameter defines how long (in minutes) the oven will maintain the final temperature of the ramp.

OPERATING SEQUENCE

Setting Up a Single Ramp Temperature Program

This program raises the initial oven temperature to a specified final temperature at a specified rate and maintains the final temperature for a specified time.

Use **INC** and **DEC** keys to increase or decrease the parameter values and confirm pressing **ENTER**.

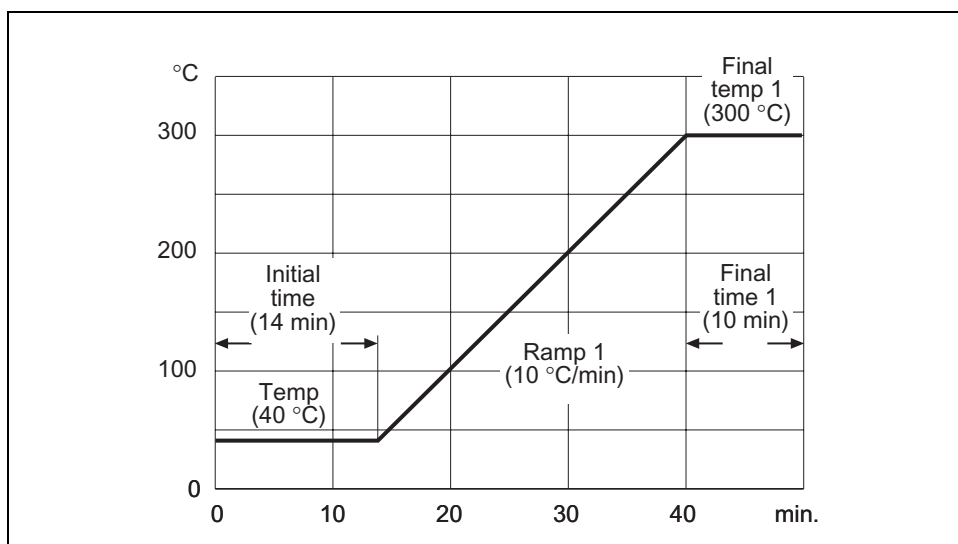

Figure 4-2. Example of Single Ramp Temperature Program

1. In Main Menu move the cursor until **Oven** is selected. Press **ENTER** to display the **OVEN** menu.
2. Scroll to **Temp** and enter the initial the initial temperature.
3. Scroll to **Initial Time** and enter the time you want the oven to maintain the initial temperature.
4. Scroll to **Ramp 1** and set it **On**. Enter the ramp rate in °C/min for the oven to reach the ramp's Final Temp.

5. Scroll to **Final Temp 1** and enter the final temperature for the ramp.
6. Scroll to **Final Time 1** and enter the time the oven will maintain the **Final temp.**
7. To end the single ramp program, **Ramp 2** must be **Off**.

OPERATING SEQUENCE

Setting Up Multiple Ramp Temperature Program

This program raises the initial oven temperature to a specified final temperature through up to three ramps, each having a specified ramp rate, time, and temperature.

Use **INC** and **DEC** keys to increase or decrease the parameter values. and confirm pressing **ENTER**.

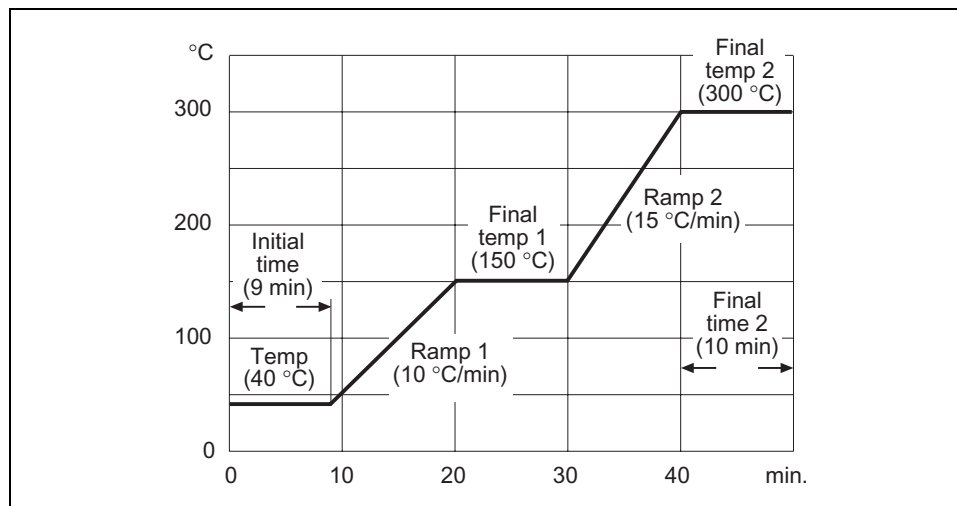

Figure 4-3. Example of Multiple Ramp Temperature Program

1. In Main Menu move the cursor until **oven** is selected. Press **ENTER** to display the **OVEN** menu.
2. Scroll to **Temp** and enter the initial the initial temperature.

3. Scroll to `Initial Time` and enter the time you want the oven to maintain the initial temperature.
4. Scroll to `Ramp 1` and set it `On`. Enter the ramp rate in $^{\circ}\text{C}/\text{min}$ for the oven to reach the ramp's `Final Temp`.
5. Scroll to `Final Temp 1` and enter the final temperature for the ramp.
6. Scroll to `Final Time 1` and enter the time the oven will maintain the `Final temp`.
7. Scroll to `Ramp 2` and set it `On`. Enter the ramp rate in $^{\circ}\text{C}/\text{min}$ for the second temperature program.
8. Scroll to `Final Temp 2` and enter the final temperature for the second ramp.
9. Scroll to `Final Time 2` and enter the time the oven will maintain the `Final temp`.
10. To end the multiple ramp temperature program, leave `Ramp 3` set to `Off`. To add additional oven ramp, repeat the step 7 through 9.

Split/Splitless Injector (S/SL)

This chapter describes the Split/Splitless (S/SL) injector and contains operating sequences for the different split/splitless operating modes.

Chapter at a Glance...

S/SL Overview	94
S/SL Injection Techniques.....	101
S/SL Inlet Parameters	107

Operating Sequences

Installing a Liner and a Septum.....	99
Programming the Split Mode	110
Programming the Splitless Mode	111
Programming the Surge Splitless Mode	112

S/SL Overview

The S/SL injector, shown in Figure 5-1, is optimized for either *split* or *splitless* applications to ensure effective sample transfer into the column, minimizing heavy component discrimination.

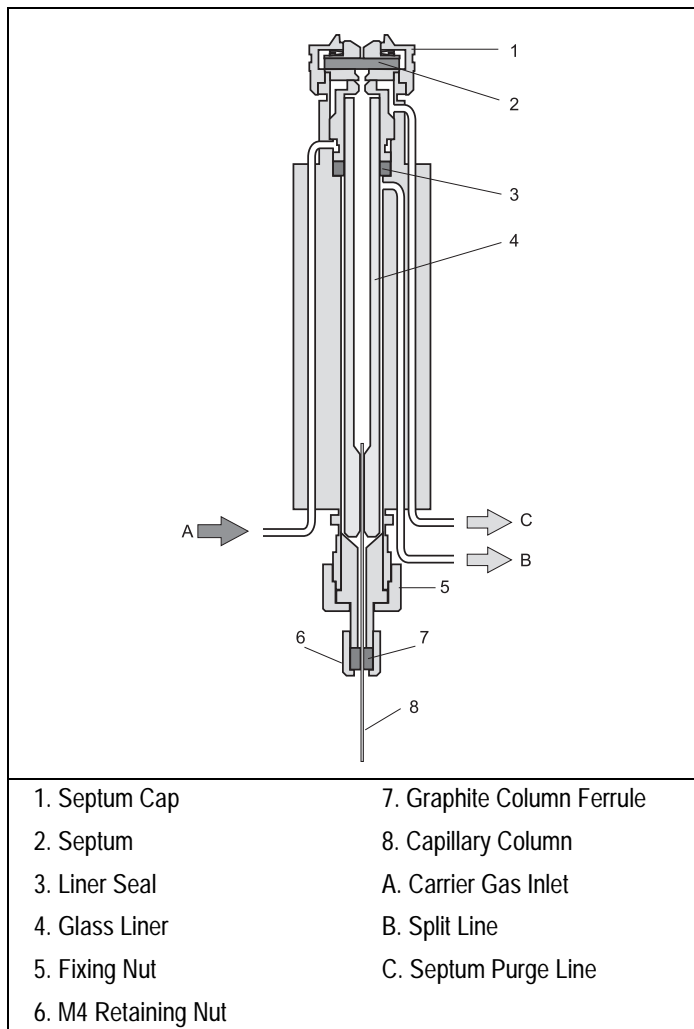

Figure 5-1. Split/Splitless Injector

For both split and splitless applications, the sample is injected through a septum into a glass liner in the vaporization chamber.

The technique used, either split or splitless, determines the choice of the glass liner and the length of the syringe needle. You can control the injector temperature from ambient to 375 °C, although the actual injector temperature you use depends on the solvent choice and thermal stability of the samples.

The Digital Pressure Flow Control (DPFC) controls the split flow, while the septum purge flow is kept constant by a calibrated flow regulator.

The S/SL injector is also equipped with electronically actuated On/Off valves for split and septum purge lines.

Volatile components given off by the hot septum can produce ghost peaks in a chromatogram. The septum purge system can continually purge the septum with a flow of gas. This prevents the volatile components given off by the septum from entering the column. Figure 5-2 shows the septum purge system.

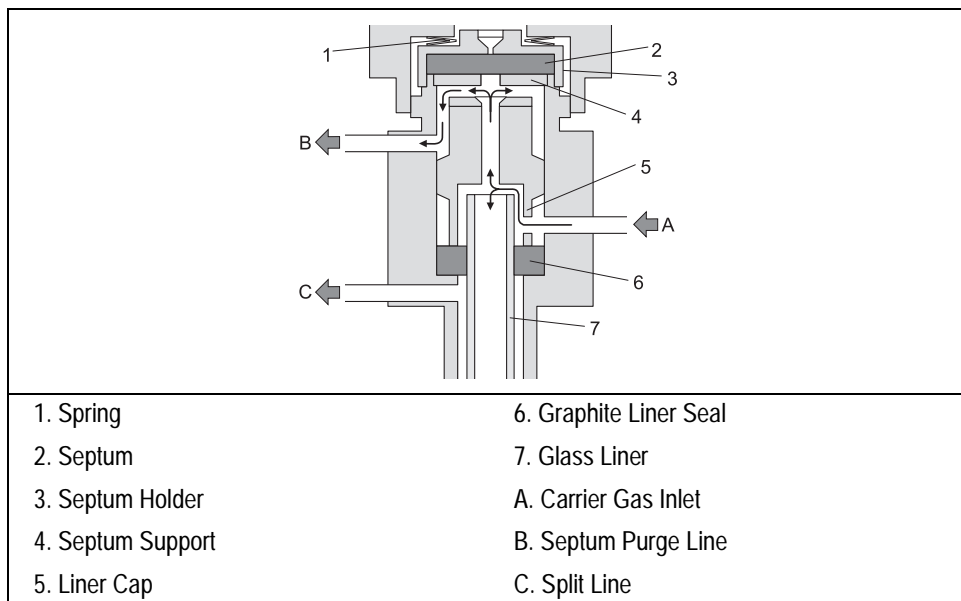

Figure 5-2. Septum Purge System

Figure 5-3 shows the S/SL injector components.

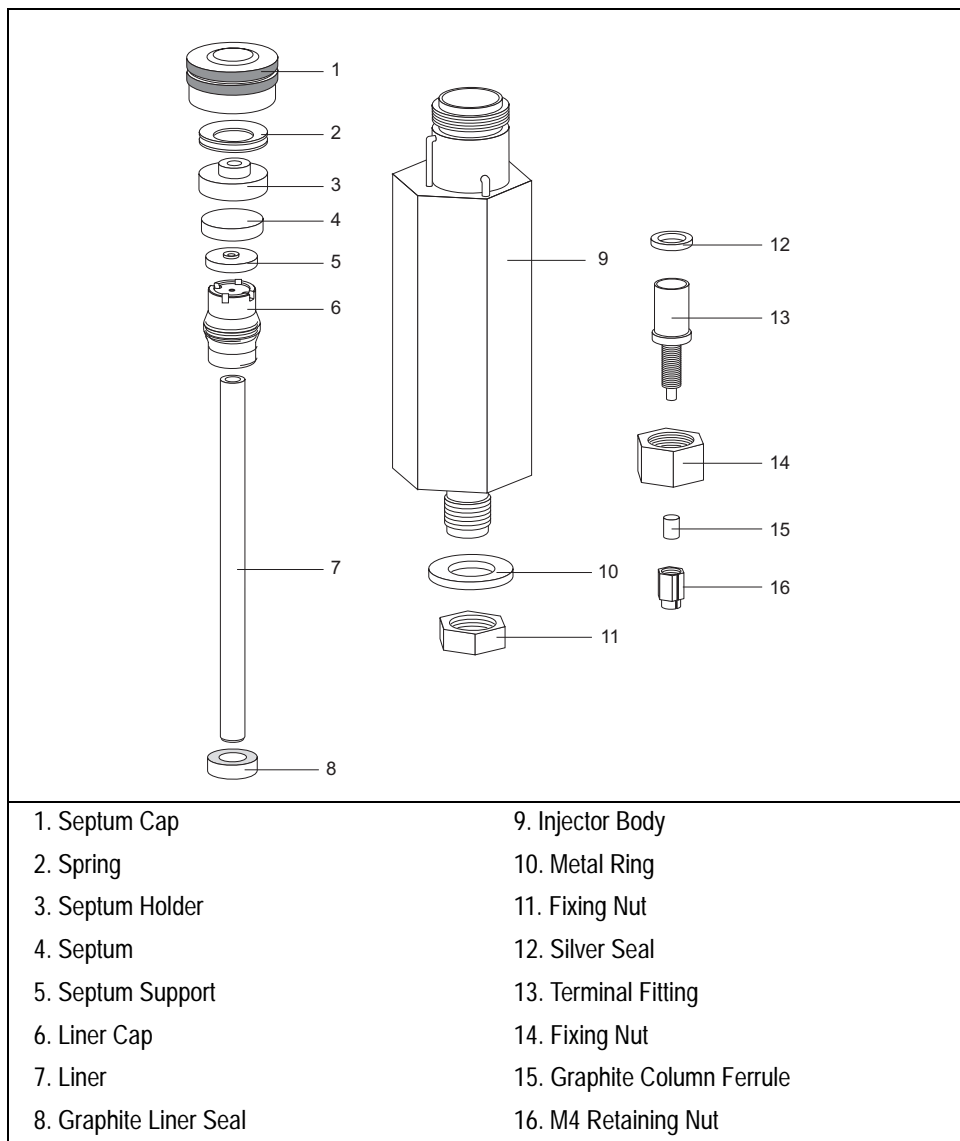

Figure 5-3. Split/Splitless Injector Components

Septum

Standard Septum

You should always use good quality septa, such as the BTO septa supplied with the FOCUS GC. Such septa resist deformation, have longer life expectancy, and have a low bleed level, even at high temperatures.

Microseal™ Valve

S/SL injector is compatible to use Merlin Microseal™ High Pressure Valve instead of the standard septa.



NOTE

To install the Microseal™ Valve, the relevant installation kit is required.

High pressure capability allows operation from 15 to 700 kPa (2-100 psi). Longer life reduces the changes of septum leaks occurring during extended automated runs. Microseal™ valve requires a 0.63 mm diameter (0.025-inch) blunt tip syringe.

Liners

You may choose among different types of glass liners depending on the injection mode used. Table 5-1 shows the liner options.

Table 5-1. Liner Sizes and Applications

ID mm	OD mm	Application
5	8	split injection
3	8	split injection
3	8	splitless injection
5	8	splitless injection
5	8	direct injection into a wide-bore column
5	8	split injection at high flow rates or for very polar solvents

Packed Columns

With a special adapting kit, you can install packed columns in the S/SL injector, as shown in Figure 5-4.

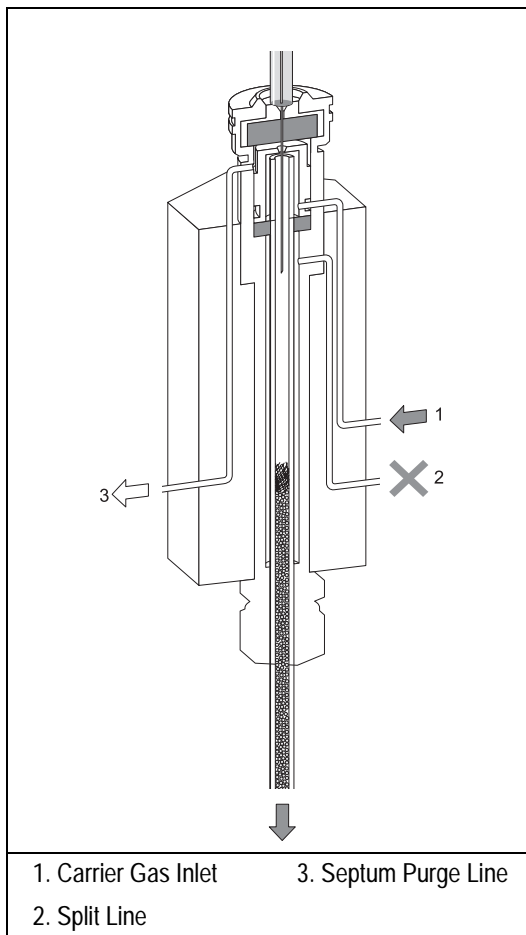

Figure 5-4. S/SL with a Packed Column

OPERATING SEQUENCE

Installing a Liner and a Septum

Materials required:

- liner
- septum
- tweezers
- graphite seal
- liner cap wrench (included with the GC)



NOTE

The injector fittings may be hot.

This sequence must be performed with the injector at working temperature.

1. Choose the correct liner for your application (see Table 5-1). Slide a graphite seal onto the liner from the bottom (the bevelled end) and push it to approximately 8–10 mm from top (the flat end).



CAUTION

Be careful not to break the graphite or to allow graphite to enter the liner.

2. Hold the top of the liner with tweezers. Lower it, bevelled end first, into the injector. The liner should rest on the terminal fitting at the bottom of the injector.
3. Hold the top of the liner with tweezers. Lower it, bevelled end first, into the injector. The liner should rest on the terminal fitting at the bottom of the injector.
4. Insert the liner cap and secure it with the liner cap wrench. The liner cap must be screwed down tight enough to ensure a good seal between the liner and the injector body.
5. Place the septum support in the injector. The septum support must lie flush with the top of the injector. If not, the liner cap may not be tight enough.

6. Use tweezers to pick up the septum. Place the septum into the septum holder, then place the holder on top of the complete injector assembly.



CAUTION To avoid contamination, do not touch the septum with your hands.

7. Gently screw the septum cap onto the injector assembly until finger-tight to hold the septum in place.



WARNING! If the injector is hot, use the liner cap wrench to turn the septum cap. Do not overtighten the septum cap. The septum will deform and may be difficult to penetrate with the syringe needle.

S/SL Injection Techniques

You use different sample injection techniques for split and splitless applications.

Split Injection Technique

In split injection, only a part of the sample transfers into the column. The rest discharges through the split line.

The ratio of the split flow to the column flow (the *split ratio*) determines the amount of sample that enters the chromatographic column. Figure 5-5 illustrates the gas flows for the split injection technique.

You inject the sample into a glass liner inside the heated vaporization chamber. In the chamber, the sample undergoes rapid vaporization. The relatively high gas flow through the injector carries the vaporized sample rapidly down toward the head of the column.

At the column head, the sample splits in the split ratio. A portion of the sample goes into the column, while the remainder is carried out the split line. You set the column flow and the split flow in the **INLET** menu.

Narrow bore columns, which have inherently low column flows, can produce relatively high split ratios.



Hot Empty Needle Injection Technique

To prevent partial sample vaporization within the hot syringe needle and avoid discrimination of higher boiling components, we recommend to use the *Hot Empty Needle Injection Technique*, particularly when performing manual injection. This technique consists of drawing the sample volume into the syringe barrel followed by a small air gap, which ensures the syringe needle is empty. You insert the empty needle into the injector, wait a few seconds, inject the sample rapidly, and immediately remove the syringe. Using the autosampler (AI/AS 3000 or TriPlus) the *Hot Empty Needle Injection Technique* can be automatically selected in the Autosampler Method page of the Data System.

Split injection is suitable for high-concentration sample analysis, headspace analysis, and isothermal analysis.

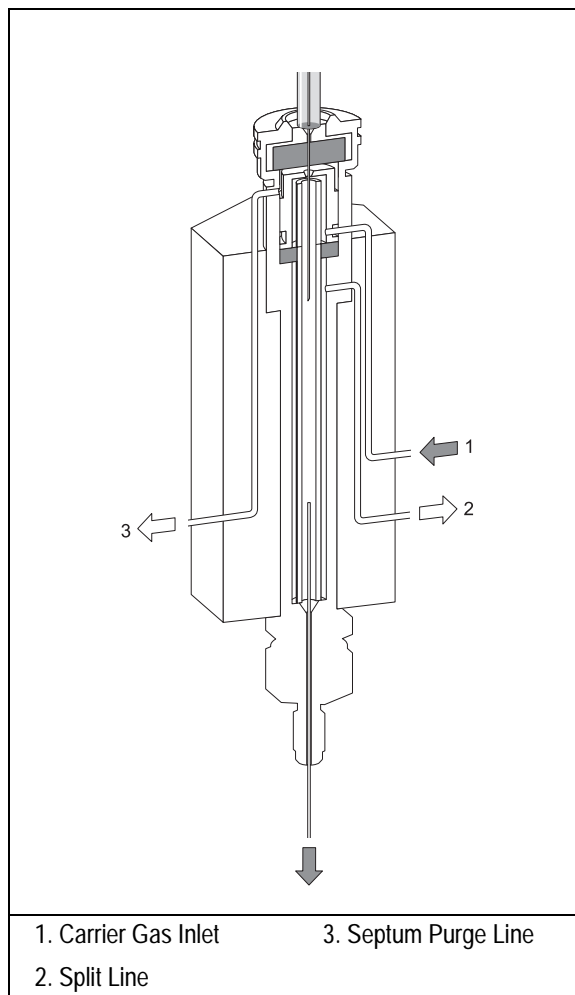

Figure 5-5. Split Injection Technique

The major advantage of split injection is and the ability to introduce samples over a wide range of concentrations. Peak shapes are very sharp due to the rapid sample introduction into the column.

Splitless Injection Technique

Splitless injection is suitable for the analysis of compounds present in very low concentrations.

The splitless technique allows the entire sample to enter the column without splitting. This offers better sensitivity than the split technique.

With splitless injection, the split line is closed during the sample injection and transfer to the column. Once the transfer is over, the split line opens to flush the vaporization chamber of any remaining solvent vapors. Figure 5-6 shows the split/splitless injector when used for splitless injection.

During splitless injection, when the split valves are closed, the flow of gas through the injector is relatively low. It is equal to the column flow only a few mL/min.

The injector can accept and quantitatively transfer to the column sample volumes of up to 5 μL (depending on the solvent type).

With injection volumes higher than 4-5 μL , the recovery of the sample injected is generally improved by closing the septum purge together with the split valve during the splitless period.

You can program this in the **INLET** menu when you select the `Splitless` mode.

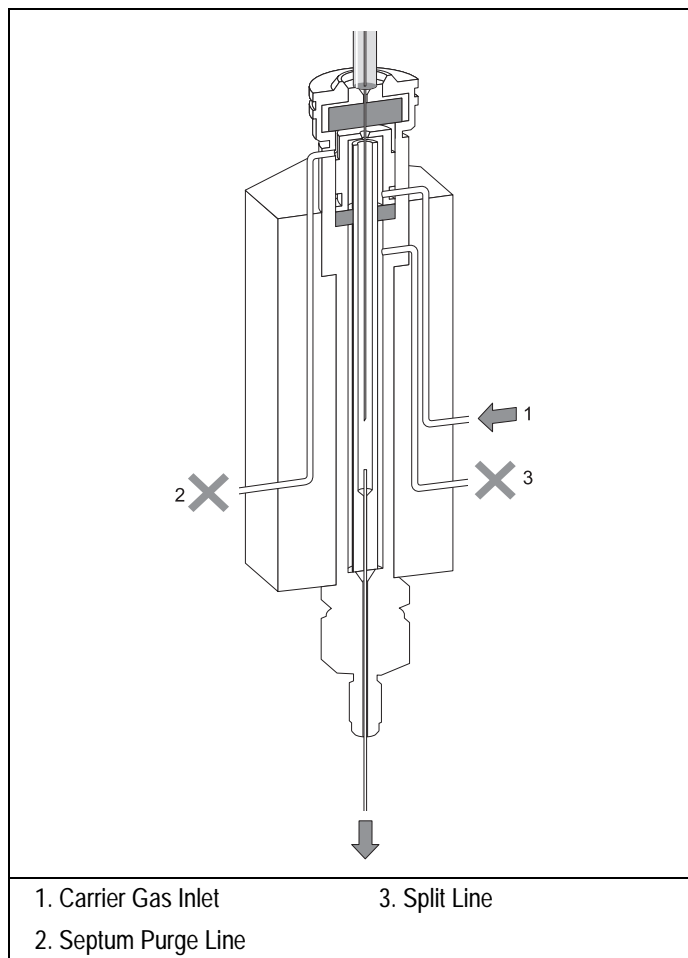

Figure 5-6. Splitless Injection Technique

The transfer of the vaporized sample from the injector to the column takes place slowly due to the low column flows involved. With typical carrier gas flow rates of 1–4 mL/min, the transfer can take between 30 and 90 seconds, depending on a variety of circumstances.

This transfer time should correspond to the *splitless time*. You can set the splitless time in the **INLET** menu when you select *Splitless* mode.

For narrow bore columns (< 0.20 mm ID) with inherently lower flows (< 1.0 mL/min), the transfer is even longer.

You can counter this by using the *splitless surge* pressure mode. In this mode, the pressure in the injector temporarily increases during the splitless period to increase the flow into the column. You set the surge pressure, which activates during the **Prep Run** stage.

At the end of the splitless period, the split valve reopens and the split flow flushes the injector of any remaining solvent vapors. In splitless injection, the absolute split flow is not important. It need only be sufficient to purge the injector. Normally 40–50 mL/min is adequate.

Refocusing the Sample

The sample vapors enter the column over an extended period of time and produce a very broad inlet band. To maintain column efficiency, refocusing must take place in the column inlet before chromatographic process begins.

To achieve this, keep the oven temperature to a sufficiently low value during the injection of the sample to trap it at the column head by condensation (thermal focusing) or solvent effect.

- **Thermal Focussing (or Phase Trapping)**

The components are refocussed by keeping the oven temperature, during injection, at about 80-90 °C below their elution temperature. In these conditions the components are not substantially moving into the column. They are then related as a sharp band when oven temperature is increased. Thermal focusing fails for components that elute at temperature below ca. 100°C since this will imply use of sub-ambient temperatures. For these volatile components refocussing can be obtained by explaining solvent effect.

- **Solvent Effect**

Refocussing by solvent effect presupposes recondensation of solvent in the column inlet. Volatile components are refocussed during the solvent evaporation process into the column. The solvent acts as temporary stationary phase that retains sample components, as the solvent evaporates the components are released as a sharp band. Recondensation of the solvent requires to keep the oven temperature 20-25 °C below the “pressure connected solvent boiling point”.

As a rule of thumb the boiling point increase by about 2-3 °C every 10 kPa up to 100 kPa and 1.5-2 °C every 10 kPa from 100 to 300 kPa.

Flooding

Splitless injections may occasionally exhibit an effect known as *flooding*, which can result in peak distortion.

Peak distortion due to flooding is generally critical only when sample volume exceeds 3-4 μL or when a very polar solvent is used (as methanol) or a narrow bore column (<0.2 mm ID) are used.



NOTE

Hot Empty Needle Injection Technique

To prevent partial sample vaporization within the hot syringe needle and avoid discrimination of higher boiling components, we recommend to use the *Hot Empty Needle Injection Technique*, particularly when performing manual injection. This technique consists of drawing the sample volume into the syringe barrel followed by a small air gap, which ensures the syringe needle is empty. You insert the empty needle into the injector, wait a few seconds, inject the sample rapidly, and immediately remove the syringe.

S/SL Inlet Parameters

The **INLET** menu includes the operating parameters for the split/splitless injector. The parameters you can edit depend on the operating mode chosen: split, splitless, or splitless with surge.

In Main Menu move the cursor until **Inlet** is selected. Press **ENTER** to open **INLET** menu

```

INLET (S/SL)
Mode          Split
  
```

The **Mode** menu items displays the current operating mode. Use **INC** and **DEC** keys to modify the selection.

Use this list box to select one of the following inlet operating mode:

Table 5-2. Inlet Modes

Mode	Description	Parameters to Program
Split	Use this injection mode when analyzing high concentration or neat samples, or in instances where sensitivity is less important. The split vent remains open all the time.	Split Flow Split Ratio
Splitless	The split vent is closed during the injection to drive most of the sample into the column.	Split Flow Splitless Time
Splitless w/surge	Same as Splitless but can also program a surge during an injection. Surge starts at Prep Run and continues until the surge duration time is finished.	Split Flow Splitless Time Surge Pressure Surge Duration

The items in the inlet menu vary depending on the operating mode you select in the **INLET** menu. The following table shows the split/splitless inlet menu for the operating modes.

Split Mode	Splitless Mode	Surge Splitless Mode
INLET (S/SL)	INLET (S/SL)	INLET (S/SL)
Temp 200.. 200	Temp 200..200	Temp 200..200
Mode Split	Mode Splitless	Mode Surge Splitless
Total flow (150.0)	Total flow (150.0)	Total flow (150.0)
Split flow 100 100	Split flow 100 100	Split flow 100 100
Split ratio 1000.0	Splitless time 1.00	Splitless time 1.00
	Const sept purge Off	Surge pressure 100
	Stop purge for 1.00	Surge duration 1.00
		Const sept purge Off
		Stop purge for 1.00

Table 5-3 shows the parameters of the S/SL injector menu.

Table 5-3. Inlet Parameters Menu

Menu	Range	Comments
INLET		This line is the menu title bar.
Temp	50–375 °C	This line shows the base injector temperature.
Mode:	Split, Splitless, Surge Splitless	This line displays the operating mode selected.
Total flow	Not editable	This line shows the total gas flow consumption, which is the sum of the column flow, split flow (or gas saver flow), and septum purge flow.
Split flow	On - Off 10–500 mL/min for He 10-500 mL/min for H ₂ 10-450 mL/min for N ₂ in steps of 1 mL/min	This line shows the split flow. Set ON to display the actual and setpoint values. Press OFF to close the split valve and to turn off the split flow.
Split ratio	1-1000 in steps of 1	This line displays the actual value of the split ratio. This value is the ratio between the split flow and the column flow.

Table 5-3. Inlet Parameters Menu (Continued)

Menu	Range	Comments
Splitless time	0–99.99 min in steps of 0.01 min	This line shows the splitless time, which is the duration of split valve closure.
Surge pressure	10–1000 kPa (2.5–250 kPa) in steps of 1 kPa	Specify the surge pressure to accelerate the transfer process of the substances from the injector to the column. The pressure surge starts in the Prep Run phase and ends at the end of the Surge Duration you program.
Surge duration	0–99.99 min in steps of 0.01 min	This line indicates the duration of the surge pressure after run start.
Const sept purge?	On/Off	Set ON to activate a constant septum purge to continuously flush the septum with a purge flow of 5 mL/min when using helium or nitrogen as a carrier gas or 10 mL/min when using hydrogen as a carrier gas.
Stop purge for:	0–99.99 min in steps of 0.01 min	This line appears only when Constant septum purge is set to Off . Specify the the duration of the split valve closure. Usually, the same time value set in Splitless time is used.

OPERATING SEQUENCE

Programming the Split Mode

In split injection, only a portion of the sample transfers to the column. Most of it discharges through the splitting line. The ratio between the split flow and the column flow defines the amount of sample that enters the chromatographic system. The split and column flows must be set to obtain the correct split ratio necessary for the analysis.

Before you begin programming, do the following:

- Verify that a column is correctly installed, the correct liner is in the injector, and the system is free of leaks.
- Program the carrier gas flow as described in Chapter 3.

Proceed as follows:

Use **INC** and **DEC** keys to increase or decrease the parameter values.

1. In Main Menu move the cursor until **Inlet** is selected. Press **ENTER** to display the **INLET** menu.
2. In the Mode line select **Split**.
3. Scroll to **Temp** and set the appropriate value.
4. Specify the split flow or the split ratio. To set **Split Flow** enter the value in the relevant line. The split ratio will be calculated for you. To set **Split Ratio**, enter the value in the relevant line. The split flow will be calculated for you.
5. If constant septum purge is required, scroll to **Constant Septum Purge** and set **On** to activate a constant septum purge. If constant septum purge is not required, set the **Constant Septum Purge Off**. Scroll to **Stop Purge For:** and enter the time the purge flow should be interrupted.

OPERATING SEQUENCE

Programming the Splitless Mode

In splitless analyses, the splitting line is closed during the sample transfer onto the column. The time during which the splitting valve remains closed is called the *splitless time*. When the sample transfer ends, the split line reopens to purge the residual solvent out of the vaporization chamber. The septum purge prevents septum bleed components from entering the column.

Before you begin programming, do the following:

- Verify that a column is correctly installed, the correct liner is in the injector, and the system is free of leaks.
- Program the carrier gas flow as described in Chapter 3.

Proceed as follows:

Use **INC** and **DEC** keys to increase or decrease the parameter values.

1. In Main Menu move the cursor until **Inlet** is selected. Press **ENTER** to display the **INLET** menu.
2. In the Mode line select **Splitless**.
3. Scroll to **Temp** and set the appropriate value.
4. Scroll to **Split Flow** and enter the desired value.
5. Scroll to **Splitless Time** and enter the time the inlet valve should be closed.
6. If constant septum purge is required, scroll to **Constant Septum Purge** and set **On** to activate a constant septum purge. If constant septum purge is not required, set the **Constant Septum Purge Off**. Scroll to **Stop Purge For:** and enter the time the purge flow should be interrupted.

OPERATING SEQUENCE

Programming the Surge Splitless Mode

In *surge splitless* mode, a carrier gas pressure surge activates during the injection phase for a preset time. This surge accelerates the transfer process of the substances from the injector to the column. The pressure pulse starts in the **Prep Run** phase and ends at the end of the surge duration you program.

Before you begin programming, do the following:

- Verify that a column is correctly installed, the correct liner is in the injector, and the system is free of leaks.
- Program the carrier gas flow as described in Chapter 3.

Proceed as follows:

Use **INC** and **DEC** keys to increase or decrease the parameter values.

1. In Main Menu move the cursor until **Inlet** is selected. Press **ENTER** to display the **INLET** menu.
2. In the Mode line select *Surge Splitless*.
3. Scroll to *Temp* and set the appropriate value.
4. Scroll to *Split Flow* and enter the desired value.
5. Scroll to *Splitless Time* and enter the time the inlet valve should be closed.
6. Scroll *Surge pressure* and enter the value of the pressure surge.
7. Scroll to *Surge duration* and enter the duration of the pressure surge.
8. If constant septum purge is required, scroll to *Constant Septum Purge* and set **On** to activate a constant septum purge. If constant septum purge is not required, set the **Constant Septum Purge Off**. Scroll to *Stop Purge For:* and enter the time the purge flow should be interrupted.

Purged Packed Column Injector (PPKD)

This chapter describes Purged Packed (PPKD) column injector, which has a septum purge. Included in this chapter are PPKD injection techniques and operating sequences.

Chapter at a Glance...

PPKD Overview	114
PPKD Injection Techniques	116
PPKD Injector Menu	116

Operating Sequences

Replacing a Septum	119
Programming the PPKD Injector Wide bore Mode.....	120
Programming the PPKD Injector Surged Wide bore Mode	121
Programming the PPKD Injector Packed Mode.....	122
Programming the PPKD Injector Surged Packed Mode	123

PPKD Overview

The Purged Packed (PPKD) column injector is a packed column injector with a septum purge. The PPKD standard injector accepts wide-bore capillary columns. The sample vaporizes in a liner and enters the wide-bore capillary column. The injector temperature is controllable from 50 °C to 375 °C. Figure 6-1 shows the PPKD injector.

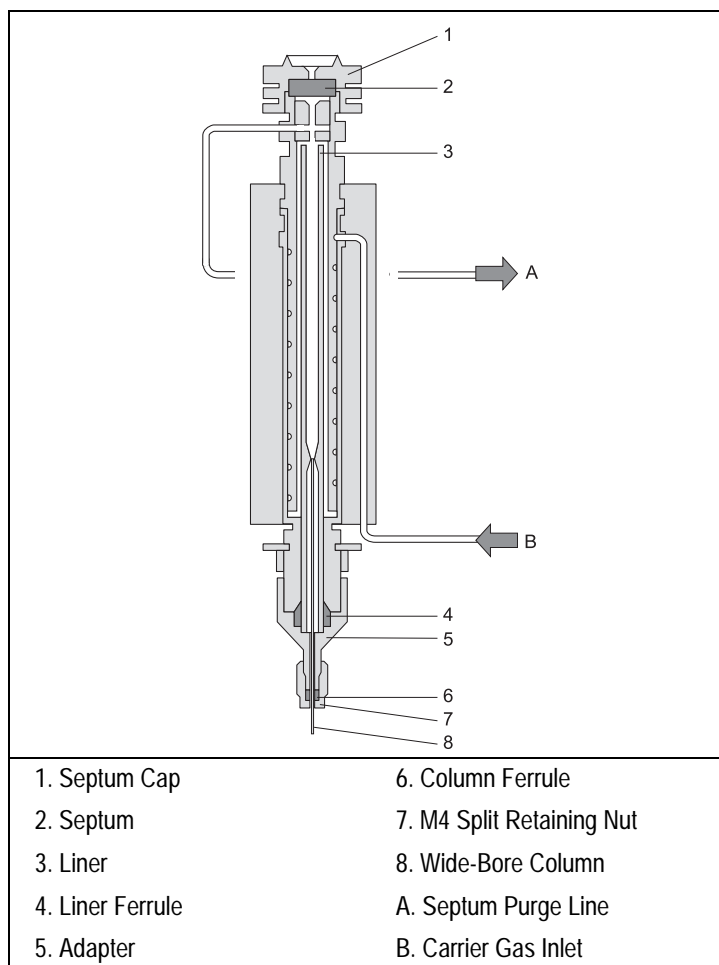

Figure 6-1. Purged Packed Column Injector

Figure 6-2 shows the PPKD injector components.

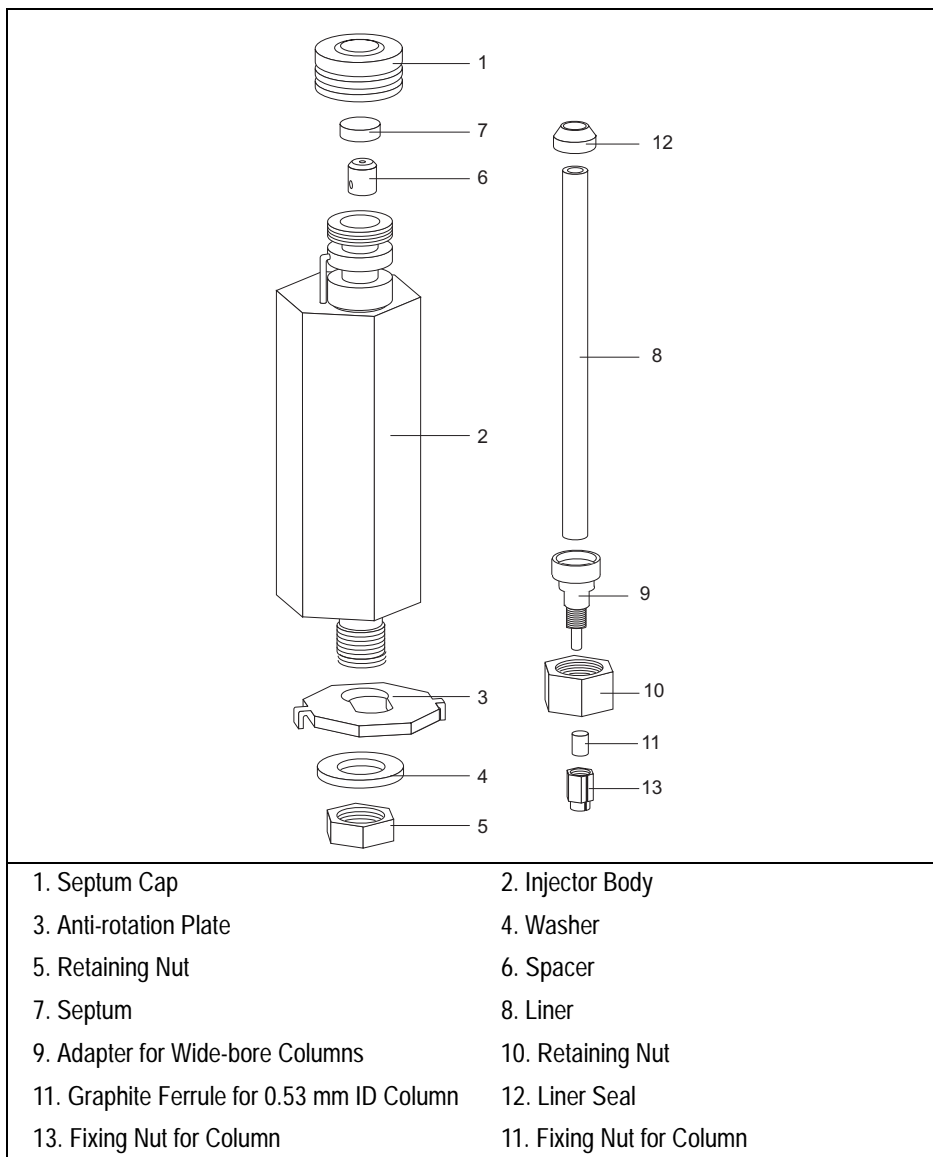

Figure 6-2. PPKD Injector Components

Septa

You should use high temperature septa with a longer life expectancy, good resistance to deformation, and a low bleed level, even at high temperatures. Use high temperature septa for both manual and automatic injections.

Liners

Two different glass liners can be used for wide-bore capillary columns:

- 2 mm ID
- 4 mm ID

PPKD Injection Techniques

The inlet temperature should be sufficiently high to guarantee the sample completely vaporizes while avoiding the possible sample component decomposition.

PPKD Injector Menu

The **INLET** menu includes the operating parameters for the purged packed injector. The parameters you can edit depend on the operating mode chosen: Wide bore, Packed, Wide bore w/surge or Packed w/surge.

In Main Menu move the cursor until **inlet** is selected. Press **ENTER** to open **INLET** menu

INLET (PPKD)	
Mode	Wide bore

The **Mode** menu items displays the current operating mode. Use **INC** and **DEC** keys to modify the selection.

Use this list box to select one of the following inlet operating mode:

Mode	Description	Parameters to set
Packed	The column flow is controlled through true mass flow control.	---
Surged Packed	The column flow is controlled through true mass flow control. A carrier gas pressure surge activates during the injection phase for a preset time.	Surge pressure Surge duration
Wide bore	The column flow is regulated by changing the pressure as the temperature changes.	---
Surged W.bore	The column flow is regulated by changing the pressure as the temperature changes. A carrier gas pressure surge activates during the injection phase for a preset time.	Surge pressure Surge duration

The items in the inlet menu vary depending on the operating mode you select in the **INLET** menu. The following table shows the split/splitless inlet menu for the operating modes.

Packed Mode		Wide bore Mode	
INLET (PPKD)		INLET (PPKD)	
Temp	200..200	Temp	200..200
Mode	Packed	Mode	Wide bore
Const sept purge	Off	Const sept purge	Off
Stop purge for	1.00	Stop purge for	1.00

Surged Packed Mode		Surged Wide bore Mode	
INLET (PPKD)		INLET (PPKD)	
Temp	200..200	Temp	200..200
Mode	Surged Packed	Mode	Surged W.bore
Surge pressure	100	Surge pressure	100
Surge duration	1.00	Surge duration	1.00
Const sept purge	Off	Const sept purge	Off
Stop purge for	1.00	Stop purge for	1.00

Table 6-1. Inlet (PPKD) Menu

Menu	Range	Comments
INLET (PPKD)		This line is the menu title bar.
Temp	50–375 °C	This line shows the base injector temperature.
Mode :	Packed, Surged Packed Wide-bore Surged Wide bore	This line displays the currently selected operating mode. Press ENTER to open the INLET MODE submenu.
Surge pressure	10–1000 kPa (2.5–250 kPa) in steps of 1 kPa	This line indicates the surge pressure. Only used with surged packed and surged w.bore modes.
Surge duration	0–999.9 min	This line displays the duration of surge pressure after run start.
Const sept purge?	On/Off	Set YES to activate a constant septum purge to continuously flush the injector with a purge flow of 5 mL/min for helium and nitrogen or 10 mL/min for hydrogen.
Stop purge for	0–999.9 min	This line appears only when Constant septum purge is set to No.

OPERATING SEQUENCE

Replacing a Septum

Materials required:

- septum
- tweezers



WARNING! The injector fittings may be hot. Make sure the injector is at room temperature before replacing the septum.

1. Remove the septum cap from the injector.
2. Using tweezers, remove the septum from the septum cap.
3. Place a new septum in the septum cap.



CAUTION To avoid contamination, do not touch the septum with your hands.

4. Gently tighten the septum cap onto the injector assembly until finger-tight.

Do not overtighten the septum cap. The septum will deform and may be difficult to penetrate with the syringe needle.

OPERATING SEQUENCE

Programming the PPKD Injector Wide bore Mode

Before programming the purged packed column injector, do the following:

- Verify that a wide-bore column is correctly installed, the correct liner is in the injector and the system is free of leaks.
- Check the oven temperature and detector temperature.
- Program the carrier gas flow as described in Chapter 3.

Proceed as follows:

Use **INC** and **DEC** keys to increase or decrease the parameter values.

1. In Main Menu move the cursor until **Inlet** is selected. Press **ENTER** to display the **INLET** menu.
2. In the Mode line select `Wide bore`.
3. Scroll to `Temp` and set the appropriate injector temperature.
4. If constant septum purge is required, scroll to `Constant Septum Purge` and set `On` to activate a constant septum purge. If constant septum purge is not required, set the `Constant Septum Purge Off`. Scroll to `Stop Purge For:` and enter the time the purge flow should be interrupted.

OPERATING SEQUENCE

Programming the PPKD Injector Surged Wide bore Mode

In the *wide bore w/surge* mode, a carrier gas pressure surge activates during the injection phase for a preset time. This surge accelerates the transfer process of the substances from the injector to the column. The pressure surge starts in the **Prep Run** phase and ends at the end of the programmed *Surge duration*.

Before programming the packed column injector, do the following:

- Verify that a wide-bore column is correctly installed, the correct liner is in the injector, if used, and the system is free of leaks.
- Check the oven temperature and detector temperature.
- Program the carrier gas flow as described in Chapter 3 *Gas Control*.



WARNING! Hydrogen is a potentially dangerous gas. Refer to *Using Hydrogen* for safety information.

Proceed as follows:

Use **INC** and **DEC** keys to increase or decrease the parameter values.

1. In Main Menu move the cursor until **Inlet** is selected. Press **ENTER** to display the **INLET** menu.
2. In the Mode line select *Surged W.bore*.
3. Scroll to *Surge pressure* and enter the value of the pressure surge.
4. Scroll to *Surge duration* and enter the duration of the pressure surge.
5. Scroll to *Temp* and enter the appropriate injector temperature.
6. If constant septum purge is required, scroll to *Constant Septum Purge* and set **On** to activate a constant septum purge. If constant septum purge is not required, set the *Constant Septum Purge* **Off**. Scroll to *Stop Purge For:* and enter the time the purge flow should be interrupted.

OPERATING SEQUENCE

Programming the PPKD Injector Packed Mode

Before programming the purged packed column injector, do the following:

- Verify that a column is correctly installed, the correct liner is in the injector, if used, and the system is free of leaks.
- Check the oven temperature and detector temperature.
- Program the carrier gas flow as described in Chapter 3 *Gas Control*.



WARNING! Hydrogen is a potentially dangerous gas. Refer to *Using Hydrogen* for safety information.

Proceed as follows:

Use **INC** and **DEC** keys to increase or decrease the parameter values.

1. In Main Menu move the cursor until **Inlet** is selected. Press **ENTER** to display the **INLET** menu.
2. In the Mode line select **Packed** and press **ENTER**.
3. Scroll to **Temp** and enter the appropriate injector temperature.
4. If constant septum purge is required, scroll to **Constant Septum Purge** and set **On** to activate a constant septum purge. If constant septum purge is not required, set the **Constant Septum Purge Off**. Scroll to **Stop Purge For:** and enter the time the purge flow should be interrupted.

OPERATING SEQUENCE

Programming the PPKD Injector Surged Packed Mode

In the *Packed w/surge* mode, a carrier gas pressure surge activates during the injection phase for a preset time. This surge accelerates the transfer process of the substances from the injector to the column. The pressure surge starts in the **Prep Run** phase and ends at the end of the programmed *Surge duration*.

Before programming the packed column injector, do the following:

- Verify that a column is correctly installed, the correct liner is in the injector, if used, and the system is free of leaks.
- Check the oven temperature and detector temperature.
- Program the carrier gas flow as described in Chapter 3 *Gas Control*.



WARNING! Hydrogen is a potentially dangerous gas. Refer to *Using Hydrogen* for safety information.

Proceed as follows:

Use **INC** and **DEC** keys to increase or decrease the parameter values.

1. In Main Menu move the cursor until **Inlet** is selected. Press **ENTER** to display the **INLET** menu.
2. In the Mode line select *Surged packed*.
3. Scroll to *Surge pressure* and enter the value of the pressure surge.
4. Scroll to *Surge duration* and enter the duration of the pressure surge.
5. Scroll to *Temp* and press **ON** or enter the appropriate injector temperature using the numeric keypad.
6. If constant septum purge is required, scroll to *Constant Septum Purge* and set **On** to activate a constant septum purge. If constant septum purge is not required, set the *Constant Septum Purge Off*. Scroll to *Stop Purge For*: and enter the time the purge flow should be interrupted.



Column

This chapter describes the analytical column installed in the FOCUS GC oven.

Chapter at a Glance...

Introduction	126
Capillary and Wide-bore Columns	126
Packed Columns	128
Installation	132
Keeping Leaks Under Control	146
Column Conditioning	156

Operating Sequences

How to Connect a Capillary Column	132
How to Connect a Packed Column	138
Manual Checking for Leaks	147
Performing a Column Evaluation	148
Performing an Automatic Leak Check	154

Introduction

The analytical column should be positioned inside the oven. The column ends should align correctly with the injector and detector base body.

Refer to:

- [Capillary and Wide-bore Columns](#)
- [Packed Columns](#)

Capillary and Wide-bore Columns

The capillary column should be positioned inside the oven on the column support.

Using Correct Fittings

To connect a capillary column to the injector and detector base body, you must use the proper column ferrules and retaining nuts.

Column Ferrules

Graphite ferrules are used for many column connections.

- Encapsulated graphite ferrules connect the capillary column to the detector base body and to the injector.



CAUTION

Overtightening compression ferrules does not necessarily produce a stronger, leak-free joint. In fact, very often the reverse is true. Too much pressure can cause a leak in the joint and make it very difficult to reseal that particular joint when changing columns.

Table 7-1 lists the ferrules to use depending on the pre-column and capillary column external diameter. Ferrules that are the wrong size cause leaks and contamination.

Table 7-1. Ferrules

Capillary Column	Graphite Ferrules
0.1 mm ID	0.25 mm ID
0.25 mm ID	0.35 mm ID
0.32 mm ID	0.45 mm ID
0.53 mm ID	0.8 mm ID

Retaining Nuts

M4 split retaining nuts are used to connect capillary columns to injector and detector base bodies. The nuts are split to allow easy installation and removal. Figure 7-1 shows how to connect capillary or wide bore column to injector and detector base body.

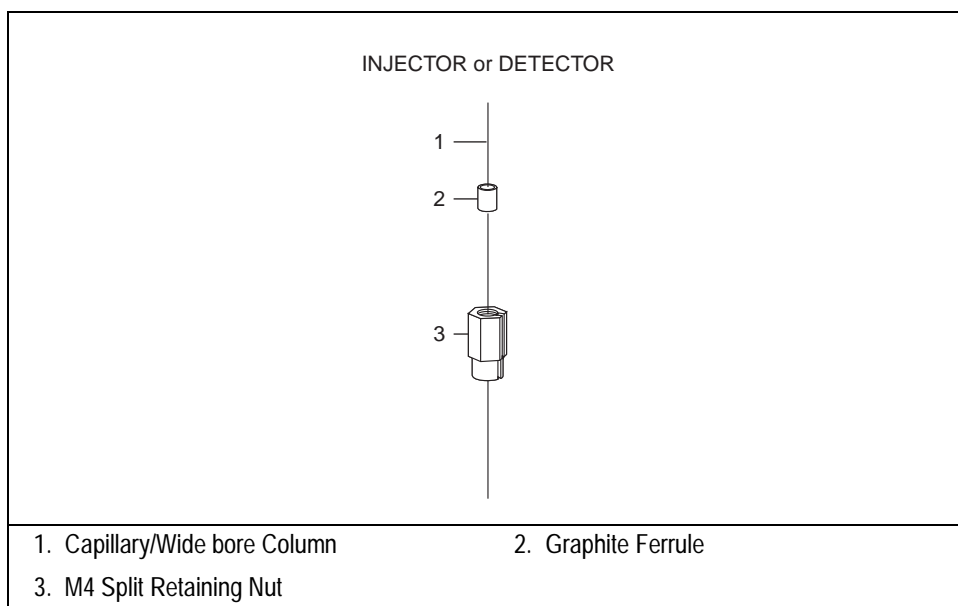

Figure 7-1. Capillary/Wide Bore Column to Injector and Detector Base Body Connections

Packed Columns

There are different sizes of packed columns with both metric and imperial dimensions with dedicated adapters. The FOCUS accepts 1/4 inch OD, 1/8 inch OD imperial metal packed columns, 6 mm OD metric metal packed columns. The metal packed columns can be installed into the S/SL injector by using the appropriate conversion kit.

Metric Packed Columns

The metal 6 mm OD are the metric packed columns most commonly used:

Using Correct Metric Fittings

To connect packed columns to injector and detector base bodies, you must use the correct column ferrules and retaining nuts.

Metric Column Ferrules

Metal packed columns require double brass ferrules (front and back)

Metric Retaining Nuts

Use hexagonal 1/4 inch column retaining nuts to connect all metal packed columns.

Table 7-2 lists the correct fittings for metric packed columns while Figure 7-2 shows the fittings.

Table 7-2. Metric Packed Column Fittings

Column Type	Ferrules	Retaining Nut
6 mm OD metal column	brass double	hexagonal 1/4 inch

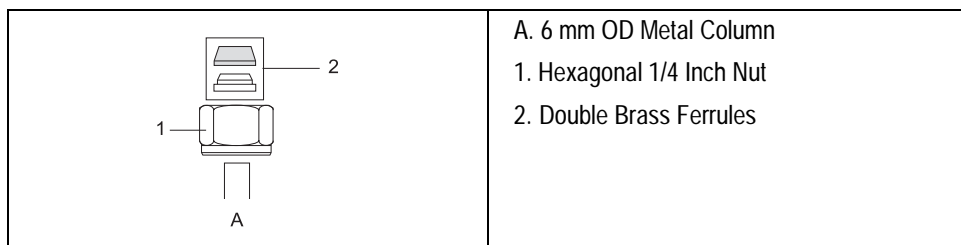

Figure 7-2. Metric Packed Column Fittings

Imperial Packed Columns

The following types of imperial packed columns are commonly used.

- 1/4 inch OD metal packed column
- 1/8 inch OD metal packed column

Using Correct Imperial Fittings

To connect packed columns to injector and detector base bodies, you must use the correct column ferrules and retaining nuts.

Imperial Column Ferrules

- Use Swagelok® ferrules (front and back) with a 1/4 inch hexagonal nut to connect 1/4 inch metal packed columns to injector and detector metric/imperial adapters.
- Use Swagelok® ferrules (front and back), and Swagelok® nuts to connect 1/8 inch metal packed columns to injector and detector metric/imperial adapters.

Imperial Retaining Nuts

- Use Swagelok® nuts to connect all packed columns.

Table 7-3 lists the correct fittings depending on the type of imperial packed column.

Table 7-3. Imperial Size Packed Column Fittings

Column Type	Ferrules	Retaining Nut
metal column 1/4 inch	Swagelok® 1/4 inch	hexagonal 1/4 inch
metal column 1/8 inch	Swagelok® 1/8 inch	Swagelok® 1/8 inch

The adapters size depends on the type of column that has to be use: 6-mm, 1/4-inch, 1/8-inch OD.

To connect metal packed columns to the PPKD injector and the detector base bodies, you must use a proper metal metric/imperial adapter. Figure shows an example of adapters.

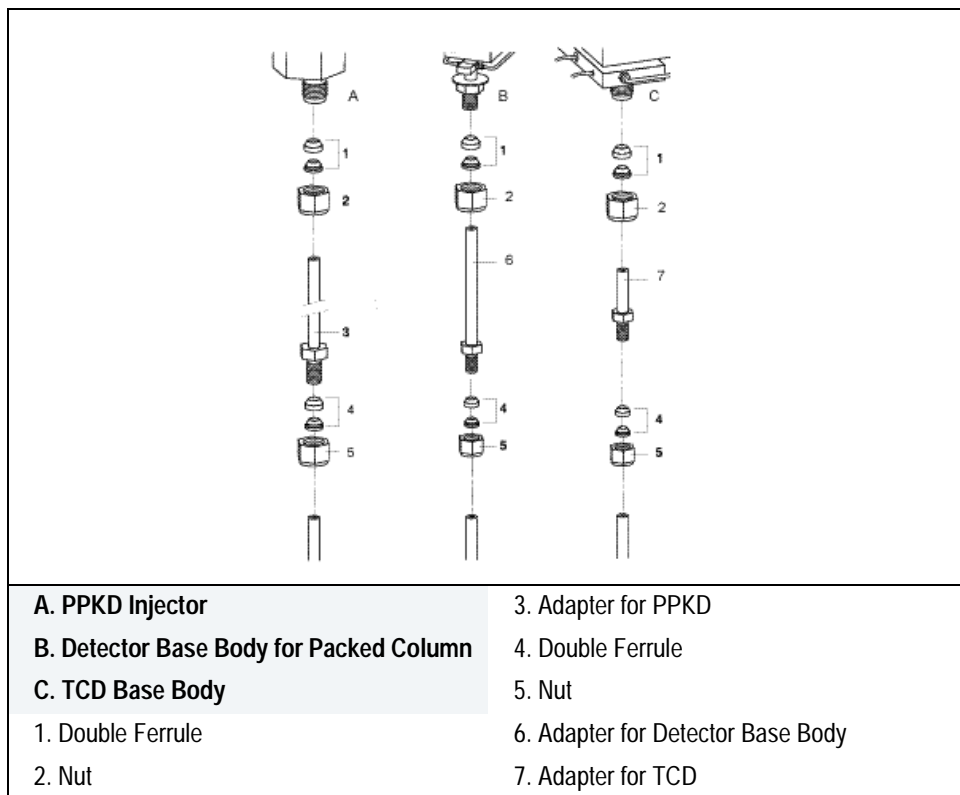

Figure 7-3. Injector and Detector Base Body Adapters



Metal Packed Column may be installed into the S/SL injector and the detector base body for capillary column by using the appropriate conversion kit as shown in Figure 7-4.

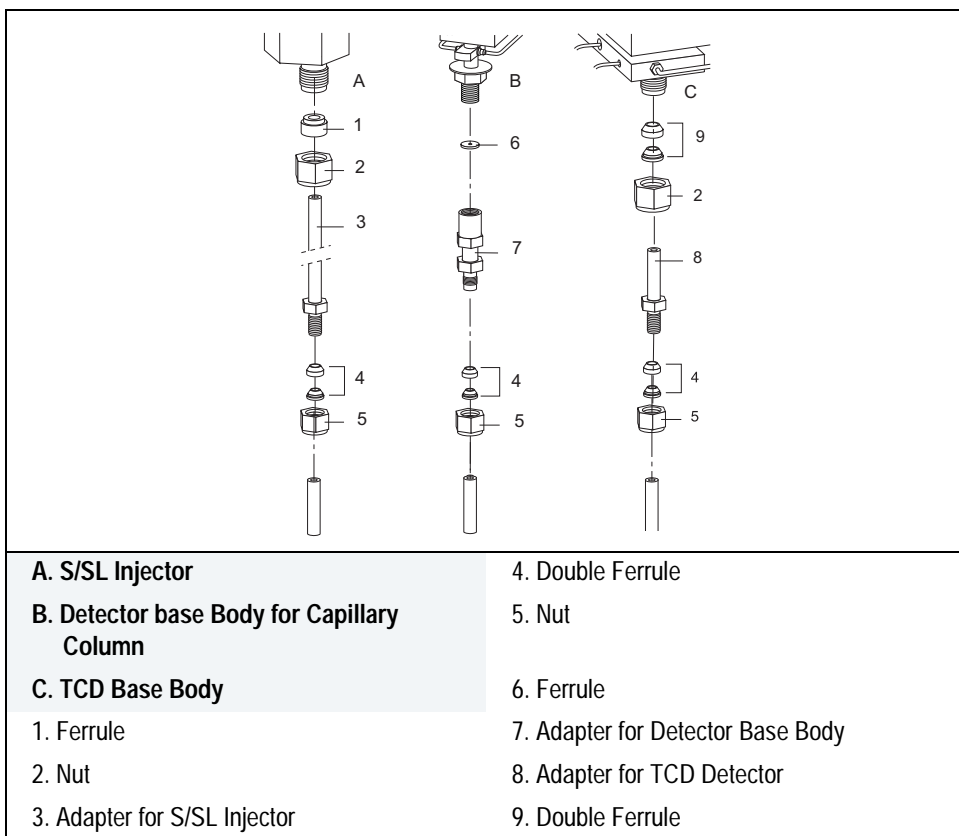

Figure 7-4. Conversion Kit

Installation



CAUTION Each column has a maximum recommended operating temperature. To protect the column from excessively high temperatures, remember to set the **Max temp** parameter for the column oven in the *Oven Configuration Menu* as described in Chapter 2.

According to the analytical column in use refer to:

- *How to Connect a Capillary Column* Operating Sequence.
- *How to Connect a Packed Column* Operating Sequence.

OPERATING SEQUENCE

How to Connect a Capillary Column

To install the capillary column, the following sequential steps should be performed:

- *Installing the Column Support*
- *Preparing a Capillary Column*
- *Connecting to an S/SL Injector*
- *Connecting to an PPKD Injector*
- *Connecting to a FID Detector*
- *Connecting to a TCD Detector*

Installing the Column Support

To install the column support into the GC oven, insert the four pins into the corresponding button-holes on the ceiling of the GC oven.

Preparing a Capillary Column

To prepare metal or fused silica capillary column operate as follows:



CAUTION

Wear safety glasses to protect your eyes from flying particles while handling, cutting, or installing columns. Be careful handling columns to avoid accidental hand injuries.

Fused Silica Capillary Column

To obtain a correct cut of fused silica capillary column, use ceramic scoring wafer or sapphire scribe.

Materials required:

- ceramic scoring wafer
1. Hold the capillary column between your thumb and index finger with the column extending past the tip of your index finger.
 2. Score the column very gently. Excessive force could crush the column end.
 3. Snap off the end of the column.
 4. Inspect the column end for an even, flat cut.

Metal Capillary Column

To obtain a correct cut of metal capillary column, use a triangular file.

Materials required:

- Triangular file
1. Hold the capillary column between your thumb and index finger with the column extending past the tip of your index finger.
 2. Score all round the column very gently.
 3. Snap off the end of the column.
 4. Inspect the column end for an even, flat cut.

Connecting to an S/SL Injector

Before connecting the column, make sure the injector has been properly assembled and programmed and the column support has been installed in the GC oven. For more information about split/splitless injectors, refer to Chapter 5 *Split/Splitless Injector (S/SL)*.

Materials required:

- M4 column retaining nut
 - graphite ferrule
 - typewriter correction fluid or a felt-tipped pen
 - 6 mm wrench
1. Slide the graphite ferrule onto the capillary column with the beveled end facing the injector. Be careful to avoid damaging the graphite ferrule when inserting the column.
 2. Cut at least 1 cm from the column end.
 3. Place the column on the column support.
 4. Use typewriter correction fluid or a felt-tipped pen to mark the correct position of the ferrule from the end of the column depending on the injection technique. The correct positions are as follows:
 - 40 mm for split injection
 - 64 mm for splitless injection
 - 50 mm for splitless injection when using a packed liner
 5. Insert the column about 2 cm into the injector and slide the ferrule on the column up to the injector base, then slide the retaining nut onto the column through the side cut. The FOCUS GC retaining nuts have a slotted design that makes them easy to add and remove.
 6. Finger-tighten the column retaining nut until it starts to grip the column.
 7. Adjust the column position so that the mark is even with the column retaining nut.

8. Use the 6 mm wrench to tighten the retaining nut using no more pressure than is necessary to obtain a good seal (1/4 to 1/2 turn).
9. Conduct a leak check of the column installation, as described in the paragraph *Keeping Leaks Under Control* on page 146.

Connecting to an PPKD Injector

Before connecting the column, make sure the injector has been properly assembled and programmed and the column support has been installed in the GC oven. For more information about Purged Packed injectors, refer to Chapter 6 *Purged Packed Column Injector (PPKD)*.

Materials required:

- M4 column retaining nut
 - graphite ferrule
 - 6 mm wrench
1. Slide the graphite ferrule onto the wide-bore column with the bevelled end facing the injector. Be careful to avoid damaging the graphite ferrule when inserting the column.
 2. Cut 1 cm from the column end.
 3. Place the column on the column support.
 4. Insert the column into the injector and slide the ferrule up to the injector base as far as possible.
 5. Slide the M4 retaining nut onto the column through its side cut.
 6. Finger-tighten the column retaining nut until it starts to grip the column.
 7. Adjust the column position so that its end rests against the bottom of the liner.
 8. Use the 6 mm wrench to tighten the retaining nut. Use no more pressure than is necessary to obtain a good seal (1/4 to 1/2 turn).

9. Conduct a leak check of the column installation, as described in the paragraph *Keeping Leaks Under Control* on page 146.

Connecting to a FID Detector

It is a good practice, before connecting the column to the detector, to perform a manual leak check as described in the *Manual Checking for Leaks* operating sequence.

Before beginning this sequence, remove the detector from the detector base body.



WARNING! The metal capillary column must never touch the tip of the jet. Contact of the metal column with the electrically charged tip can cause electrical shock and damage to the instrument.

Materials required

- M4 column retaining nut
 - graphite ferrule
 - 6 mm wrench
 - typewriter correction fluid, or felt-tipped pen
1. Slide the graphite ferrule onto the capillary column with the beveled end facing the detector base body. Be careful to avoid damaging the graphite ferrule when inserting the column.
 2. Cut 2–3 cm from the column end.
 3. Use the typewriter correction fluid, or felt-tipped pen to mark the column **80-85** mm from the column end.
 4. Gently insert the column into the detector base body. Use the mark as a guide to determine how far to insert the column.
 5. Slide the ferrule up to the detector base body. Slide the M4 nut onto the column through its side cut. Finger-tighten the column retaining nut until it starts to grip the column.



WARNING! Do not push the column through the detector jet because, with the detector in place, the tip of the jet is polarized to high voltage.

6. Use the 6 mm wrench to tighten the retaining nut. Use no more pressure than is necessary to obtain a good seal (1/4 to 1/2 turn).

Connecting to a TCD Detector

It is a good practice, before connecting the column to the detector, to perform a manual leak check as described in the [Manual Checking for Leaks](#).operating sequence.

Before you connect the capillary column to the TCD, be sure to do the following:

- condition the column
- make sure the capillary column adapter is mounted on the detector base body

Materials required:

- M4 column retaining nut
 - graphite ferrule
 - 6 mm wrench
 - capillary column adapter
1. Connect the capillary column adapter to the detector base body.
 2. Slide the graphite ferrule onto the column with the beveled end facing the injector. Be careful to avoid damaging the graphite when inserting the column.
 3. Cut 2–3 cm from the column end.
 4. Insert the column into the detector adapter and slide the ferrule up to the detector base body as far as possible.
 5. Slide the M4 retaining nut onto the column through its side cut.
 6. Finger-tighten the retaining nut until it starts to grip the column.
 7. Push the column all the way up into the detector, then pull the column back about 1 mm.

8. Tighten the M4 retaining nut using the 6 mm wrench. Use no more pressure than is necessary to achieve a good seal (1/4 to 1/2 turn).

OPERATING SEQUENCE

How to Connect a Packed Column

To install the packed column, the following sequential steps should be performed:

- *Preparing a Metal Packed Column*
- *Connecting a Packed Column to a PPKD Injector*
- *Connecting a Packed Column to the S/SL Injector*
- *Connecting a Packed Column to the TCD Detector*

Preparing a Metal Packed Column

Before you begin, verify that the proper adapters are installed on the injector and detector side.

Slide the fittings onto the packed column injector and detector ends in the order and direction shown in Figure 7-5.

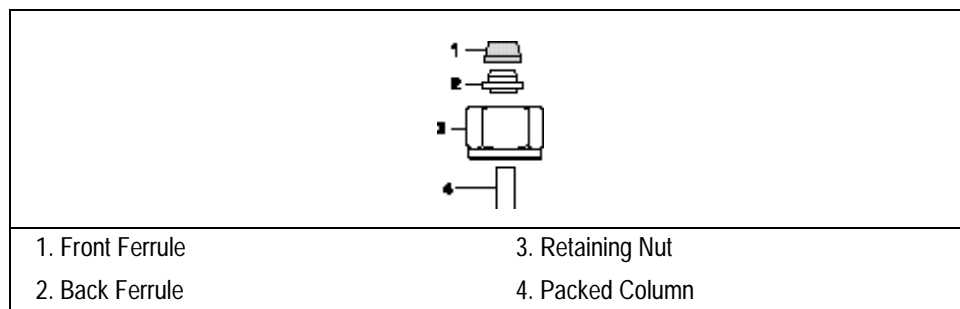

Figure 7-5. Metal Packed Column Fittings

Connecting a Packed Column to a PPKD Injector

Materials required:

- retaining nut
 - ferrules
 - 10 mm or 1/4 inch wrench
 - adapter for injector
1. Make sure that your packed column has been correctly prepared.
 2. Insert the appropriate adapter into the bottom of the injector, then push up the adapter into the injector as far as possible.
 3. Slide the ferrule up to injector base then finger-tighten the adapter retaining nut until it starts to grip the adapter.
 4. Use the wrench to tighten the retaining nut. Use no more pressure than is necessary to obtain a good seal (1/4 to 1/2 turn).
 5. Insert the inlet end of the column to the adapter base as far as possible.
 6. Slide the ferrule up to adapter base then finger-tighten the column retaining nut until it starts to grip the column.
 7. Use the wrench to tighten the retaining nut. Use no more pressure than is necessary to obtain a good seal (1/4 to 1/2 turn).



CAUTION

Overtightening the compression ferrule does not necessarily produce a stronger, leak-free joint. In fact, very often the reverse is true. Overtightening can cause a leak in the joint and make it very difficult to reseal that particular joint when changing columns.

Connecting a Packed Column to the S/SL Injector

Materials required:

- liner cap removal tool
- retaining nut
- ferrules
- metal adapter

1. Remove the S/SL Injector Top Components.
With reference to Figure 7-6 proceed as follows:

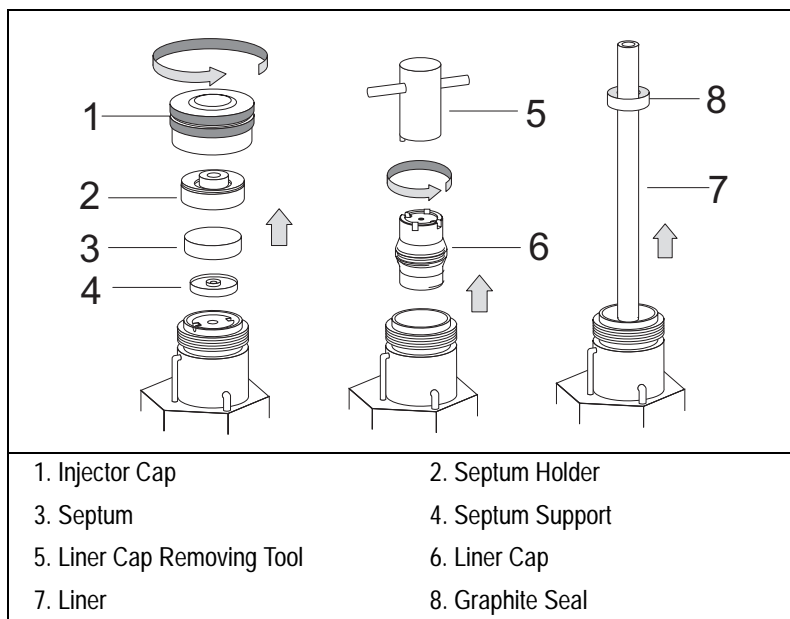

Figure 7-6. Removing the S/SL Injector Top Components

- a. Unscrew the injector cap.
- b. Remove the septum holder with septum. then the septum support.
- c. Remove the liner cap by using the tool provided.
- d. Use tweezers to remove the liner with the graphite seal.

2. Remove the S/SL Injector Bottom Components.
With reference to Figure 7-7 proceed as follows:

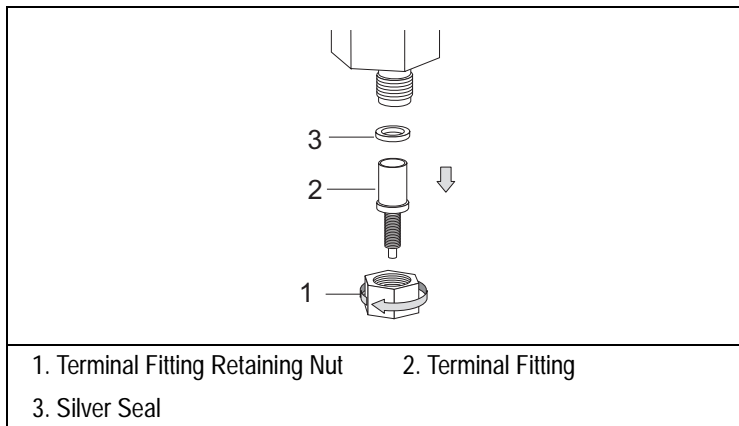

Figure 7-7. Removing the S/SL Injector Bottom Components

- a. Unscrew the retaining nut at the bottom of the injector.
 - b. Remove the terminal fitting and the silver seal.
3. Install the metal adapter.
With reference to Figure 7-8 proceed as follows:

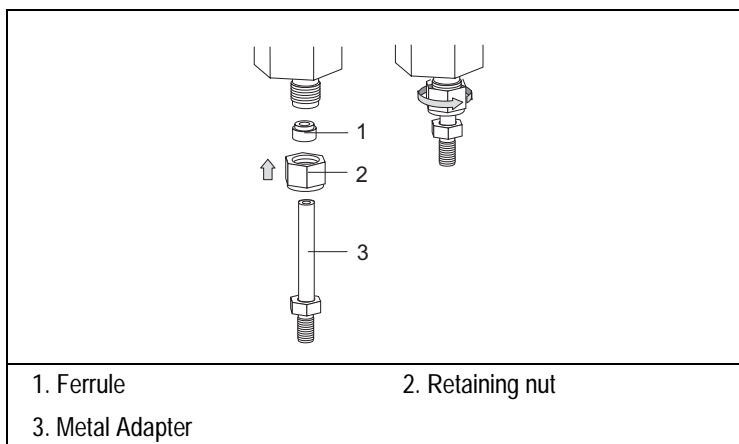

Figure 7-8. Metal Adapter Installation

- a. Slide the appropriate nut and ferrule onto the metal adapter, then insert it into the bottom of the injector.
- b. Push the metal adapter into the injector as far as possible.
- c. Slide the ferrule up the injector base then finger-tighten the retaining nut until it starts to grip the metal liner.
- d. Slide the appropriate graphite seal and push it onto the metal adapter from the top of the injector by using the appropriate tool as shown in Figure 7-9.

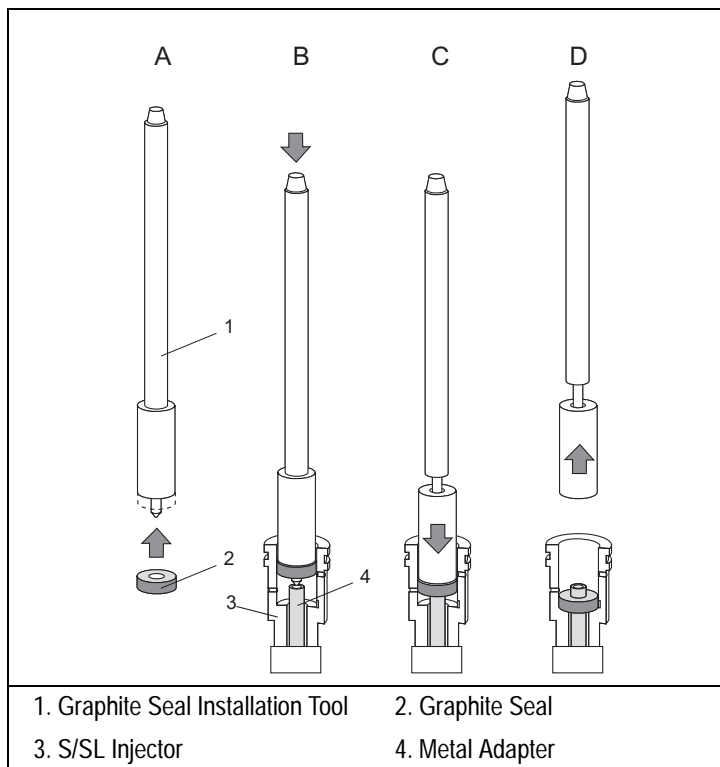

Figure 7-9. Graphite Seal Installation Tool

4. Reinstall the S/SL Top Components.
With reference to Figure 7-10 proceed as follows:

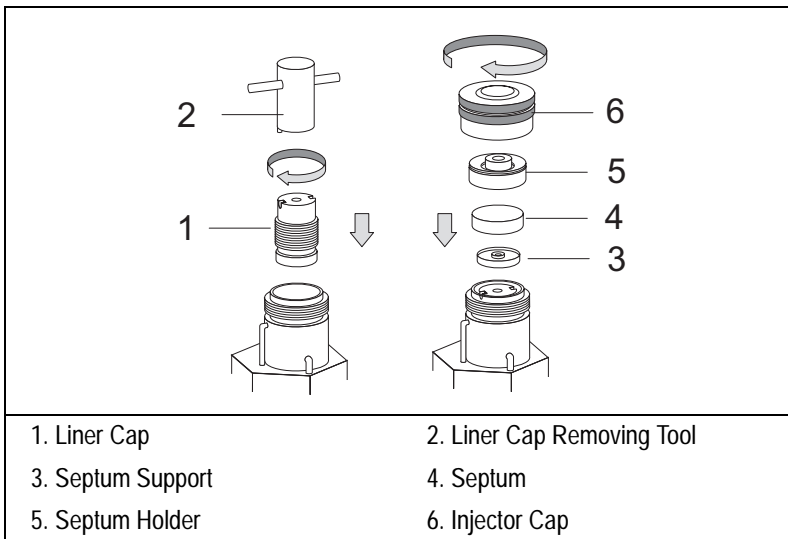

Figure 7-10. Reinstalling the S/SL Injector Top Components

- a. Reinstall and tighten the liner cap until it start to grip the graphite seal then tighten the metal adapter retaining nut.
 - b. Reinstall the septum support, septum, septum holder then screw the injector cap.
5. Connect the Packed Column.
With reference to Figure 7-11 proceed as follows:

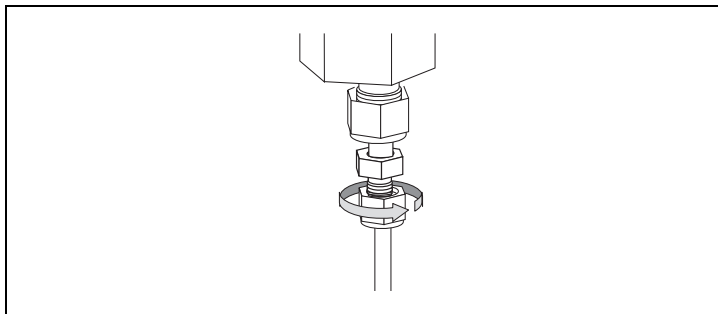

Figure 7-11. Connecting the Packed Column

- a. Make sure that your packed column has been correctly prepared as described in the *Preparing a Metal Packed Column*.
- b. Insert the column end to the metal adapter paying attention that the column end touches the bottom
- c. Finger-tighten the column end retaining nut until they start to grip the column.
- d. Tighten the column retaining nut.



CAUTION

Overtightening the compression ferrule does not necessarily produce a stronger, leak-free joint. In fact, very often the reverse is true. Overtightening can cause a leak in the joint and make it very difficult to reseal that particular joint when changing columns.

Connecting a Packed Column to the TCD Detector

Materials required:

- metric/imperial retaining nut
 - metric/imperial ferrules
 - 10 mm or 1/4 inch wrench
 - adapter for detector
1. Insert the appropriate adapter into the bottom of the detector base, then push up the adapter into the detector base as far as possible.
 2. Slide the ferrule up to detector base then finger-tighten the adapter retaining nut until it starts to grip the adapter.
 3. Use the wrench to tighten the retaining nut. Use no more pressure than is necessary to obtain a good seal (1/4 to 1/2 turn).
 4. Insert the detector end of the column to the adapter base as far as possible.
 5. Slide the ferrule up to adapter base then finger-tighten the column retaining nut until it starts to grip the column.

6. Use the wrench to tighten the retaining nut. Use no more pressure than is necessary to obtain a good seal (1/4 to 1/2 turn).

**CAUTION**

Overtightening the compression ferrule does not necessarily produce a stronger, leak-free joint. In fact, very often the reverse is true. Overtightening can cause a leak in the joint and make it very difficult to reseal that particular joint when changing columns.

Keeping Leaks Under Control

FOCUS GC features a series of automatized operations that make easier the task of keeping under control the tightness of your system.

The sequence *Manual Check for Leaks - Column Evaluation - Automatic Leak Check* is the key for minimizing troubles related to leaks.

After you install a column you must perform a manual leak check and column evaluation then you can use the automatic leak function at any time in the future to check for leaks

Column Evaluation

Once the leak has been removed and the tightness of the system is reasonably sure, you should perform the *Column Evaluation* automatic control and compare the response with the *K Factor* values reported in *K Factor Tables*. Refer to *Performing a Column Evaluation* operating sequence.

If the value obtained does not agree with the one reported on the card, this means that the leaks have not been repaired.

Performing the *Column Evaluation* is the necessary condition for the success of any subsequent *Automatic Leak Check*.

Identifying and Removing Leaks

If the *Automatic Leak Check* (or any significant symptom) has notified a possible leak in the system, you should:

- Check the whole system for leaks, from the carrier gas inlet to the detector.
- Check the accessible, critical connections (column to injector, column to detector, split an purge valves, septum caps).

A possible leaks source may be the gas bottles/gas chromatograph connections. Check these lines before the others, if specific symptoms indicate that the leak is outside the gas chromatograph.

Refer to *Performing an Automatic Leak Check*

OPERATING SEQUENCE

Manual Checking for Leaks

Before you begin this sequence, you must install the column into the injector, but not into the detector base body.

Materials needed:

- silicon rubber septum of any dimension
1. Carefully push the detector end of the capillary column into the rubber septum to seal it.
 2. Set split and purge valves Off. See *Controlling Valves*.
 3. Increase the carrier gas pressure to 150–200 kPa and allow the column and injector pressure to stabilize. This can take up to 30 seconds.
 4. Reduce the pressure to 50 kPa.
 5. Observe the actual pressure. In a leak-tight system, the pressure should not drop more than 1 kPa/minute.
 6. If your installed column is leak tight, remove the septum and prepare the end of the column for installation into the detector.
 7. If it is not leak tight, check the tightness of the column ferrule and repeat the leak check sequence.

OPERATING SEQUENCE

Performing a Column Evaluation

The column flow control in the FOCUS GC is *indirect*. This means that the GC regulates *pressure* to control the flow of gas through the column. To do this, the GC relies on a *column constant*. The column constant is a measure of the columns pneumatic resistance. Use the FOCUS GC's column evaluation feature to automatically calculate the column constant.

To perform the column evaluation, the system uses the correlation between the applied pressure to the flow and the column temperatures. This operation must be carried out every time a new column is installed. Before performing the column evaluation, a *manual checking for leaks* of the system must be carried out.

The GC must not be performing a run and must be isothermally stable before you can perform a column evaluation.

1. In Main Menu move the cursor until **Carrier** is selected, then press **ENTER**.

```
CARRIER (He)
Column evaluation
```

2. Scroll to **Column evaluation** and press **ENTER** to open **COLUMN EVALUATION** menu.

```
COLUMN EVALUATION
Run column eval.
K = 1.0
Exit w/o column eval
```

3. To start column evaluation, scroll to **Run column eval** and press **ENTER**.



NOTE

To exit Column evaluation menu without performing column evaluation, scroll to **Exit w/o column evaluation** and press **ENTER**.

Column evaluation cannot be started in the following cases:

or

COLUMN EVALUATION
Oven not ready

or

COLUMN EVALUATION
Carrier press. Off!

or

COLUMN EVALUATION
GC running

or

COLUMN EVALUATION
Packed mode!

4. The GC automatically performs column evaluation.



NOTE

To abort column evaluation, scroll to **Abort column eval.** and press **ENTER**. The message **Aborted by operator** will be displayed.

5. After a few minutes the following message will be displayed. Compare the response with the K Factor values reported in paragraph ***Expected K Factor*** according to the *carrier gas used*.

COLUMN EVALUATION
Completed K=1.0

6. If the value obtained does not agree with the one reported on the ***K Factor Tables***, this means that the leaks have not repaired.



NOTE

Performing the Column Evaluation is the necessary condition for the success of any subsequent Automatic Leak Check.

7. In case of error, the following messages may be displayed.

COLUMN EVALUATION Err! Too low P drop
--

COLUMN EVALUATION Err! Too High P drop.
--

Expected K Factor

The following tables indicate the expected K factors for columns of ideal dimensions when using helium, hydrogen, or nitrogen as a carrier gas. Use this information when interpreting results from a Column Evaluation. Deviations of 10-15% from the value reported in this chart are normal and occur due to dimensional tolerances. For example, a 30 m x 0.25 mm column will typically give K factors of 1.5–2.0. Large deviations from the expected values will indicate leaks in the septum or column ferrule or a plugging of the column at the inlet or exit points.



NOTE

Porous layer open tubulat (PLOT) columns will exhibit actual K factor higher than the expected values, depending on the particles packing.

K Factor Tables

- *Helium Carrier Gas Theoretical K Factor*
- *Nitrogen Carrier Gas Theoretical K Factor*
- *Hydrogen Carrier Gas Theoretical K Factor*

Helium Carrier Gas Theoretical K Factor

		COLUMN ID (mm)							
		0.10	0.15	0.18	0.20	0.22	0.25	0.32	0.53
COLUMN LENGTH (m)	2.5	5.55	1.095	0.53	0.347	0.237	0.142	0.053	
	5	11.1	2.19	1.06	0.694	0.474	0.284	0.106	0.014
	6	13.3	2.63	1.27	0.833	0.569	0.341	0.127	0.017
	7	15.5	3.07	1.48	0.971	0.663	0.398	0.148	0.020
	8	17.8	3.51	1.69	1.11	0.758	0.455	0.169	0.022
	9	20.0	3.95	1.90	1.25	0.853	0.511	0.191	0.025
	10	22.2	4.39	2.11	1.39	0.948	0.568	0.212	0.028
	15		6.58	3.17	2.08	1.42	0.852	0.318	0.042
	20		8.77	4.23	2.78	1.90	1.14	0.423	0.056
	25		11.0	5.29	3.47	2.37	1.42	0.529	0.070
	30		13.2	6.34	4.16	2.84	1.70	0.635	0.084
	35		15.3	7.40	4.86	3.32	1.99	0.741	0.098
	40		17.5	8.46	5.55	3.79	2.27	0.847	0.113
	45		19.7	9.52	6.24	4.26	2.56	0.953	0.127
	50		21.9	10.6	6.94	4.74	2.84	1.06	0.141
	55		24.1	11.6	7.63	5.21	3.13	1.16	0.155
	60			12.7	8.33	5.69	3.41	1.27	0.169
	65			13.7	9.02	6.16	3.69	1.38	0.183
	70			14.8	9.71	6.63	3.98	1.48	0.197
	75			15.9	10.4	7.11	4.26	1.59	0.211
80			16.9	11.1	7.58	4.55	1.69	0.225	
85			18.0	11.8	8.06	4.83	1.80	0.239	
90			19.0	12.5	8.53	5.11	1.91	0.253	
95			20.1	13.2	9.00	5.40	2.01	0.267	
100			21.1	13.9	9.48	5.68	2.12	0.281	
105			22.2	14.6	9.95	5.97	2.22	0.295	

Nitrogen Carrier Gas Theoretical K Factor

		COLUMN ID (mm)							
		0.10	0.15	0.18	0.20	0.22	0.25	0.32	0.53
COLUMN LENGTH (m)	2.5	4.95	0.98	0.471	0.309	0.2155	0.126	0.047	
	5	9.90	1.96	0.943	0.619	0.423	0.253	0.094	0.012
	6	11.9	2.35	1.13	0.743	0.507	0.304	0.113	0.015
	7	13.9	2.74	1.32	0.866	0.592	0.355	0.132	0.017
	8	15.8	3.13	1.51	0.990	0.676	0.406	0.151	0.020
	9	17.8	3.52	1.70	1.11	0.761	0.456	0.170	0.022
	10	19.8	3.91	1.89	1.24	0.845	0.507	0.189	0.025
	15	29.7	5.87	2.83	1.86	1.27	0.760	0.283	0.037
	20		7.82	3.77	2.48	1.69	1.01	0.378	0.050
	25		9.78	4.72	3.09	2.11	1.27	0.472	0.063
	30		11.7	5.66	3.71	2.54	1.52	0.566	0.075
	35		13.7	6.60	4.33	2.96	1.77	0.661	0.088
	40		15.6	7.54	4.95	3.38	2.03	0.755	0.100
	45		17.6	8.49	5.57	3.80	2.28	0.850	0.113
	50		19.6	9.43	6.19	4.23	2.53	0.944	0.125
	55		21.5	10.4	6.81	4.65	2.79	1.04	0.138
	60			11.3	7.43	5.07	3.04	1.13	0.151
	65			12.3	8.04	5.49	3.29	1.23	0.163
	70			13.2	8.66	5.92	3.55	1.32	0.176
	75			14.1	9.28	6.34	3.80	1.42	0.188
80			15.1	9.90	6.76	4.06	1.51	0.201	
85			16.0	10.5	7.18	4.31	1.61	0.213	
90			17.0	11.1	7.61	4.56	1.70	0.226	
95			17.9	11.8	8.03	4.82	1.79	0.238	
100			18.9	12.4	8.45	5.07	1.89	0.251	
105			19.8	13.0	8.87	5.32	1.98	0.263	

Hydrogen Carrier Gas Theoretical K Factor

		COLUMN ID (mm)							
		0.10	0.15	0.18	0.20	0.22	0.25	0.32	0.53
COLUMN LENGTH (m)	2.5	2.49	0.492	0.237	0.155	0.106	0.063	0.023	
	5	4.98	0.984	0.474	0.311	0.213	0.127	0.047	
	6	5.98	1.18	0.569	0.374	0.255	0.153	0.057	
	7	6.97	1.38	0.664	0.436	0.298	0.178	0.066	
	8	7.97	1.57	0.759	0.498	0.340	0.204	0.076	
	9	8.96	1.77	0.854	0.560	0.383	0.229	0.085	
	10	9.96	1.97	0.949	0.623	0.425	0.255	0.095	0.012
	15	14.9	2.95	1.42	0.934	0.638	0.382	0.142	0.019
	20	19.9	3.93	1.90	1.25	0.850	0.510	0.190	0.025
	25	24.9	4.92	2.37	1.56	1.06	0.637	0.237	0.031
	30		5.90	2.85	1.87	1.28	0.765	0.285	0.037
	35		6.89	3.32	2.18	1.49	0.892	0.332	0.044
	40		7.87	3.80	2.49	1.70	1.02	0.380	0.050
	45		8.85	4.27	2.80	1.91	1.15	0.427	0.057
	50		9.84	4.74	3.11	2.13	1.27	0.475	0.063
	55		10.8	5.22	3.42	2.34	1.40	0.522	0.069
	60		11.8	5.69	3.74	2.55	1.53	0.570	0.076
	65		12.7	6.17	4.05	2.76	1.66	0.617	0.082
	70		13.7	6.64	4.36	2.98	1.78	0.665	0.088
	75		14.7	7.12	4.67	3.19	1.91	0.712	0.095
80		15.7	7.59	4.98	3.40	2.04	0.760	0.101	
85		16.7	8.06	5.29	3.61	2.17	0.807	0.107	
90		17.7	8.54	5.60	3.83	2.29	0.855	0.114	
95		18.6	9.01	5.91	4.04	2.42	0.902	0.120	
100		19.6	9.49	6.23	4.25	2.55	0.950	0.126	
105		20.6	9.96	6.54	4.46	2.68	0.997	0.133	

OPERATING SEQUENCE

Performing an Automatic Leak Check

When you perform an automatic *leak check* of the FOCUS GC system, the GC measures the column flow with a true mass flow sensor and compares it to a calculated flow value obtained from the original column constant to see if the numbers match. The instrument detects a gas leak if there is a significant difference between the two values.

To start the leak check operate as follows:

1. In Main Menu move the cursor until **Carrier** is selected, then press **ENTER**.

```
CARRIER (He)
Leak Check
```

2. Scroll to **Leak check** and press **ENTER** to open **Leak Check** menu.

```
LEAK CHECK
Run leak check
Exit w/o leak check
```

3. To start column evaluation, scroll to **Run leak check** and press **ENTER**.
4. The system is automatically pressurized with carrier gas and sealed to perform leak check.



NOTE

To exit **LEAK CHECK** menu without performing column evaluation, scroll to **Exit w/o leak check** and press **ENTER**.

Leak check cannot be started in the following cases:

```
LEAK CHECK
Oven not ready
```

or

```
LEAK CHECK
Carrier press. Off!
```

or

```
LEAK CHECK
GC running
```

or

```
LEAK CHECK
Packed mode!
```



NOTE

To abort leak check, scroll to **Abort leak check.** and press **ENTER**. The message **Aborted by operator** will be displayed.

5. If the system is free of leaks, the following message is displayed.

```
LEAK CHECK
Leak check passed
```

6. If leaks are found, an error message will be displayed. In this case, eliminate leaks and repeat the leak check procedure.

```
LEAK CHECK
Possible leak
```

Note that only a previous *Column Evaluation*, performed in a condition of true tightness, can ensure the validity of the subsequent *Automatic Leak Check* responses.

Column Conditioning

To ensure optimum analytical performance, a new column must be conditioned to remove contaminants and unwanted volatile compounds.

Column conditioning is required to remove volatile contaminants adsorbed from the air.

Column conditioning consists of passing a carrier gas flow through the column and heating the column to a temperature 20–50 °C above the maximum temperature that will be used for running analyses, provided that temperature is within the operating range of the column.

For detailed information on column conditioning of your specific column, refer to the column manufacturer's instructions.



CAUTION

With the column already installed, before starting column conditioning, disconnect the column outlet from the detector. With the column not already installed, connect only the column inlet to the injector.



WARNING!

Do not use hydrogen as carrier gas because it could vent into the oven and present an explosion hazard. Make sure that the system is leak tight before heating the column oven. The column might be irreversibly damaged by the presence of molecular oxygen at high temperature.

Flame Ionization Detector (FID)

This chapter describes the Flame Ionization Detector (FID). Due to its high sensitivity, good operational stability, and wide linear response, the FID remains the most popular detector for gas chromatography.

Chapter at a Glance...

FID Overview	158
FID Gas Supplies.....	161
FID Installation.....	162
FID Menu	164
Detector Signal Parameters	166

Operating Procedures

Programming a FID.....	167
Setting the FID Signal Parameters	169

FID Overview

In the FID, the effluent from the column is mixed with hydrogen and burned in a stream of air as it emerges from the jet. The jet acts as a polarizing electrode, while the metal collar surrounding the flame forms the collecting electrode.

A polarizing voltage is applied across the electrodes from the electrometer unit to accelerate and collect the ions that are generated during the combustion process of organic compounds. The resulting ionization current is sensed by an electrometer amplifier and converted to a suitable output signal. Figure 8-1 shows the FID.

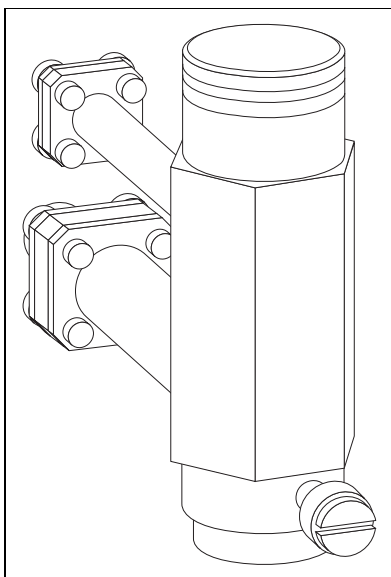

Figure 8-1. Flame Ionization Detector

Detector Base Body

The detector FID is easily interchangeable because of base body that acts as a bridge between the detector and analytical column.

This detector base body, see Figure 8-2, can accept all types of capillary column. The column enters the detector jet directly to eliminate any dead volumes. The base body allows columns to be connected using either M4 or M8 mm fittings.

Detector Gas

FOCUS GC is equipped with a conventional detector gas flow control module (DGFC). See Figure 8-2. The detector gases flows are pre-set in the factory. You may set the flows On or Off.

Refer also to paragraph *FID Gas Supplies*.

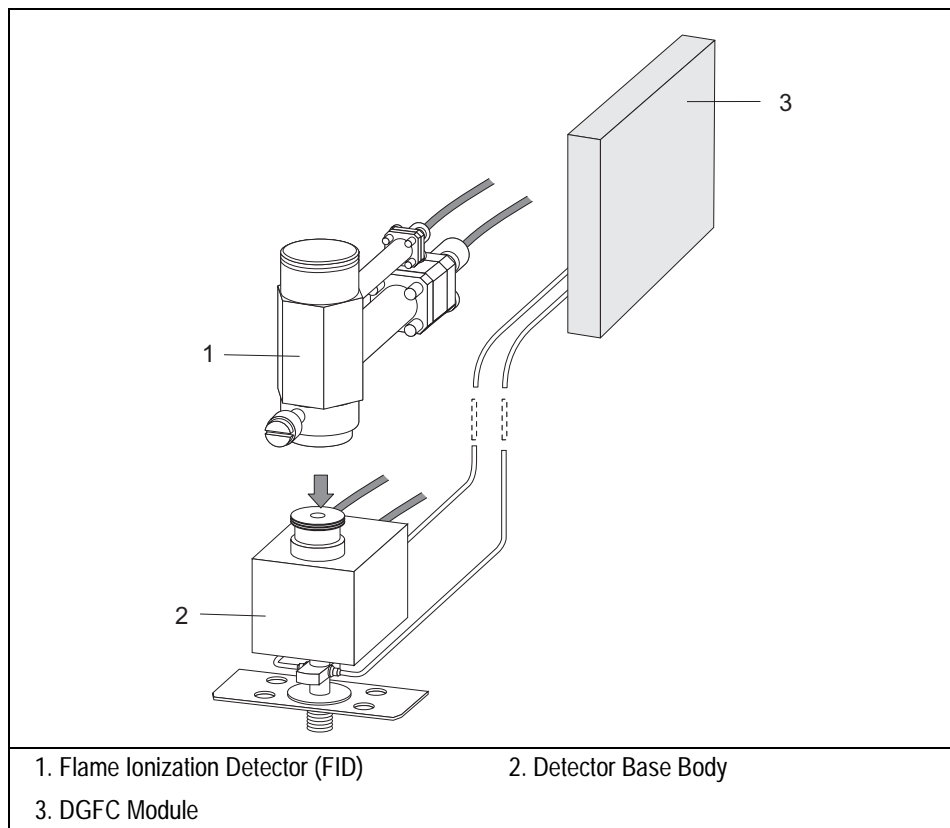

Figure 8-2. FID Detector Base Body and DGFC Module

Jet

The flame jet, mounted on the detector base body for capillary, wide-bore, or packed columns and is suitable for operating up to the max selectable detector temperature (375°C) .

Selectivity

The FID responds to almost all organic compounds containing a carbon-hydrogen bond. The detector does not respond, or responds minimally to permanent gases, oxides of nitrogen, sulfur compounds, ammonia, and water.

Temperature

The detector base body heats the FID to prevent condensation of the water vapor formed as a result of the hydrogen combustion of the flame. The FOCUS GC will not allow flame ignition to proceed at temperatures less than 150 °C. The base body temperature is normally set to the upper temperature limit of the column in use.

FID Gas Supplies

The performance of the FID is affected by the flow of the various gases through the detector.

The fuel and make-up gases used for the FID are:

- fuel gas: hydrogen and air
- make-up gas: nitrogen (recommended) or helium

Detector gases are factory pre-set to:

- 350 mL/min for air
- 35 mL/min for hydrogen
- 30 mL/min for make-up gas

To ensure the correct regulation of detector gases a minimum line pressure of 4 bar (400 kPa, 60 psi) must be provided to the instrument.



NOTE

Usually the air flow is about ten times the hydrogen flow to keep the flame lit.

For high sensitivity applications, it is essential to exclude all traces of organic contamination from the chromatographic system and/or detector gas lines. Such contamination may create ghost peaks in the chromatogram or, more often, an unstable baseline.

FID Installation

This operation allows the correct installation of the FID on your FOCUS GC.

Material required

- Jet for FID
 - Tool for jet
1. Place the jet into the detector base body housing and tighten it with the proper tool. Ensure the jet is perfectly vertically aligned to avoid damaging its ceramic part.

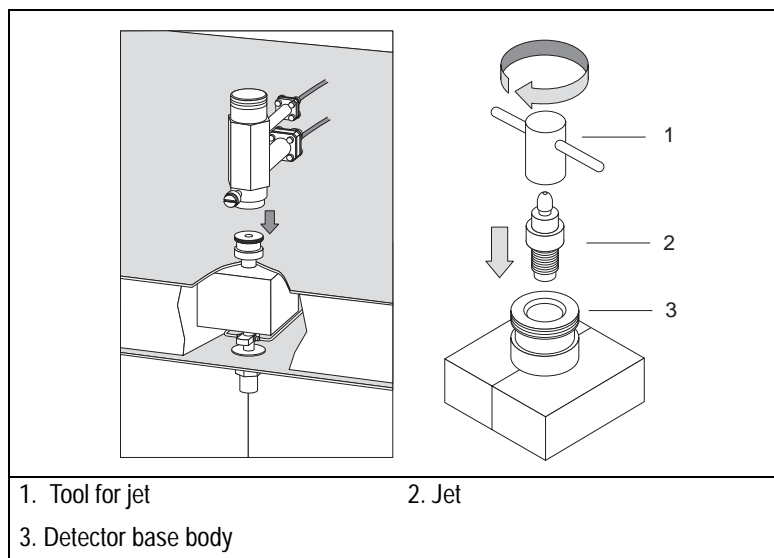

Figure 8-3. Jet for FID

2. Install the FID on the detector base body and secure it by using the fixing screw on the front of the detector cell.
3. Carefully, connect the signal and ignition polarization cables coming from the detector control card, to the detector cell.

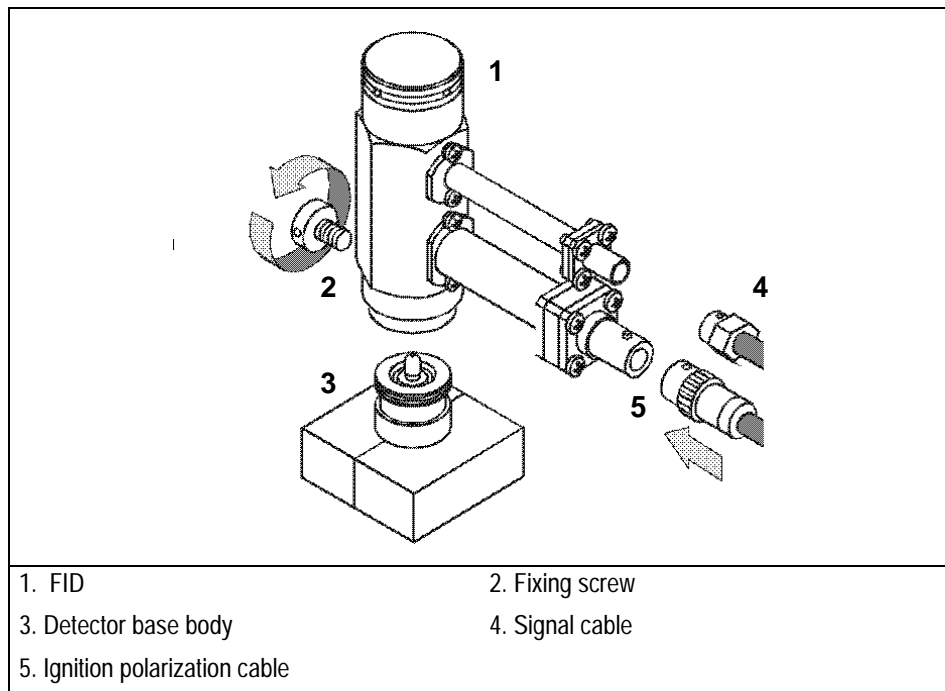

Figure 8-4. Installation of the FID

FID Menu

The **DETECTOR** menu contains the detector control parameters.
In Main Menu, move the cursor until **Detector** is selected. Press **ENTER** to display the **DETECTOR** menu.

DETECTOR (FID)	
Flame	Off
Temp	200 200
Signal pA	(10.0)
Ing. Thresh.	2.0
Flameout retry	Off
H2	On
Air	On
Make-up	Off

Table 8-1. FID Parameters

Parameter	Range	Description
DETECTOR		This line is the title bar
Flame	On –Off	This indicates the flame status: On, Off, Igniting, Waiting or Out. Hydrogen and air flows are required to light the flame. Set On to turn on the flame flows. This happens only if the Temp is 150 °C. If not, an error message is displayed. The Out message is displayed when the flame is inadvertently extinguished. Set Off to turn off the flame flows.
Temp	100 - 375 °C in steps of 1 °C Off	This indicates the detector base body temperature. Set 0 to turn off the heater and display the actual value.

Table 8-1. FID Parameters (Continued)

Parameter	Range	Description
Signal pA	0 - 1000.00 pA Not editable	This parameter shows the collector current in pico amperes (standing current level). The displayed value is also used to indicate the flame status. If the value is very low (such as 0.3 pA), the flame is off. When the value displayed is greater than the Ignition threshold, the flame is on.
Ign. thresh	0 - 999 pA	The FID produces a small signal current when lit. This parameter defines the flame on condition. The FOCUS GC uses this value to determine flame status (on or off) and control automatic re-ignition. If Flameout retry is On, the flame will re-ignite if the signal drops below this value. This line doesn't appear at detector signal range 2 and 3. (Threshold assumes 0 pA).
Flameout retry	On - Off	This indicates re-ignition status. Set On to program when the flame re-ignition should be attempted. Refer to Flame Out Conditions for more information. This line doesn't appear at detector signal range 2 and 3.
H2 Air	On - Off	These indicate the hydrogen and air flow supplied to the detector. You can only turn the flows on and off. Set On to turn on the gas flows. Set Off to turn the flows off.
Make-up	On - Off	This indicates the make-up gas used with the FID. You can only turn the flows On and Off. Set On to turn on the gas flows. Set Off to turn off the flow.

Flame Out Conditions

When the flame is accidentally extinguished, either permanently because of exhausted fuel gas supplies or temporarily, the Flame Out message is displayed in the menu and a message is recorded in the **Run Log**.

If the Retry function is turned On, the system will attempt to re-ignite the flame up to three times.

Detector Signal Parameters

The detector **SIGNAL** menu contains the parameters that control the detector signal. As compounds elute from the column and enter the detector, an electrical signal is generated. The size of the signal is related to the amount of the corresponding compounds. The detector's electronics process the signal and send it to a recording device. The plot of the signal size versus the time results in the chromatogram.

In Main Menu move the cursor until **Signal** is selected. Press **ENTER** to display the **SIGNAL** menu.

SIGNAL	
Output	(1000000)
Offset	100000
Run autozero	On
Range = 10 [^]	(0..3) 0

Table 8-2. FID Signal Parameters

Parameter	Range	Description
SIGNAL		This line is the title bar
Output	Not editable	This is the actual electrometer output signal expressed in gV. The Autozero function forces this value to 1000 corresponding to the zero level of the baseline on a recording device. You cannot enter a setpoint here.
Offset	0 to 100000	This is a value in counts that may be subtracted from the Output signal to adjust the baseline level. This parameter may be manually or automatically set using the Auto zero function. The range of the suppression is variable and related to the output signal.
Run autozero	On - Off	This function forces the output signal to 1000 (zeroing). Set On to zero the detector signal.
Range	10 0 - 10 3 1, 10, 100, 1000 nA	This parameter sets the electrometer amplifier input range. 10 0 are the most sensitive.

OPERATING SEQUENCE

Programming a FID

Materials required:

- bubble flow or electronic flow meter
- detector base body/flow meter adapter

Before you begin this sequence, do the following:

- Verify that all detector gases are connected, a column is correctly installed, and the system is free of leaks.
- Check the oven temperature and injector temperature.
- Check the carrier gas flow depending on the capillary or packed column in use.



WARNING! Hydrogen is a potentially dangerous gas. Refer to Using Hydrogen for safety information.

1. In Main Menu move the cursor until **Detector** is selected. Press **ENTER** to display the **DETECTOR** menu.
2. Set the detector base body temperature. This must be greater than 150 °C to allow the flame ignition.
3. Turn **Hydrogen flow**, **Air flow** and **Make-up gas flow** **On**.
4. When the detector base body is at the set temperature, scroll to **Flame** and set it **On**. This turns on the air and hydrogen flows and initiates the ignition sequence. The signal increases after the ignition. A sudden baseline deflection also indicates that the flame is lit inside the detector. After a few seconds the baseline should stabilize to the standing current level of the system.
5. If desired, in Main Menu move the cursor until **Signal** is selected. Press **ENTER** to open the **SIGNAL** menu and verify the output signal.

6. Refer to *Setting the FID Signal Parameters* operating sequence for instructions on setting the signal parameters.

If you desired to check or modify the detector gas flows operate as follows:

- Set the detector base body temperature **Off**.
- Loosen the fixing screw on the front of the detector cell and remove the detector.
- Turn the air and make-up gas flows **Off**.
- Turn the Hydrogen flow **On**.
- Connect the flow meter to the detector base body using the adapter.
- Measure the gas flow and verify that the flow rate is 35 mL/min.
- By using a screwdriver, adjust the gas flow with the flow regulator until the desired gas flow is achieved.
- Turn the hydrogen flow **Off**.



WARNING! Never measure air and hydrogen flow together.

- Turn the Air supply **On**.
- Measure the gas flow and verify that the flow rate is 350 mL/min.
- By using a screwdriver, adjust the gas pressure with the pressure regulator until the desired gas flow is achieved.
- Turn the Air flow **Off**.
- Turn the Makeup gas flow **On**.
- Measure the gas flow and verify that the flow rate is 30 mL/min.
- By using a screwdriver, adjust the gas flow with the pressure flow until the desired gas flow is achieved.

OPERATING SEQUENCE

Setting the FID Signal Parameters

1. In Main Menu move the cursor until **Signal** is selected. Press **ENTER** to display the **SIGNAL** menu.
2. Scroll to **Range 10[^] (0 . . . 3)** and set the electrometer amplifier input range. The value 0 (10^0) is the most sensitive.
3. Scroll to **Run Autozero** and set **On**.
4. If offset is required, scroll to **Offset** and enter a numeric value or set it **On** to recall the last offset from memory.



NOTE

If the Range 10[^] is set 2 or 3, the small variation of the output signal is not detected. For this reason, the, Signal pA, Ign. thresh and Flameout retry parameters will be not displayed in the **DETECTOR** menu.

Thermal Conductivity Detector (TCD)

This chapter describes the operating principles and sequences for the Thermal Conductivity Detector (TCD).

Chapter at a Glance...

TCD Overview	172
TCD Gas Supplies	174
TCD Operating Modes	175
Selecting TCD Operating Parameters	177
TCD Menu	179
Detector Signal Parameters	181

Operating Sequences

Programming a TCD	182
Setting the TCD Signal Parameters	184
Shutting Down the TCD	185

TCD Overview

The TCD is sensitive to any compound having thermal conductivity other than that of the carrier gas used. The TCD is a universal type detector. It has a broad range of uses in the analysis of permanent gases and other organic or inorganic compounds for which the Flame Ionization Detector (FID) is practically non-sensitive, such as CO₂, CS₂, H₂O, H₂, and N₂.

While the FID is more sensitive to most organics, the simplicity of the TCD often makes it the preferred detector when analyte concentrations are high enough. The TCD typically requires only one type of gas, such as helium. The FID requires up to four.

The TCD consists of a stainless steel block containing two filaments (generally tungsten/rhenium filaments) which have the same electrical resistance. The block is housed in an aluminum case that accommodates the heating elements and the temperature sensor.



TCD with polyimide coated filaments is optionally available for the analysis of very aggressive gas matrices.

The filaments are electrically connected to a Wheatstone bridge. Two gas flows, a reference flow and an analytical flow, enter the TCD cell, pass across the filaments, and vent to the atmosphere. Figure 9-1 shows the filaments and gas flows.

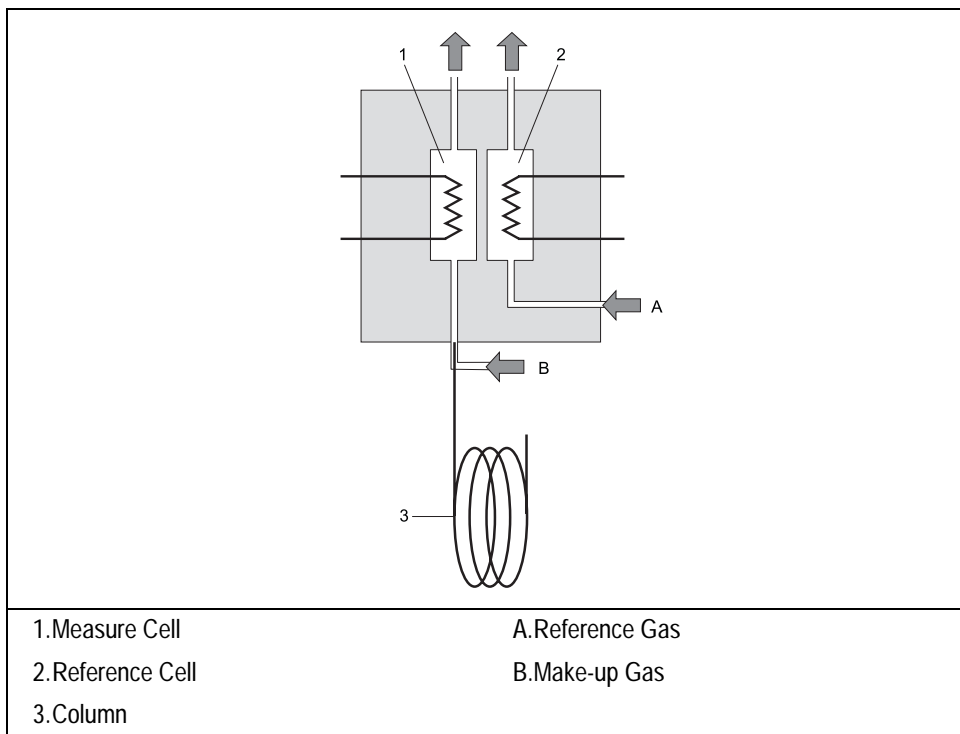

Figure 9-1. TCD Filaments and Gas Flows

When the filaments are properly powered, they heat at a temperature (resistance) that is a function of the thermal conductivity of the gas flowing through the filaments. When a chromatographic component elutes in the analytical channel, a change takes place in the heat transfer followed by a variation of the filament temperature. The signal polarity is a function of the thermal conductivity of the component relative to the reference gas and to the user-selected polarity of the filament power supply.



WARNING! The TCD filaments are sensitive to impurities present in the carrier, reference, and make-up gas supplies. To ensure correct detector operation, you should use oxygen and water vapor traps in the carrier gas and the make-up gas supply lines. We suggest that you install an OXICLEAR filter (PN 281 131 40) before connecting the gas to the GC.

TCD Gas Supplies

The TCD detector requires the same gas whether for the measure channel (carrier plus make-up gas) and the reference channel (reference gas).

Helium is the recommended carrier gas due to its high thermal conductivity and chemical inertness. Low conductivity gases (argon, nitrogen) are used for special analytical requirements. With special precautions, you can also use hydrogen as the carrier and detector gas.



WARNING! Hydrogen is a potentially dangerous gas. Refer to [Using Hydrogen](#) for safety information.

Table 9-1 contains information about the thermal conductivity of several gases.

Table 9-1. Thermal Conductivity of Gases

Gas	Thermal Conductivity ($\lambda \times 10^7$) at 0 °C where $\lambda = \text{Cal/cm} \times \text{sec.} \times \text{°C}$
Hydrogen	4130
Helium	3363
Methane	720
Oxygen	583
Nitrogen	580
Carbon Oxide	540
Argon	406
Carbon Dioxide	343

Detector gas flow rates are factory preset to 30 mL/min for reference and to 27 mL/min for make-up. To modify the detector flow setting refer to Chapter 3.

To ensure the correct regulation of detector gases a minimum line pressure of 4 bar (400 kPa, 60 psi) must be provided to the instrument.



WARNING! The TCD DGFC has a pressure sensor that generates an error signal in case the gas line pressure goes below 1 bar (100 kPa, 14 psi). In this case the TCD filament power is automatically switched off.

Columns

The TCD use two separate gas lines. One connects to the analytical column and the other connects to the reference channel.

The column effluent connects to the analytical cell along with the make-up gas, from the DGFC pneumatic detector module.

When using capillary columns, the make-up line must be activated. This line has to feed the analytical channel at the column outlet, thus compensating the low column flows used with the capillary columns. When using packed columns, the make-up gas is not required and can be kept closed.

For column installation instructions, refer to Chapter 6, [Column](#).

TCD Operating Modes

The TCD can operate in constant temperature or constant voltage mode. It can also automatically switch to a *constant current mode* when the filaments reach the maximum allowable current value of 125 mA.

Constant Temperature

In constant temperature mode, the filament temperature remains constant at a set value. A feedback loop circuit changes the voltage as the gas thermal conductivity changes. If the required voltage reaches the maximum allowable value of 15 V, the system will automatically switch to the *constant voltage mode*.

The CT configuration ensures the maximum linearity of the detector up to concentrations of 1%.

Constant Voltage

In constant voltage mode, the filament voltage remains constant at a set value. The temperature variation, positive or negative, generates a current variation, negative or positive, that will give the corresponding signal. The voltage values range from 5 to 15 V. If the current reaches the maximum allowable value of 125 mA, the system will automatically switch to the *constant current mode*.

When the *constant voltage mode* is used, it is necessary to set the filament

temperature limit in the TCD detector menu (Table 9-4). If this value is reached, the system will automatically switch to the *constant temperature mode*.

The CV mode extends the linearity range to higher values, but with a negative impact on sensitivity.



NOTE

Automatic Switching to Constant Current Mode

Every time the set values of filaments voltage, block temperature and filaments temperature cause the filament current to reach the maximum value of 125 mA, the system will automatically switch to the *constant current mode* and the filaments cannot be heated more than the correspondent temperature.

This mode has good sensitivity and a linearity comparable to that obtained with the CV mode. However, the high filament temperatures can potentially shorten the filament life.

Selecting TCD Operating Parameters

The TCD can be set to operate in constant temperature (CT) and constant voltage (CV) modes.



WARNING! In case of TCD with the polyimide coated filaments, the maximum operating temperature is 300 °C for the TCD cell and 320 °C for the filaments.

Using the CT Mode

For samples in concentrations not exceeding 10%, use the following values:

- detector temperature: 10 °C higher than the maximum column oven temperature reached during the analysis
- filament temperature: 80–100 °C above the detector temperature.

The CT mode provides the highest sensitivity and is suggested for trace analysis (ppm). Since the temperature remains constant, this mode considerably increases the filament life compared to other operating modes.

For samples in concentrations not exceeding 1%, use the following values:

- detector temperature: 10 °C higher than the maximum temperature reached by the column oven during the analysis, but not higher than 300 °C
- filament temperature: 120–150 °C above the detector temperature

Using the CV Mode

For samples in concentrations of a wide percentage range (1–100%), use the following values:

- detector temperature: 10 °C higher than the maximum column oven temperature reached during the analysis
- filament voltage: 5–7 V

In this operating mode, the detector response is linear up to the maximum concentrations.

When using low thermal conductivity gases, the temperatures reached by the filaments are very high. Table 9-2 contains the experimental filament temperature values corresponding to the applied voltages when using argon.

Table 9-2. Filament Temperature Values for Argon

Detector Temperature 100 °C	Values					
Voltage (V)	5	6	7	8	9	10
Filament Temperature (°C)	235	275	315	355	395	435

For samples with a wide range of concentration percentage (1–100%), use the following values:

- detector temperature: 10 °C higher than the maximum temperature reached by the column oven during the analysis, but not higher than 300 °C
- filament voltage: 5 V

Suggested Operating Values

Table 9-3 contains the suggested operating values for the detector as a function of the concentration range and detector temperature.

Table 9-3. Selectable TCD Parameters

Concentration Range	Detector Temperature	Filament Temperature	Filament Voltage	Mode
ppm—5%	100 °C	180 °C	—	CT
0.5–100%	100 °C	—	5 V	CV
ppm—5%	180 °C	270 °C	—	CT
0.5–100%	180 °C	—	6 V	CV
ppm—5%	240 °C	330 °C	—	CT
0.5–100%	240 °C	—	6 V	CV

TCD Menu

The **DETECTOR** menu contains the detector control parameters. In Main Menu, move the cursor until **Detector** is selected. Press **ENTER** to display the **DETECTOR** menu.

DETECTOR (TCD)	DETECTOR (TCD)
Filament power Off	Filament power Off
Fil status (not rdy)	Fil status (not rdy)
Block temp 200 200	Block temp 200 200
Trans temp 200 200	Trans temp 200 200
Cost fill temp?	Cost fill temp? No
Yes	
Fil temp (--) 350	Fil volts (--) 10
Reference On	Fil temp limit 350
Make-up On	Reference On
	Make-up On
Constant Temperature	Constant Voltage

Table 9-4. The Detector (TCD) Parameters

Menu	Range	Comments
DETECTOR (TCD)		This line is the menu title bar.
Filament power ¹	On/Off	Set ON to turn on the filament power. Set OFF to turn off the filament.
Fil status	Ready/ Not Ready	This indicates the filament Ready or Not Ready status.
Block temp	50–370 °C	Set ON to turn on the detector heater and display the actual and setpoint values. Set OFF to turn off the heater.

Table 9-4. The Detector (TCD) Parameters (Continued)

Menu	Range	Comments
Transf temp	50–375 °C	This is the transfer line temperature for the heated zone between the oven and the detector cell. Set ON to turn on the heater and display the actual and setpoint values. Set OFF to turn off the heater. A value between the oven temperature, and the detector temperature must be set. The suggest value is 10 °C lower than the Block temp setpoint.
Const fil temp?	Yes/No	Set YES to activate the constant filament temperature mode and display the Fil temp (CT) parameter. The filament voltage is automatically set to 15V. Set NO to display the filament voltage and maximum filament temperature parameters. The current operating mode (CT, CV, or CC) is displayed in parentheses.
Fil temp (--) ²	On/Off, 50–450 °C	This parameter indicates the filament temperature.
Fil volts (--) ³	5–15 V	This parameter indicates the filament voltage.
Fil temp limit ³⁻⁴	50–450 °C	This parameter indicates the maximum filament temperature.
Ref flow	On/Off,	This parameter indicates the reference gas flow. You can only turn the flow on and off. Set ON to turn on the flow. Set OFF to turn off the flow.
Mkup flow	On/Off,	This parameter indicates the make-up gas flow. You can only turn the flow on and off. Set ON to turn on the flow. Set OFF to turn off the flow.

1. Filament power cannot be turned On if either carrier gas and reference gas are not On.
2. This parameter appears only if the Const fil temp? parameter is set to Yes.
3. This line appears only if Const fil temp? is set to No.
4. When the TCD with the polyimide coated filaments is used, the max temperature is 320 °C

Detector Signal Parameters

The detector **SIGNAL** menu contains the parameters that control the detector signal. In Main Menu move the cursor until **signal** is selected. Press **ENTER** to display the **SIGNAL** menu.

SIGNAL (TCD)	
Output	(5000)
Offset	25000
Run autozero	
Gain	x10
Neg polarity?	No

Table 9-5. TCD Signal Parameters

Parameter	Range	Description
SIGNAL		This line is the title bar
Output ¹	Not editable	This is the actual output signal. The Autozero function forces this value to 1000 corresponding to the zero level of the baseline on a recording device.
Offset	0 to Variable	This is a value in counts that may be subtracted from the Output signal to adjust the baseline level. This parameter may be manually or automatically set using the Autozero function. The range of the suppression is variable and related to the operating conditions.
Run autozero		This function forces the output signal to 1000 (zeroing). Press ENTER to zero the detector signal.
Gain	1, 10	This parameter increases the amplifier gain by a factor of 10.
Neg. polarity?	Yes/No	This parameters allows to reverse the polarity of the signal as a function of the thermal conductivity of the carrier gas.

1. Manual Offset can be entered only if an autozero has been performed before successfully.

OPERATING SEQUENCE

Programming a TCD

When a wide-bore or capillary column is used, the make-up gas line is required.

Materials required:

- bubble flow or electronic flow meter

Before you begin, do the following:

- Verify that all detector gases are connected, a column is correctly installed, and the system is leak free.
- Check the oven temperature and injector temperature.
- Check the carrier gas flow depending on the packed or capillary column in use.
- When a wide-bore or capillary column is used, make sure the make-up gas line is turned **ON**.



WARNING! Hydrogen is a potentially dangerous gas. Refer to Using Hydrogen for safety information.

1. In Main Menu move the cursor until **Detector** is selected. Press **ENTER** to display the **DETECTOR** menu.
2. Adjust and measure the reference gas flow as follows:
 - a. Scroll to **Ref flow** and set **ON**, then adjust the flow rate.
 - b. Adjust the reference flow by operating on the relevant flow regulator
 - c. Measure the flow after stabilization. Repeat this step until the reference gas flow rate is correct.
3. Adjust and measure the make-up gas flow, when required, as follows:
 - a. Scroll to **Mkup flow** and set **ON**, then adjust the flow rate.

- b. Adjust the make-up flow by operating on the relevant flow regulator.
 - c. Measure the flow after stabilization. If necessary, repeat this step until the make-up gas flow rate is correct.
4. Scroll to `Block temp` to enter the detector temperature. Set this temperature to a value 10 °C higher than the maximum oven temperature reached during the analysis.
 5. Scroll to `Transfer temp` and set this temperature to a value equal to the maximum column oven temperature reached during the analysis.
 6. Scroll to `Const fil temp?` to select the operating mode. When constant filament temperature is required, set **YES**; otherwise set **NO**.
 - If **Yes** has been entered, scroll to `Fil temp` and set the filament temperature. This value must always be higher than the detector temperature. The greater the difference between the two temperatures (ΔT), the higher the detector sensitivity.

Set this value depending on the high or low thermal conductivity of the carrier gas in use.

- If **No** has been entered, scroll to `Fil volt` and set the filament voltage.
- Scroll to `Fil temp limit` and set the maximum filament temperature to protect the system. This value must always be higher than the detector temperature.

OPERATING SEQUENCE

Setting the TCD Signal Parameters

1. In Main Menu move the cursor until **Signal** is selected. Press **ENTER** to display the **SIGNAL** menu.
2. Scroll to **Gain** and set the desired value. When the gain is x10, the system sensitivity is higher.
3. If required, scroll to **Neg polarity?** and set **YES** to reverse the polarity output signal as a function of the thermal conductivity of the carrier gas versus the sample.
4. With all gas flows and temperatures adjusted and stable, and with the filaments on and stable, scroll to **Offset** and set **OFF**.
5. Zeroing the Signal.
Every time the set condition of filaments temperature and voltage are changed, an adjustment of the Zero level may be necessary in order to balance the bridge. Usually this operation is performed by scrolling to **Autozero** function and setting **ON**.
In case of a particularly unbalanced bridge, the **Autozero** function may not work and it is necessary to adjust the zero manually as shown in Figure 9-2. Use the little screwdriver, provided in the standard outfit, to adjust the zero potentiometer until a signal of 1000 is visualized.

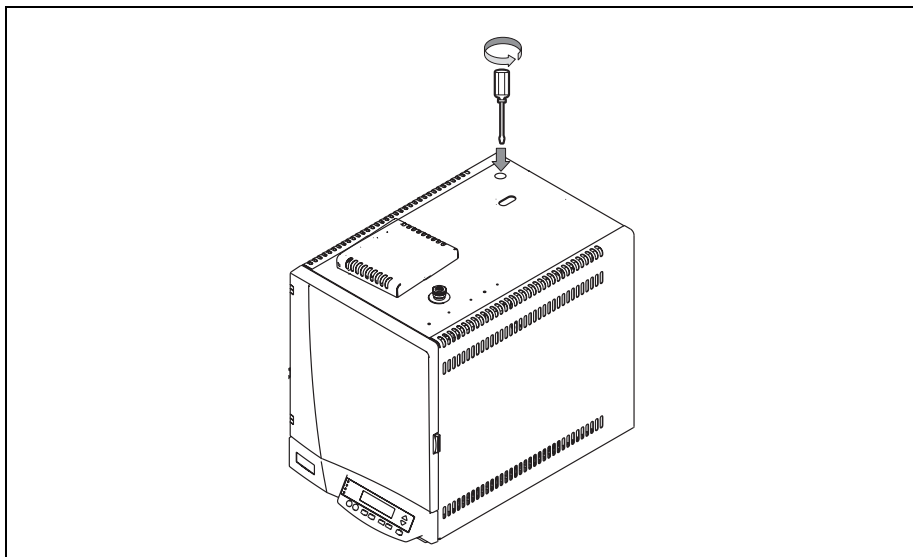

Figure 9-2. Manual Zero-adjustment

OPERATING SEQUENCE

Shutting Down the TCD

At the end of the analytical cycle, the filaments should be turned off.

Autosamplers

This chapter describes how to program and control the AS 2000 autosampler and the AI 3000/AS 3000 by using the FOCUS GC keypad. This chapter contains also the instructions to programming a sample sequence with the FOCUS GC keypad when an AS 2000 or an AI 3000/AS 3000 is used and how to set up ranges of samples to run automatically.



NOTE

TriPlus and HS 2000 autosamplers are controlled only by all the Thermo Fisher Scientific Data Systems referring to the instructions reported in the relevant operating manuals.

Chapter at a Glance...

Autosampler Overview	188
AS 2000 Autosampler Menu	190
AI 3000/AS 3000 Menu	193
Sequence Programming	195

Autosampler Overview

This paragraph contains the instructions to program the AS 2000 and the AI 3000/AS 3000 parameters. The autosampler functions can be controlled through.

AS 2000

- AS 2000 Control Module, referring to the instructions reported in the AS 2000 Autosampler operating manual.
- Thermo Data Systems referring to the instructions reported in the relevant operating manual.
- FOCUS GC keypad, referring to the instructions reported in this chapter.



CAUTION

The autosampler setup involving alignment of the various components must be done from the AS 2000 control module.

AI 3000/AS 3000

- Thermo Data System referring to the instructions reported in the relevant operating manual.
- FOCUS GC keypad, referring to the instructions reported in this chapter.



NOTE

TriPlus and HS 2000 autosamplers are controlled only by all the Thermo Fisher Scientific Data Systems referring to the instructions reported in the relevant operating manuals.

Sequence of Sample

Groups of samples may be automatically run under different analytical conditions programming a *sequence* of samples. A *sequence* describes how samples are treated in the injection stage. The sequence includes the instructions for sampling, number of samples and their position on the sample tray. Refer to paragraph [Sequence Programming](#) for instructions.

Autosampler Configuration

According to the autosampler connected, configure the instrument as described in paragraph *Configuration* on page 51.

Autosampler Menu

In Main Menu move the cursor until **Autosampler** is selected, then press **ENTER** to open **AUTOSAMPLER** menu.

Refer to:

- *AS 2000 Autosampler Menu*
- *AI 3000/AS 3000 Menu.*

AS 2000 Autosampler Menu

This paragraph describes the AS 2000 Autosampler menu.

AUTOSAMPLER	
Sample volume	1.0
Sample rinses	10
Rinse volume	5.0
Injection speed	100
Pre wash solv	A+B
Pre wash cycles	10
Post wash solv	A+B
Post wash cycles	10
Solvent wash vol	5.0
Plunger strokes	10
Viscosity delay	10
Sample draw spd	1
Air gap volume	2
Pre dwell time	10
Post dwell time	10

Table 10-1. AS 2000 Autosampler Menu

Parameter	Range	Description
AUTOSAMPLER		This line is the title bar
Sample volume	0.0–99.9, 100–500 µl	This parameter specifies the amount of sample to be injected for each run.
Sample rinses	0–15 times	This parameter specifies the number of times the syringe is pre-washed with sample.
Rinse volume	0.0–99.9, 100–500 µl	This parameter specifies the amount of sample or solvent pulled for each rinse.
Injection speed	1–100 µl/s, max	This parameter specifies how fast the plunger descends. Use max for speeds over 100 µl/s.

Table 10-1. AS 2000 Autosampler Menu (Continued)

Parameter	Range	Description
Pre wash solv	A, B, C, D,	This parameter specifies the solvent vial used for washing prior the injection.
Pre wash cycles	0–15 times	This parameter specifies the number of times the syringe is pre-washed with solvent.
Post wash solv	A, B, C, D,	This parameter specifies the solvent vial used for washing after the injection.
Post wash cycles	0–15 times	This parameter specifies the number of times the syringe is post-washed with solvent.
Solvent wash vol	depends on syringe volume	This parameter specifies the volume of solvent used to clean the syringe.
Plunger strokes	0–15 times	This parameter specifies the number of plunger strokes to eliminate bubbles.
Viscosity delay	0–15 times	This parameter specifies how long the plunger will remain at the top of the stroke (to account for viscous samples).
Sample draw spd	0 - 100 μ ls	This parameter specifies how quickly the sample is drawn from the vial.
Air gap volume	0.0–99.9, 100–500 μ l	This parameter specifies the amount of air between the solvent, sample, and internal standard for a solvent cleaning injection.
Pre dwell time	0–630 seconds	This parameter specifies how long the needle remains inserted without injecting (<i>hot needle injection</i>).
Post dwell time	0–630 seconds	This parameter specifies how long the needle remains inserted after injection.

If AS 2000 has been configured for internal standard use (see autosampler configuration) an additional line is displayed. See also [Internal Standard Use](#).

AUTOSAMPLER Int Std settings

When you scroll to `Int Std Settings` in the **AUTOSAMPLER** menu and press **ENTER**, the **INTERNAL STANDARD** menu is displayed:

```

INT STD SETTINGS

Int std vial# 20
Int std volume 2.0
Air gap mode double
Air gap volume
```

Table 10-2. Internal Standard Menu

Parameter	Range	Description
INT STD SETTINGS		This line is the title bar
Int std vial#		The tray position of the internal standard vial.
Int std volume		The volume of internal standard or solvent loaded into the syringe.
Air gap mode	Post , double	Select <code>post</code> for a single air gap after the internal standard solution or solvent. Select <code>double</code> for an air gap before and after.
Air gap volume	0.0–99.9, 100–500 µl	The volume of the air between solvent, sample and internal standard for a solvent flush injection.

Internal Standard Use

When you use an internal standard method with the autosampler, you specify a position in the autosampler tray for a vial of internal standard solution. The autosampler then loads a specified volume of the internal standard solution in the syringe before it loads a sample. You can also use the internal standard settings to specify a solvent for a solvent flush injection technique. In this case, a solvent takes the place of the internal standard solution. You can specify an air gap in the syringe between the internal standard solution or the solvent and the sample. This is the *Post air gap* mode. To have an air gap both before and after the internal standard solution or solvent, choose the *Double air gap* mode.

AI 3000/AS 3000 Menu

This paragraph describes the AI 3000/AS 3000 menu.

AUTOSAMPLER	
Sample volume	1.0
Sample rinses	10
Plunger strokes	10
Pre wash solv	A+B
Pre wash cycles	10
Post wash solv	A+B
Post wash cycles	10
Viscous sample	No
Sampl.depth	Bottom
Inj. Depth	Standard
Pre dwell time	10
Post dwell time	10

Table 10-3. AI 3000/AS 3000 Menu

Parameter	Range	Description
AUTOSAMPLER		This line is the title bar
Sample volume	0 to 5 µl with the 10 µl syringe 0 to 2.5 µl with the 5 µl syringe 0 to 250 nl with the 0.5 µl syringe	This parameter specifies the amount of sample to be injected for each run.
Sample rinses	0–15 times	This parameter specifies the number of times the syringe is pre-washed with sample.
Plunger strokes	0–15 times	The number of times the syringe plunger will be pulled up and down to eliminate any bubbles from the sample.

Table 10-3. AI 3000/AS 3000 Menu (Continued)

Parameter	Range	Description
Pre wash solv	A, B, C, D, AB, CD	This parameter specifies the solvent vial used for washing prior the injection.
Pre wash cycles	0–15 times	This parameter specifies the number of times the syringe is pre-washed with solvent.
Post wash solv	A, B, C, D, AB, CD	This parameter specifies the solvent vial used for washing after the injection.
Post wash cycles	0–15 times	This parameter specifies the number of times the syringe is post-washed with solvent.
Viscous sample	No–Yes	Set No for no viscous or low viscous sample. Set Yes for high viscous sample.
Sampl. Depth	Bottom–Center	Set Bottom to pull-up the liquid from the bottom of the sample vial. Set Center from half height of the sample vial
Inj. Depth	Standard–Minimum	It determines the penetration depth of the syringe needle into the vial. When Standard is set (default value) the syringe needle penetrates into the injector up the maximum depth limit (<i>Hot Needle Technique</i>). When Minimum is set, the syringe needle penetrates into the injector up to go beyond the septum only (<i>Cold Needle Technique</i>)
Pre dwell time	0–630 seconds	This parameter specifies how long the needle remains inserted without injecting for a hot needle injection (only in Standard mode)
Post dwell time	0–630 seconds	This parameter specifies how long the needle remains inserted after injection (only in Standard mode).

Sequence Programming

This paragraph contains the instructions to programming a samples sequence with the FOCUS GC keypad when an AS 2000 or an AI 3000/AS 3000 is used and how to set up.



CAUTION The Sequence menu is available in Main Menu only when an autosampler is present.

To access Sequence menu, in Main Menu move the cursor until **Sequence** is selected, then press **ENTER** to open **SEQUENCE** menu.

SEQUENCE	
First sample	1
Last sample	8
Injection/vial	1
When no vial	Skip
Start Sequence	
Stop sequence	

Table 10-4. Sequence Menu

Parameter	Range	Description
SEQUENCE		This line is the title bar
First sample	Depends of the sample tray type.	Enter the position number of the first sample vial of the sequence.
Last sample	Depends of the sample tray type.	Enter the position number of the last sample vial of the sequence.
Injection/vial	1 - 999	Enter the number of times each sample should be run consecutively.

Table 10-4. Sequence Menu (Continued)

Parameter	Range	Description
When no vial	Skip - Abort	When Skip is set, the autosampler skips an eventual missing sample vial and moves to find the next vial. The sample sequence and the sample table of the data system will be not affected. § When Abort is set, the sequence will be aborted after three missing vial
Start sequence		This is visualized when sequence is not running. To start the sequence, select Start sequence , then press ENTER .
Stop sequence		This is visualized when sequence is running. To stop the sequence, select Stop sequence , then press ENTER .

Getting Started

This chapter contains instructions to operate with your FOCUS GC through the instrument keypad. We also included instructions to program a Run Time Events and the instrument start-up.

Chapter at a Glance...

Instrument Set-up	198
Run Time Events	202
Controlling Valves	206
Instrument Start-Up	208
Instrument Status Messages	211

Operating Sequences

How to Set Up the Instrument	198
Editing Run Time Events	202
Deleting a Run Time Event	205
Run Time Control (Gas Sampling Valve Only).....	206
How to Start Up the Instrument.....	208

Instrument Set-up

To set-up your FOCUS GC, perform the operation reported in the following operating sequence:

OPERATING SEQUENCE

How to Set Up the Instrument

FOCUS GC Switching On

Before switching the FOCUS GC On, verify that: the carrier gas supply line is correctly connected to the DPFC module and the inlet pressure is set at the required value as described in Chapter 1.

1. Plug the power cord in the Main socket located on the GC rear panel.
2. Connect the other end of the power cord to the power line.
3. Turn the breaker switch on the position **I**.
4. Wait until the initial routine is completed, then the Main Menu is displayed.

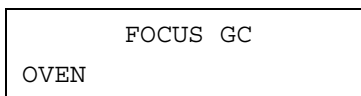

Configure the Carrier Gas

1. In Main Menu move the cursor until **Others** is selected, then press **ENTER**.
2. Scroll to **Configuration** then press **ENTER**.
3. Scroll to **Carrier**, then press **ENTER**.
4. Select the required type of carrier gas by using **INC** and **DEC** keys.
5. Press **HOME** to exit.

Set Carrier parameters

6. Check that the carrier gas type is correct for the analysis.
In Main Menu move the cursor until **Carrier** is selected. Press **ENTER** to open **CARRIER** menu.
7. Select the Carrier Constant Flow or Constant Pressure Mode. Enter the initial Flow or Pressure.
 - If you selected **Constant Flow** mode, enter in the Flow line the desired value. The GC calculates the pressure necessary and adjusts the pressure as necessary to maintain the constant flow.
 - If you selected **Constant Pressure** mode, then in the Pressure (kPa) line enter the desired value.
8. Activate the Gas Saver if required. In the Gas Saver Flow (ml/min) and Gas Saver Time (min) lines the desired values.



When you install a new column, you must perform a column evaluation.

Set Oven Parameters

9. In Main Menu move the cursor until **Oven** is selected. Press **ENTER** to open **OVEN** menu.
10. Set the oven temperature and the Oven program required.

Set S/SL Injector Parameters

11. In Main Menu move the cursor until **Inlet** is selected. Press **ENTER** to open **INLET** menu.
12. Set the required temperature setpoint.
13. Select the Split, Splitless or Surge Splitless operating mode.
14. According to the inlet operating mode selected, a different menu will be displayed. Set the required parameters accordingly.

Set Detector Parameters

15. In Main Menu move the cursor until **Detector** is selected. Press **ENTER** to open **DETECTOR** menu.
16. Set the required temperature and open (On) the detector gases setting the relevant inlet pressure as indicated in Chapter 3.
17. Set all the other detector parameters and ignite the detector.

Set Detector Signal Parameters

18. In Main Menu move the cursor until **signal** is selected. Press **ENTER** to open **SIGNAL** menu.
19. Observe the signal at the display. This is the background offset.
20. Set the electrometer amplifier input signal required.

Configure Autosampler

If an AS 2000 or AI 3000/AS 3000 autosampler is present and properly connected to the GC, proceed as follows:

21. In Main Menu move the cursor until **Others** is selected.
22. Scroll to **Configuration** then press **ENTER**.
23. Scroll to **Autosampler**, then press **ENTER**. The system recognizes which autosampler is present, then the relevant menu will be displayed.
24. Select the required parameters by using **INC** and **DEC** keys.
25. Press **HOME** to exit.

Set Autosampler Parameters

26. In Main Menu move the cursor until **Autosampler** is selected. Press **ENTER** to open **AUTOSAMPLER** menu.

27. Set the autosampler parameters required.

28. Press **HOME** to exit.

Set Sequence Parameters

29. In Main Menu move the cursor until **Sequence** is selected. Press **ENTER** to open **SEQUENCE** menu.

30. Set the sequence parameters required.

31. Press **HOME** to exit.

Set events

To program time events and/or to manually change the state of the inlet valves or external valves please refer to the following paragraphs.

- *Run Time Events*
- *Controlling Valves*

Run Time Events

This option allows you to program events to happen prior to or during a run. The following tables are showing two **RUN TIME EVENTS** menus, one without entries and one with one entry.

```
      RUN TIME EVENTS
<none>
Add run time event
```

Run Time Events menu without
entries

```
      RUN TABLE (1 of 1)
PreRun Det Azero
Add run time event
Clear run time event
```

Run Time Events menu with
one entry

The event shown in the loaded menu concern the detector, it adjusts the detector Range to the lowest sensitivity during the PrepRun step. You can program events like this shown with the **RUN TIME** menu and submenu. Up to 16 events may be programmed.

OPERATING SEQUENCE

Editing Run Time Events

Creating a Run Time Event

Use the following sequence to enter new run time events.

1. In main Menu move the cursor until **Others** is selected, then press **ENTER**. Scroll to **Run time Events**, then press **ENTER** to open **RUN TIME EVENTS** menu.

```

RUN TIME EVENTS

<none>
Add run time event

```

2. Scroll to **Add run time event** and press **ENTER** to open **EDIT EVENT** submenu.

```

EDIT TIME EVENT

Event#1          <none>
Run Time         0.00
Setpoint         off
Next event

```

3. Scroll to **Event**. By using **INC** and **DEC** keys, scroll to the type of event you want to add: none, Det Azero, Det gain, Det N pol, EV#1, EV#2.

**NOTE**

In the case that a gas sampling valve has been configured, the label GSVAlve#1 (or GSVAlve#2) replaces EV#2 (EV#1).

4. Scroll to **Run time**. You may choose between two conditions.
 - Select a time in minutes if you want to activate the event during the Run Time
 - Select PrepRun if you want activates the event during the Prep run.
5. Scroll to **Setpoint** and set the setpoint (x1 or x10) according to the event you have set in the previous line.

Adding a New Event

6. Scroll to **Next event** if you want to edit a new event.
7. Press **ENTER**. A new event may be programmed.

- To program a new event repeat the steps 3, 4 and 5.
For example, If GSValve #1 or GSValve #2 event is selected, the **EDIT EVENTS** menu change as follows:

```
EDIT TIME EVENT
Event#2      GSValve#1
Inject at    1.00
Inject for   0.50
Next event
```

- Scroll to **Next event** if you want to edit a new event.



NOTE

The max number of events is 16.

Run Table

- If other events have not to be programmed, press **HOME** to return **RUN TABLE** menu. It will shows the all the Run time events programmed.

```
RUN TABLE (1 of 2)
PreRun      Det Azero
  1.00 GSValve#1 Inj
Add run time event
Clear run time event
```



NOTE

By pressing ENTER on an event line, the relevant EDIT EVENT menu is open.

OPERATING SEQUENCE

Deleting a Run Time Event

1. In Main Menu move the cursor until **Others** is selected, then press **ENTER**. Scroll to **Run time Events**, then press **ENTER** to open **RUN TIME EVENTS** menu.

```

RUN TABLE (2 of 2)
Clear run time event

```

2. Scroll to **Clear run time event** and press **ENTER** to open **CLEAR TIME EVENT** menu

```

CLEAR EVENTS #1
PreRun      Det Azero
1.00 GSValve#1 Inj
Add run time event
Clear all events

```

3. Scroll to the event line of interest and press **ENTER**. The related event is deleted. For example, delete **Det Autozero**.
4. Press **HOME** to return **RUN TIME EVENTS** menu. The menu will go back to the table Run Table (1 of 1).

```

RUN TABLE (1 of 1)
PreRun Det Azero
Add run time event
Clear run time event

```

Controlling Valves

You can manually open or close valves before a run. You can affect the inlet valves and up to two external valves

Possible valves types for the FOCUS GC and external device are:
Septum purge, Split, External event or Gas sampling

Run Time Control (Gas Sampling Valve Only)

1. Add a new event for `GSValve#1`.
2. Choose the time to inject (in minutes)
3. Choose an injection duration (in minutes)
4. Press **HOME** to exit and check the result in the **RUN TABLE**.

Manual Control

1. In main Menu move the cursor until **Others** is selected, then press **ENTER**. Scroll to **Valves**, then press **ENTER** to open **VALVES** menu.

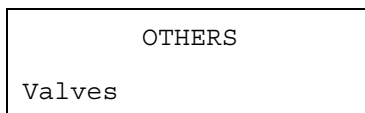

2. Two different menus may be displayed in function of the presence either of an external valve or a gas sampling valve.

VALVES		VALVES	
Split valve	Off	Split valve	Off
Sept purge valve	On	Sept purge valve	On
EV#1	Off	GSSValve#1	Load
EV#2	Off	EV#2	

Valves menu when gas
sampling valve is not present

Valves menu when gas
sampling valve is present

3. To manually open or close valves, scroll on the line of interest and change the valve condition by using **INC** and **DEC** keys. The action has immediate effect.
4. To exit **VALVES** menu press **HOME**.

Instrument Start-Up

This start-up sequence contains the instructions, which combines the analytical procedure with the use of the FOCUS GC program.

OPERATING SEQUENCE

How to Start Up the Instrument

The sequence of instructions begins with the assumption that all the instruments of the system are ON, set and ready to initiate the analyses.

Preliminary Check

Before starting the GC, verify that the following operations have been already carried out:

- The carrier gas supply line is correctly connected to the DPFC module and the inlet pressure is set at the required value as described in Chapter 1.
- The FOCUS GC is properly electrically connected and configured.
- The carrier gas type is correctly set.
- The analytical column is correctly installed and conditioned.
- The correct liner is in the SSL injector.
- The system is free of leak.
- The automatic leak check and column evaluation has been carried out.
- Check the oven temperature and detector temperature.
- Program the carrier gas flow.
- The detector gases inlet pressures are properly set.
- Verify that you have the proper syringe for the technique you are using.
- Program Run time events if required.

Performing a Manual Injection

1. Perform the **Prep Run**, by pressing the **START** button a first time. Depending on the mode you have programmed, the FOCUS GC will perform the following operation.
 - When the gas saver function is programmed, **Prep Run** ends the gas saver mode and resets the split flow to the flow used during the injection.
 - In **Splitless** mode, **Prep Run** closes the split valve and will close the septum purge valve as programmed.
 - In **Surge Splitless** mode, **Prep Run** initiates the surge pressure.
2. When the **Ready to Inject** LED is lit, insert the syringe into the injector, wait for approximately 3 seconds, inject the sample rapidly, and rapidly remove the syringe from the injector (This is the *Hot Empty Needle* technique).
3. Press **START** button.

The GC will complete the analysis as programmed.

Performing Injection Using an Autosampler

Before you begin an autosampler injection, ensure that you have programmed the autosampler method in the **AUTOSAMPLER** menu and the autosampler sequence in **SEQUENCE** menu.

1. Perform the **Prep Run** by pressing the **START** button a first time. Depending on the mode you have programmed, the FOCUS GC will perform the following operation.
 - When the **gas saver** function is programmed, **Prep Run** ends the gas saver mode and resets the split flow to the flow used during the injection.
 - In **Splitless** mode, **Prep Run** closes the split valve and will close the septum purge valve as programmed.
 - In **Surge Splitless** mode, **Prep Run** initiates the surge pressure.

2. In Main Menu, move the cursor until **Sequence** is selected, then press **ENTER**.
3. Scroll to **Start Sequence** and press **ENTER** or **START** button.

The autosampler will inject the samples according to the programmed method and sequence.



NOTE

Pressing the **STATUS** key on the GC keypad, the current instrument status is displayed. For details refer to the paragraph [Instrument Status Messages](#) in this chapter.

Instrument Status Messages

By pressing **STATUS** key, you can visualize the instrument status. According to the current GC operating phase, the following messages may be displayed.

Not Ready

Each message indicates any reasons the GC is in **Not Ready** condition.

```
NOT READY
Oven Temperature
```

```
NOT READY
Equilibrium Time
```

```
NOT READY
Flame out
```

```
NOT READY
Detector temp
```

```
NOT READY
Carrier pressure
```

```
NOT READY
Inlet temp
```

```
NOT READY
Inlet split flow
```

```
NOT READY
Carrier col. flow
```

```
NOT READY
TCD filaments
```

```
NOT READY
TCD block temp
```

Stand-By

The message indicates that the GC is waiting for the Prep run.

```
STAND-BY
Waiting for Prep run
```

If the gas saver function has been selected On in the **Carrier** menu, the following message is displayed.

```
STAND-BY
Gas saver active
```

Prep-Run

This message indicates that the GC performs the events at the Prep Run programmed in **RUN TIME EVENTS** menu.

```
PREP-RUN
Exec Prep-run events
```

Ready to Inject

This message indicates that the GC is waiting for the *Start* signal.

```
READY TO INJECT
Waiting for start
```

Ready to Inject with an Autosampler enabled

This message indicates that autosampler is active and the GC is waiting for the *Start* signal.

```
READY TO INJECT
Autosampler active
Waiting for start
```

Run

These messages indicate the steps of the oven temperature program are currently performed.

```
RUNNING
Initial temperature
```

```
RUNNING
Final temperature 1
```

RUNNING	
Ramp	1

If the Run Log has entries the following message is displayed.

RUNNING	
Run log has entries	

Checkout Using FID with S/SL

This chapter contains the operating procedure to check the Ionization Flame Detector (FID) with the Split/Splitless Injector (S/SL).

Chapter at a Glance...

SOP number: P0407/05/E - 31 May 2006.....	216
Scope	216
Preliminary Operations.....	216
Parts Referenced.....	218
FID-S/SL Checkout in Splitless Mode.....	220

Operating Procedures

FID-S/SL Checkout in Splitless Mode.....	220
--	-----

SOP number: P0407/05/E - 31 May 2006

Scope

The Standard Operating Procedure (SOP) described in this chapter are a series of instructions, operations and test criteria derived from our quality policy procedures used for final testing of the FOCUS GC.

The SOP has been developed to test and verify instrument complete analytical performance after the installation has been completed. This will help you as a guideline, to check if your FOCUS GC continues to perform according to the original checkout testing specifications carried out in the factory premises.

However, these tests alone cannot define if the instrument is not performing according to the original specifications.

The checkout is carried out injecting a standard solution into a test column under analytical conditions set according to the injector and detector hardware provided with the GC. Before starting the test checkout, refer to the Parts Referenced and the Analytical Condition required.



NOTE

Each SOP has a proper Registration and Revision Number (e.g. P0407/01/E - 27 March 2002), according to our Quality Management policy.

Preliminary Operations

Before starting checkout, perform the following preliminary operations sequentially:

1. **Gas Supply Connections**

Connect the gas supplies following the instructions reported in Chapter 4 of the FOCUS GC Site Preparation and Installation Manual

2. **Data Handling Connections**

Connect your data handling following the instructions reported in Chapter 5 of the FOCUS GC Site Preparation and Installation Manual

3. **Glass Liner and Septum Installation**

Install the glass liner following the following instructions reported in the [Installing a Liner and a Septum](#) operating sequence.

4. Column Installation

Install the test column as described in the *How to Connect a Capillary Column* operating sequence following the instructions reported in:

- *Preparing a Capillary Column*
- *Connecting to an S/SL Injector*

5. Column Leak Check

Perform the column leak check following the he instructions reported in the *Manual Checking for Leaks* operating sequence.

6. Column Evaluation

For pressure controlled injector (such as Split/Splitless Injector), the indirect control of the column flow by automatic pressure programming relies on the calculation and pre-determination of a *column constant*. The *column evaluation* is an automatic measurement of the column resistance that determines the *column constant*.



NOTE Column evaluation assumes there are no leaks in the column connection or gas plumbing lines.

Perform column evaluation following the instruction reported in the *Performing a Column Evaluation* operating sequence.

7. Column Conditioning



CAUTION When performing column conditioning, the column should be connected only to the injector leaving the column outlet disconnected to avoid the possibility of contamination of the detector base body.

Column conditioning consists of passing a flow of carrier gas through the column and heating it to a temperature of 20-50 °C above the maximum temperature that will be used for running the analysis. For the test column the working temperature is 350 °C.

8. Detector Connections

This operation should be carried out at the end of the column conditioning. Connect the test column to the detector as described in the *How to Connect a Capillary Column* operating sequence following the instructions reported in:

- [Connecting to a FID Detector](#)

9. Leak Test

This operation should be performed on the system each time the column installation is disturbed, to ensure a good seal throughout the system. Perform the leak test following the instruction reported in the [Performing an Automatic Leak Check](#) operating sequence.

Parts Referenced

Table 12-1. FID-S/SL Parts Referenced

Part	Description	Part Number
Test Column	Fused Silica Capillary Column TR-5; 7 mt long 0.32 mm ID; 0.25 µm film thickness.	260 800 01
Glass Liner	3 mm ID for splitless injection	453 200 32
Liner Seal	Graphite seal for glass liner	290 334 06
Graphite Ferrule	Graphite ferrule for 0.32 mm ID Column	290 134 87
Septum	Standard septum for S/SL injector	313 032 11
Syringe	10 µl size; 50 mm needle length	365 005 25
Test Mixture	Three components in n-Hexane: <i>Component</i> <i>Concentration</i> Dodecane 20 µg/ml Tetradecane 20 µg/ml Hexadecane 20 µg/ml	338 190 20
Gases	Chromatographic-grade purity	
Data Acquisition	Chrom-Card, ChromQuest, Computing-integrator	

Analytical Conditions Required for FID-S/SL

Table 12-2. FID-S/SL Analytical Conditions

Parameters Setting	
Gases	Carrier Gas: Helium = 30 kPa Constant Pressure Hydrogen = 35 mL/min (350 kPa; 50 psi) Air = 350 mL/min (350 kPa; 50 psi) Make-up Gas: Nitrogen = 30 mL/min (350 kPa; 50 psi)
Oven Program	Initial Temperature = 50 °C Initial Time = 1 minute Ramp 1 = 20 °C/minute Final Temperature = 200 °C Final Time = 1 minute
Injector	Operating Mode = Splitless Temperature = 230 °C Splitless Time = 0.8 minutes Split Flow = 60 ml/min Constant Septum Purge = Yes
Detector	Base Temperature = 250 °C Detector Signal Range = 10 ⁰
Injected Volume	1 µl + needle of Test Mixture
Analog Signal Output	Chrom-Card Acquisition Frequency = Medium
Digital Signal Output	Chrom-Card, ChromQuest, Acquisition Frequency = 10 Hz

OPERATING PROCEDURE

FID-S/SL Checkout in Splitless Mode

Before starting, verify the configuration of the carrier and set the checkout required parameters.

Verify Carrier Configuration

- In Main Menu move the cursor until **Others** is selected, then press **ENTER**. Scroll to **Configuration**, then press **ENTER** to open Configuration menu. Scroll to **Configure carrier** submenu then press **ENTER**. Select the carrier gas required by using the **INC** and **DEC** keys.

```

FOCUS GC
Others
  
```

```

OTHERS
Configuration
  
```

```

CONFIGURATION
Carrier
  
```

```

CONFIGURE CARRIER
Gas type      Helium
  
```

- Press **HOME** three times to return Main Menu.

Set Checkout Parameters

- In Main Menu move the cursor until **Carrier** is selected. Press **ENTER** to open **CARRIER** menu.

```

FOCUS GC
Carrier
  
```

4. Scroll to Flow mode and Pressure. By using the **INC** and **DEC** keys select the value or the required operating mode, then press **ENTER**

CARRIER (He)	
Flow mode	Const pres

CARRIER (He)	
Pressure	30.0 30.0

CARRIER (He)	
Col. flow	(3.00) ¹

1. The values in parentheses are not editable

CARRIER (He)	
Gas saver flow	Off

CARRIER (He)	
Vacuum comp.	Off

5. Press **HOME** to return Main Menu.
6. In Main Menu move the cursor until Oven is selected. Press **ENTER** to open **OVEN** menu.

FOCUS GC	
Oven	

7. Scroll to Temp, Initial time, Ramp 1, Final temp 1, Final time 1 and Ramp 2. By using the **INC** and **DEC** keys select the value or the required operating mode, then press **ENTER**.

OVEN	
Temp	50.0 50.0

OVEN	
Initial time	1.00

OVEN		
Ramp 1		20.0

OVEN		
Final temp 1	200	200

OVEN		
Final time 1		1.00

OVEN		
Ramp 2		Off

8. Press **HOME** to return Main Menu.
9. In Main Menu move the cursor until **Inlet** is selected. Press **ENTER** to open **INLET** menu.

FOCUS GC		
Inlet		

10. Scroll to Temp, Mode, Split flow, Total flow, Split flow, Splitless time and Const. Sept purge. By using the **INC** and **DEC** keys select the value or the required operating mode, then press **ENTER**.

Inlet		
Temp	230	230

Inlet		
Mode		Splitless

Inlet		
Total flow		(5.0) ¹

1. The values in parentheses are not editable

Inlet		
Split flow	60.0	60.0

Inlet		
Splitless time		0.80

Inlet		
Const Sept purge		On

11. Press **HOME** to return Main Menu.
12. In Main Menu move the cursor until **Detector** is selected. Press **ENTER** to open **DETECTOR** menu.

FOCUS GC	
Detector	

13. Scroll to **Flame**, **Temp**, **Signal pA**, **Ign. thresh.**, **Flameout**, **retry**, **H2**, **Air** and **Make-up**. By using the **INC** and **DEC** keys select the value or the required operating mode, then press **ENTER**.

DETECTOR (FID)		
Flame		On

DETECTOR (FID)		
Temp	250	250

DETECTOR (FID)		
Signal pA		(5.5) ¹

1. The values in parentheses are not editable.

DETECTOR (FID)		
Ign. thresh.		2

DETECTOR (FID)	
Flameout retry	On

DETECTOR (FID)	
H2	On

DETECTOR (FID)	
Air	On

DETECTOR (FID)	
Make-up	On

14. Press **HOME** to return Main Menu.

15. In Main Menu move the cursor until `Signal` is selected. Press **ENTER** to open **SIGNAL** menu.

FOCUS GC	
Signal	

16. Scroll to `Output`, `Offset`, `Run autozero` and `Range=10^(0..3)`. By using the **INC** and **DEC** keys select the value or the required operating mode, then press **ENTER**.

SIGNAL (FID)	
Output	(1000) ¹

1. The values in parentheses are not editable

SIGNAL (FID)	
Offset	100

SIGNAL (FID)	
Run autozero	

SIGNAL (FID)
Range=10^(0..3) 0

17. Press **HOME** to return Main Menu.
18. Activate your Data System and set the parameters required for the checkout. .
19. In **SIGNAL** menu select Run auto zero, then press **ENTER** to perform the automatic zeroing of the system.

Baseline acquisition and Analysis



NOTE

Refer to the Acceptance Values reported in the Table 12-3 according to the data handling in use.

20. Perform a blank analysis without injecting and press **START** on the GC to begin the checkout run.
21. With the GC in Stand-by/Prep Run condition, activate the data system for 10 minutes to evaluate your baseline in isothermal condition.
22. After the baseline evaluation has been completed, set-up the data system to acquire a single run.
23. Inject the test mixture and press **START** on the GC to begin the checkout run. The resulting chromatogram should look like the one shown in Figure 12-1.

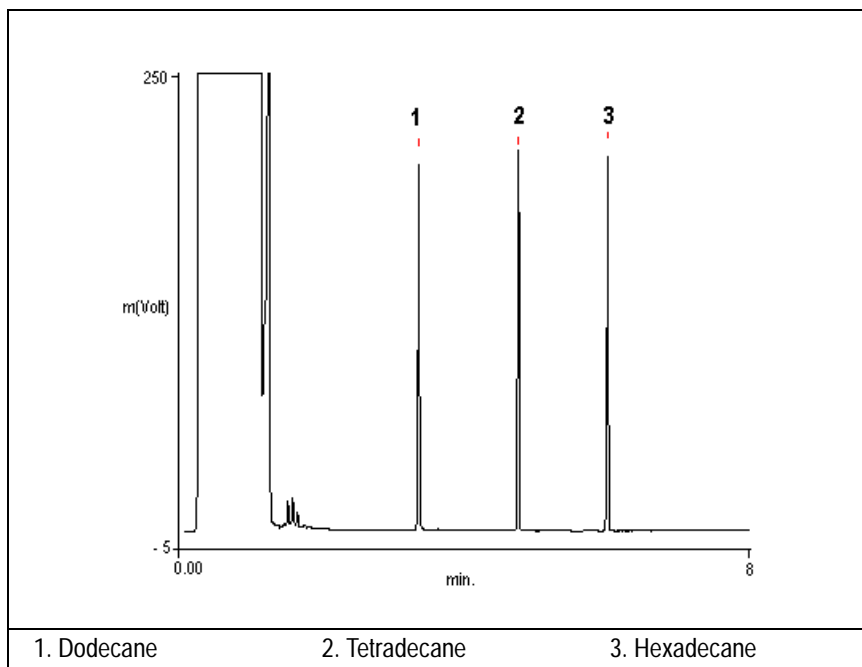





Figure 12-1. FID-Splitless Injection

24. The following criteria indicate successful completion of FID-S/SL checkout.
25. If these criteria are not met, repeat the test.

Table 12-3. FID-S/SL Acceptance Criteria

CHROM-CARD			
Acceptance Values	Baseline Parameters	Analog (1V Full Scale)	Digital (10V Full Scale)
	Noise (μV)	< 30	< 300
	Wander (μV)	< 50	< 500
	Drift ($\mu\text{V}/\text{h}$)	< 100	< 1 000
	Analytical Results	Analog (1V Full Scale) Area Counts (0.1 μVs)	Digital (10V Full Scale) Area Counts (0.1 μVs)
	Components	> 3 400 000 for each component	> 34 000 000 for each component
	Area Count Ratio Calculated as C12/C16	1 ± 0.1	1 ± 0.1
	Using Chrom-Card, connected to the FOCUS GC digital output, refer to Analog or Digital Acceptance Values according to the parameter Signal10Time (0 = analog or 1= digital) set in the Chrom-Card WCC.INI configuration file.		

Computing-integrator (e.g. ChromJet)	
	When a Computing-integrator (e.g. ChromJet) is used, the peak area counts will result to be 5 times lower than the peak area counts obtained by using Analog Chrom-Card .

CHROMQUEST		
Acceptance Values	Baseline Parameters (1V Full Scale)	
	Noise (μV)	< 30
	Wander (μV)	< 50
	Drift ($\mu\text{V}/\text{h}$)	< 100
	Analytical Results (1V Full Scale) - Area Counts (0.01 μVs)	
	Components	> 34 000 000 for each component
	Area Count Ratio Calculated as C12/C16	1 ± 0.1
	Using ChromQuest, connected to the FOCUS GC digital output, and using a range of zero, set in the ChromQuest configuration page, a multiplier of 10^{-8} in V scale (or 10^{-5} in mV scale) in order to have equivalency with FOCUS GC displayed signal output. Different range values need a change of the multiplier used in ChromQuest.	

Analytical Acceptance Comments	
1	When the make-up gas is not used, the acceptance values will result to be 2.5 times lower than the values reported in Table 12-3.
2	When helium is used as make-up gas, the acceptance values will result to be 10 times lower than the values reported in Table 12-3.

Checkout Using TCD with S/SL

This chapter contains the operating procedure to check the Thermal Conductivity Detector (TCD) with the Split/Splitless Injector (S/SL).

Chapter at a Glance...

SOP number: P0473/04/E - 02 May 2007	230
Scope	230
Preliminary Operations.....	230
Parts Referenced.....	232
TCD-S/SL Checkout in Splitless Mode	234

Operating Procedures

TCD-S/SL Checkout in Splitless Mode	234
---	-----

SOP number: P0473/04/E - 02 May 2007

Scope

The Standard Operating Procedure (SOP) described in this chapter are a series of instructions, operations and test criteria derived from our quality policy procedures used for final testing of the FOCUS GC.

The SOP has been developed to test and verify instrument complete analytical performance after the installation has been completed. This will help you as a guideline, to check if your FOCUS GC continues to perform according to the original checkout testing specifications carried out in the factory premises.

However, these tests alone cannot define if the instrument is not performing according to the original specifications.

The checkout is carried out injecting a standard solution into a test column under analytical conditions set according to the injector and detector hardware provided with the GC. Before starting the test checkout, refer to the Parts Referenced and the Analytical Condition required.



NOTE

Each SOP has a proper Registration and Revision Number (e.g. PO407/01/E - 27 March 2002), according to our Quality Management policy.

Preliminary Operations

Before starting checkout, perform the following preliminary operations sequentially:

1. **Gas Supply Connections**

Connect the gas supplies following the instructions reported in Chapter 4 of the FOCUS GC Site Preparation and Installation Manual

2. **Data Handling Connections**

Connect your data handling following the instructions reported in Chapter 5 of the FOCUS GC Site Preparation and Installation Manual

3. **Glass Liner and Septum Installation**

Install the glass liner following the following instructions reported in the *Installing a Liner and a Septum* operating sequence.

4. Column Installation

Install the test column as described in the *How to Connect a Capillary Column* operating sequence following the instructions reported in:

- *Preparing a Capillary Column*
- *Connecting to an S/SL Injector*

5. Column Leak Check

Perform the column leak check following the he instructions reported in the *Manual Checking for Leaks* operating sequence.

6. Column Evaluation

For pressure controlled injector (such as Split/Splitless Injector), the indirect control of the column flow by automatic pressure programming relies on the calculation and pre-determination of a *column constant*. The *column evaluation* is an automatic measurement of the column resistance that determines the *column constant*.



NOTE Column evaluation assumes there are no leaks in the column connection or gas plumbing lines.

Perform column evaluation following the instruction reported in the *Performing a Column Evaluation* operating sequence.

7. Column Conditioning



CAUTION When performing column conditioning, the column should be connected only to the injector leaving the column outlet disconnected to avoid the possibility of contamination of the detector base body.

Column conditioning consists of passing a flow of carrier gas through the column and heating it to a temperature of 20-50 °C above the maximum temperature that will be used for running the analysis. For the test column the working temperature is 350 °C. To perform column conditioning refer to paragraph *Column Conditioning*.

8. Detector Connections

This operation should be carried out at the end of the column conditioning. Connect the test column to the detector as described in the *How to Connect a Capillary Column* operating sequence following the instructions reported in:

- [Connecting to a TCD Detector](#)

9. Leak Test

This operation should be performed on the system each time the column installation is disturbed, to ensure a good seal throughout the system. Perform the leak test following the instruction reported in the [Performing an Automatic Leak Check](#) operating sequence.

Parts Referenced

Table 13-1. TCD-S/SL Parts Referenced

Part	Description	Part Number
Test Column	Fused Silica Capillary Column TR-5; 7 mt long 0.32 mm ID; 0.25 µm film thickness.	260 800 01
Glass Liner	3 mm ID for splitless injection	453 200 32
Liner Seal	Graphite seal for glass liner	290 334 06
Graphite Ferrule	Graphite ferrule for 0.32 mm ID Column	290 134 87
Septum	Standard septum for S/SL injector	313 032 11
Syringe	10 µl size; 50 mm needle length	365 001 03
Test Mixture	Three components in n-Hexane: <i>Component</i> <i>Concentration</i> Dodecane 200 µg/ml Tetradecane 200 µg/ml Hexadecane 200 µg/ml	338 190 16
Gases	Chromatographic-grade purity	
Data Acquisition	Chrom-Card, ChromQuest, Computing-integrator	

Analytical Conditions Required for TCD-S/SL

Table 13-2. TCD-S/SL Analytical Conditions

Parameters Setting	
Gases	Carrier Gas: Helium = 30 kPa Constant Pressure Make-up: Helium = 27.5 ml/min Reference Gas: Helium = 30 ml/min
Oven Program	Initial Temperature = 50 °C Initial Time = 1 minute Ramp 1 = 20 °C/minute Final Temperature = 190 °C Final Time = 1 minute
Injector	Operating Mode = Splitless Temperature = 200 °C Splitless Time = 0.8 minutes Split Flow = 60 ml/min Constant Septum Purge = Yes
Detector	Block Temperature = 200 °C Transfer Temperature = 190 °C Constant Filament Temperature = No Filament Voltage = 10V Filament Temperature limit = 350 °C (*) Gain = x 10 Negative Polarity = No
Injected Volume	1 µl + needle of Test Mixture
Analog Signal Output	Chrom-Card Acquisition Frequency = Medium
Digital Signal Output	Chrom-Card, ChromQuest, Xcalibur Acquisition Frequency = 10 Hz

(*) In case of TCD with the polyimide coated filaments, set the filament temperature limit to 320 °C.

OPERATING PROCEDURE

TCD-S/SL Checkout in Splitless Mode

Before starting, verify the configuration of the carrier and set the checkout required parameters.

Verify Carrier Configuration

1. In Main Menu move the cursor until **Others** is selected, then press **ENTER**. Scroll to **Configuration**, then press **ENTER** to open Configuration menu. Scroll to **Configure carrier** submenu then press **ENTER**. Select the carrier gas required by using the **INC** and **DEC** keys.

```

FOCUS GC
Others
  
```

```

OTHERS
Configuration
  
```

```

CONFIGURATION
Carrier
  
```

```

CONFIGURE CARRIER
Gas type      Helium
  
```

2. Press **HOME** three times to return Main Menu.

Set Checkout Parameters

3. In Main Menu move the cursor until **Carrier** is selected. Press **ENTER** to open **CARRIER** menu.

```

FOCUS GC
Carrier
  
```

4. Scroll to Flow mode and Pressure. By using the **INC** and **DEC** keys select the value or the required operating mode, then press **ENTER**

CARRIER (He)		
Flow mode	Const	pres

CARRIER (He)		
Pressure	30.0	30.0

CARRIER (He)		
Col. flow		(3.00) ¹

1. The values in parentheses are not editable

CARRIER (He)		
Gas saver flow		Off

CARRIER (He)		
Vacuum comp.		Off

5. Press **HOME** to return Main Menu.
6. In Main Menu move the cursor until Oven is selected. Press **ENTER** to open **OVEN** menu.

FOCUS GC	
Oven	

7. Scroll to Temp, Initial time, Ramp 1, Final temp 1, Final time 1 and Ramp 2. By using the **INC** and **DEC** keys select the value or the required operating mode, then press **ENTER**.

OVEN		
Temp	50.0	50.0

OVEN		
Initial time		1.00

OVEN	
Ramp 1	20.0

OVEN	
Final temp 1	190 190

OVEN	
Final time 1	1.00

OVEN	
Ramp 2	Off

8. Press **HOME** to return Main Menu.
9. In Main Menu move the cursor until Inlet is selected. Press **ENTER** to open **INLET** menu.

FOCUS GC	
Inlet	

10. Scroll to Temp, Mode, Split flow, Total flow, Split flow, Splitless time and Const. Sept purge. By using the **INC** and **DEC** keys select the value or the required operating mode, then press **ENTER**.

Inlet	
Temp	200 200

Inlet	
Mode	Splitless

Inlet	
Total flow	(5.0) ¹

1. The values in parentheses are not editable

Inlet		
Split flow	60.0	60.0

Inlet		
Splitless time		0.80

Inlet		
Const Sept purge		On

11. Press **HOME** to return Main Menu.
12. In Main Menu move the cursor until **Detector** is selected. Press **ENTER** to open **DETECTOR** menu.

FOCUS GC	
Detector	

13. Scroll to **Block temp**, **Transf temp**, **Reference**, **Make-up**, **Const fil temp**, **Fil volts (CV)**, **Fil temp limit** and **Filament power**. By using the **INC** and **DEC** keys select the value or the required operating mode, then press **ENTER**.

DETECTOR (TCD)		
Block temp	200	200

DETECTOR (TCD)		
Transf temp	190	190

DETECTOR (TCD)		
Reference		On

DETECTOR (TCD)		
Make-up		On

DETECTOR (TCD)	
Cost fil temp.	N

DETECTOR (TCD)	
Fil volt (CV)	10

DETECTOR (TCD)	
Fil temp limit	350 ¹

1). In case of TCD with the polyimide coated filaments, the temperature limit is 320 °C.

After a few second the ready message is displayed on Fil status line.

DETECTOR (TCD)	
Fil status	ready

14. Press **HOME** to return Main Menu.

15. In Main Menu move the cursor until **Signal** is selected. Press **ENTER** to open **SIGNAL** menu.

FOCUS GC	
Signal	

16. Scroll to **Output**, **Offset**, **Run autozero**, **Gain** and **Neg polarity**. By using the **INC** and **DEC** keys select the value or the required operating mode, then press **ENTER**.

SIGNAL (TCD)	
Output	(1000) ²

2. The values in parentheses are not editable

SIGNAL (TCD)	
Offset	100

SIGNAL (TCD)	
Run autozero	

SIGNAL (TCD)	
Gain (x1..x10)	10

SIGNAL (TCD)	
Neg polarity	N

17. Press **HOME** to return Main Menu.
18. Activate your Data System and set the parameters required for the checkout. .
19. In **SIGNAL** menu select Run auto zero, then press **ENTER** to perform the automatic zeroing of the system.

Baseline acquisition and Analysis



NOTE

Refer to the Acceptance Values reported in the Table 13-3 according to the data handling in use.

20. Perform a blank analysis without injecting and press **START** on the GC to begin the checkout run.
21. With the GC in Stand-by/Prep Run condition, activate the data system for 10 minutes to evaluate your baseline in isothermal condition.
22. After the baseline evaluation has been completed, set-up the data system to acquire a single run.
23. Inject the test mixture and press **START** on the GC to begin the checkout run. The resulting chromatogram should look like the one shown in Figure 13-1.

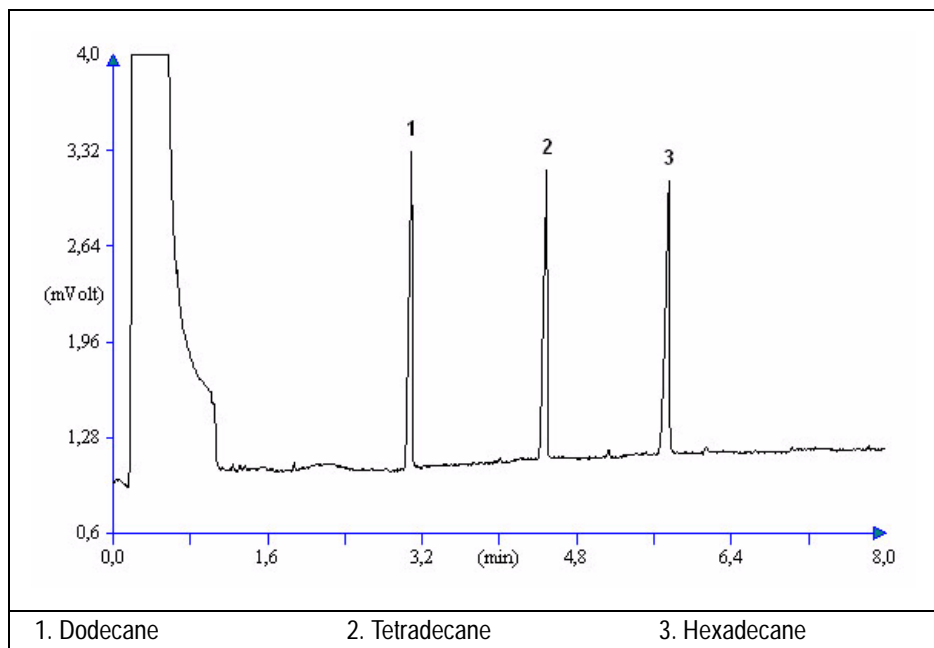



Figure 13-1. TCD-Splitless Injection

24. The following criteria indicate successful completion of TCD-S/SL checkout.
25. If these criteria are not met, repeat the test.

Table 13-3. TCD-S/SL Acceptance Criteria

CHROM-CARD			
Acceptance Values	Baseline Parameters	Analog (1V Full Scale)	Digital (10V Full Scale)
	Noise (μV)	< 30	< 300
	Wander (μV)	< 140	< 1 400
	Drift ($\mu\text{V/h}$)	< 200	< 2 000
	Analytical Results	Analog (1V Full Scale) Area Counts (0.1 μVs)	Digital (10V Full Scale) Area Counts (0.1 μVs)
	Components	> 30 000 for each component	> 300 000 for each component
	Using Chrom-Card, connected to the FOCUS GC digital output, refer to Analog or Digital Acceptance Values according to the parameter Signal10Time (0 = analog or 1= digital) set in Chrom-Card WCC.INI configuration file.		

Computing-integrator (e.g. ChromJet)

	When a Computing-integrator (e.g. ChromJet) is used, the peak area counts will result to be 5 times lower than the peak area counts obtained by using Analog Chrom-Card .
---	--

CHROMQUEST

Acceptance Values	Baseline Parameters (1V Full Scale)	
	Noise (μV)	< 30
	Wander (μV)	< 140
	Drift ($\mu\text{V/h}$)	< 200
	Analytical Results (1V Full Scale) - Area Counts (0.01 μVs)	
	Components	> 300 000 for each component
	Using Chrom-Quest, connected to the FOCUS GC digital output, and using a range of zero, set in the ChromQuest configuration page, a multiplier of 10^{-8} in V scale (or 10^{-5} in mV scale) in order to have equivalency with FOCUS GC displayed signal output. Different range values need a change of the multiplier used in ChromQuest.	

Analytical Acceptance Comments

1	In case of TCD equipped with the polyimide coated filaments, the acceptance values of the Components Area will result to be 4 times lower than the values reported in Table 13-3.
---	---

Checkout Using TCD with PPKD

This chapter contains the operating procedure to check the Thermal Conductivity Detector (TCD) with the Purged Packed Injector (PPKD).

Chapter at a Glance...

SOP number: P0474/05/E - 02 May 2007	244
Scope	244
Preliminary Operations.....	244
Parts Referenced.....	246
TCD-PPKD Checkout	249

Operating Procedures

TCD-PPKD Checkout	249
-------------------------	-----

SOP number: P0474/05/E - 02 May 2007

Scope

The Standard Operating Procedure (SOP) described in this chapter are a series of instructions, operations and test criteria derived from our quality policy procedures used for final testing of the FOCUS GC.

The SOP has been developed to test and verify instrument complete analytical performance after the installation has been completed. This will help you as a guideline, to check if your FOCUS GC continues to perform according to the original checkout testing specifications carried out in the factory premises.

However, these tests alone cannot define if the instrument is not performing according to the original specifications.

The checkout is carried out injecting a standard solution into a test column under analytical conditions set according to the injector and detector hardware provided with the GC. Before starting the test checkout, refer to the Parts Referenced and the Analytical Condition required.



NOTE

Each SOP has a proper Registration and Revision Number (e.g. PO407/01/E - 27 March 2002), according to our Quality Management policy.

Preliminary Operations

Before starting checkout, perform the following preliminary operations sequentially:

1. **Gas Supply Connections**

Connect the gas supplies following the instructions reported in Chapter 4 of the FOCUS GC Site Preparation and Installation Manual

2. **Data Handling Connections**

Connect your data handling following the instructions reported in Chapter 5 of the FOCUS GC Site Preparation and Installation Manual

3. **Glass Liner and Septum Installation**

Install the glass liner following the following instructions reported in the [Installing a Liner and a Septum](#) operating sequence.

4. Column Installation

Install the test column as described in the *How to Connect a Capillary Column* operating sequence following the instructions reported in:

- *Preparing a Capillary Column*
- *Connecting to an PPKD Injector*

5. Column Leak Check

Perform the column leak check following the he instructions reported in the *Manual Checking for Leaks* operating sequence.

6. Column Evaluation

For pressure controlled injector (such as Split/Splitless Injector), the indirect control of the column flow by automatic pressure programming relies on the calculation and pre-determination of a *column constant*. The *column evaluation* is an automatic measurement of the column resistance that determines the *column constant*.



NOTE Column evaluation assumes there are no leaks in the column connection or gas plumbing lines.

Perform column evaluation following the instruction reported in the *Performing a Column Evaluation* operating sequence.

7. Column Conditioning



CAUTION When performing column conditioning, the column should be connected only to the injector leaving the column outlet disconnected to avoid the possibility of contamination of the detector base body.

Column conditioning consists of passing a flow of carrier gas through the column and heating it to a temperature of 20-50 °C above the maximum temperature that will be used for running the analysis. For the test column the working temperature is 350 °C. To perform column conditioning refer to paragraph *Column Conditioning*.

8. Detector Connections

This operation should be carried out at the end of the column conditioning. Connect the test column to the detector following the instructions reported in:

- [How to Connect a Capillary Column](#)
- [Connecting to a TCD Detector](#)

9. Leak Test

This operation should be performed on the system each time the column installation is disturbed, to ensure a good seal throughout the system. Perform the leak test following the instruction reported in the [Performing an Automatic Leak Check](#) operating sequence.

Parts Referenced

Table 14-1. TCD-PPKD Parts Referenced

Part	Description	Part Number
Test Column	Fused Silica Capillary Column TR-5; 7 mt long 0.32 mm ID; 0.25 µm film thickness.	260 800 01
Glass Liner	2 mm ID tapered	453 220 50
Liner Seal	Graphite seal for glass liner	290 334 05
Precolumn	Fused Silica Capillary Column 0.5 mt long 0.53 mm ID	260 603 75
Press-fit connections	For columns 0.53/0.32 mm ID	350 438 16
Injection side adapter	For Wide bore column	347 003 01
Detector side adapter	For Wide bore column	347 103 04
Ferrule	6 mm ID double brass ferrule	290 341 37
Nut	1/4" G-6 mm ID nut	350 201 18
Graphite Ferrule	Graphite ferrule for 0.53 mm ID Column Graphite ferrule for 0.32 mm ID Column	290 134 86 290 134 87
Septum	Standard septum for Purged Packed Injector	313 032 26
Syringe	10 µl size; 51 mm needle length	365 020 01

Table 14-1. TCD-PPKD Parts Referenced (Continued)

Part	Description	Part Number
Test Mixture	Three components in n-Hexane: <i>Component</i> <i>Concentration</i> Dodecane 200 µg/ml Tetradecane 200 µg/ml Hexadecane 200 µg/ml	338 190 16
Gases	Chromatographic-grade purity	
Data Acquisition	Chrom-Card, ChromQuest, Atlas, Xcalibur, Computing-integrator	

Analytical Conditions Required for Splitless Injection

Table 14-2. TCD-PPKD Analytical Conditions

Parameters Setting	
Gases	Carrier Gas: Helium = 30 kPa Constant Pressure Make-up: Helium = 27.5 ml/min Reference Gas: Helium = 30 ml/min
Oven Program	Initial Temperature = 85 °C Initial Time = 1 minute Ramp 1 = 20 °C/minute Final Temperature = 190 °C Final Time = 1 minute
Injector	Operating Mode = Wide bore Septum Purge = Yes Temperature = 180 °C
Detector	Block Temperature = 200 °C Transfer Temperature = 190 °C Constant Filament Temperature = No Filament Voltage = 10V Filament Temperature limit = 320 °C (*) Gain = x 10 Negative Polarity = No
Injected Volume	1 µl + needle of Test Mixture
Analog Signal Output	Chrom-Card Acquisition Frequency = Medium
Digital Signal Output	Chrom-Card, ChromQuest, Atlas, Xcalibur Acquisition Frequency = 10 Hz

(*) In case of TCD with the polyimide coated filaments, set the filament temperature limit to 320 °C.

OPERATING PROCEDURE

TCD-PPKD Checkout

Before starting, verify the configuration of the carrier and set the checkout required parameters.

Verify Carrier Configuration

1. In Main Menu move the cursor until **Others** is selected, then press **ENTER**. Scroll to **Configuration**, then press **ENTER** to open Configuration menu. Scroll to **Configure carrier** submenu then press **ENTER**. Select the carrier gas required by using the **INC** and **DEC** keys.

```
FOCUS GC
Others
```

```
OTHERS
Configuration
```

```
CONFIGURATION
Carrier
```

```
CONFIGURE CARRIER
Gas type           Helium
```

2. Press **HOME** three times to return Main Menu.

Set Checkout Parameters

3. In Main Menu move the cursor until **Carrier** is selected. Press **ENTER** to open **CARRIER** menu.

```
FOCUS GC
Carrier
```

4. Scroll to Flow mode and Pressure. By using the **INC** and **DEC** keys select the value or the required operating mode, then press **ENTER**

CARRIER (He)		
Flow mode	Const	pres

CARRIER (He)		
Pressure	30.0	30.0

CARRIER (He)		
Col. flow	(3.00)	¹

1. The values in parentheses are not editable

CARRIER (He)		
Gas saver flow		Off

CARRIER (He)		
Vacuum comp.		Off

5. Press **HOME** to return Main Menu.
6. In Main Menu move the cursor until Oven is selected. Press **ENTER** to open **OVEN** menu.

FOCUS GC	
Oven	

7. Scroll to Temp, Initial time, Ramp 1, Final temp 1, Final time 1 and Ramp 2. By using the **INC** and **DEC** keys select the value or the required operating mode, then press **ENTER**.

OVEN		
Temp	50.0	50.0

OVEN		
Initial time		1.00

OVEN		
Ramp 1		20.0

OVEN		
Final temp 1	200	200

OVEN		
Final time 1		1.00

OVEN		
Ramp 2		Off

8. Press **HOME** to return Main Menu.
9. In Main Menu move the cursor until **Inlet** is selected. Press **ENTER** to open **INLET** menu.

FOCUS GC		
Inlet		

10. Scroll to **Temp, Mode and Const . Sept purge**. By using the **INC** and **DEC** keys select the value or the required operating mode, then press **ENTER**.

Inlet		
Temp	180	180

Inlet		
Mode		Wide bore

Inlet		
Const Sept purge		On

11. Press **HOME** to return Main Menu.

12. In Main Menu move the cursor until `Detector` is selected. Press **ENTER** to open **DETECTOR** menu.

FOCUS GC	
Detector	

13. Scroll to `Block temp`, `Transf temp`, `Reference`, `Make-up`, `Const fil temp`, `Fil volts (CV)`, `Fil temp limit` and `Filament power`. By using the **INC** and **DEC** keys select the value or the required operating mode, then press **ENTER**.

DETECTOR (TCD)	
Block temp	200 200

DETECTOR (TCD)	
Transf temp	190 190

DETECTOR (TCD)	
Reference	On

DETECTOR (TCD)	
Make-up	On

DETECTOR (TCD)	
Cost fil temp.	N

DETECTOR (TCD)	
Fil volt (CV)	10

DETECTOR (TCD)	
Fil temp limit	350 ¹

- 1). In case of TCD with the polyimide coated filaments, the temperature limit is 320 °C.

After a few second the ready message is displayed on Fil status line.

DETECTOR (TCD)	
Fil status	ready

14. Press **HOME** to return Main Menu.

15. In Main Menu move the cursor until Signal is selected. Press **ENTER** to open **SIGNAL** menu.

FOCUS GC	
Signal	

16. Scroll to Output, Offset, Run autozero, Gain and Neg polarity. By using the **INC** and **DEC** keys select the value or the required operating mode, then press **ENTER**.

SIGNAL (TCD)	
Output	(1000) ²

2. The values in parentheses are not editable

SIGNAL (TCD)	
Offset	100

SIGNAL (TCD)	
Run autozero	

SIGNAL (TCD)	
Gain (x1..x10)	10

SIGNAL (TCD)	
Neg polarity	N

17. Press **HOME** to return Main Menu.

18. Activate your Data System and set the parameters required for the checkout. .

19. In **SIGNAL** menu select Run auto zero, then press **ENTER** to perform the automatic zeroing of the system.

Baseline acquisition and Analysis



NOTE

Refer to the Acceptance Values reported in the Table 14-3 according to the data handling in use.

20. Perform a blank analysis without injecting and press **START** on the GC to begin the checkout run.
21. With the GC in Stand-by/Prep Run condition, activate the data system for 10 minutes to evaluate your baseline in isothermal condition.
22. After the baseline evaluation has been completed, set-up the data system to acquire a single run.
23. Inject the test mixture and press **START** on the GC to begin the checkout run. The resulting chromatogram should look like the one shown in Figure 14-1.

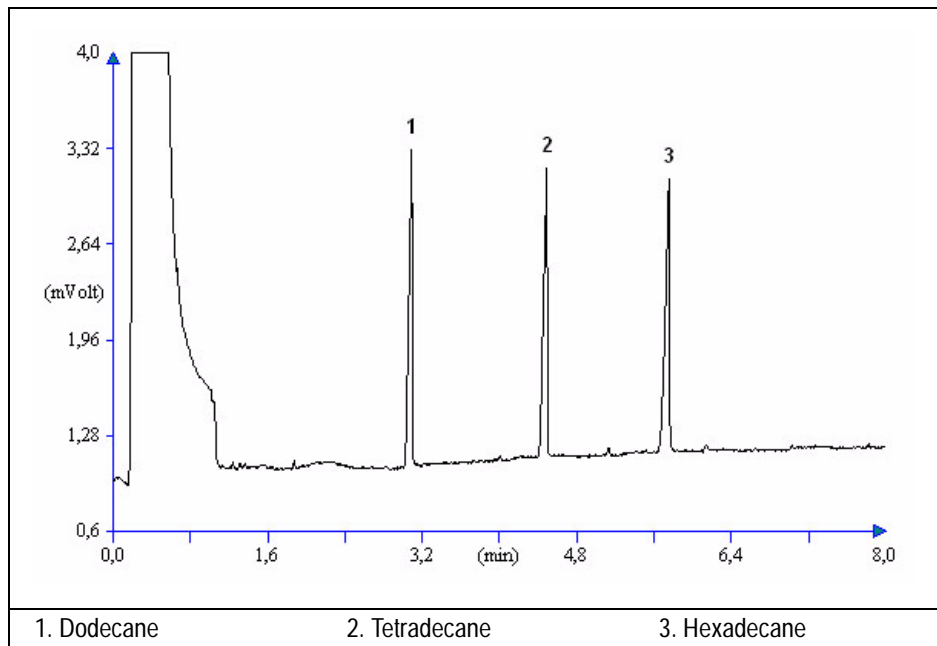



Figure 14-1. TCD-PPKD Injection

- 24. The following criteria indicate successful completion of TCD-PPKD checkout.
- 25. If these criteria are not met, repeat the test.

Table 14-3. TCD-PPKD Acceptance Criteria

CHROM-CARD			
Acceptance Values	Baseline Parameters	Analog (1V Full Scale)	Digital (10V Full Scale)
	Noise (μV)	< 30	< 300
	Wander (μV)	< 140	< 1 400
	Drift ($\mu\text{V/h}$)	< 200	< 2 000
	Analytical Results	Analog (1V Full Scale) Area Counts (0.1 μVs)	Digital (10V Full Scale) Area Counts (0.1 μVs)
	Components	> 30 000 for each component	> 300 000 for each component
	Using Chrom-Card, connected to the FOCUS GC digital output, refer to Analog or Digital Acceptance Values according to the TRACE Signal Time (0 or 1) set in Chrom-Card WCC.INI Configuration.		

Computing-integrator (e.g. ChromJet)

	When a Computing-integrator (e.g. ChromJet) is used, the peak area counts will result to be 5 times lower than the peak area counts obtained by using Analog Chrom-Card .
---	--

CHROMQUEST		
Acceptance Values	Baseline Parameters (1V Full Scale)	
	Noise (μV)	< 30
	Wander (μV)	< 140
	Drift ($\mu\text{V/h}$)	< 200
	Analytical Results (1V Full Scale) - Area Counts (0.01 μVs)	
	Components	> 300 000 for each component
	Using Chrom-Quest, connected to the FOCUS GC digital output, and using a range of zero, set in the ChromQuest configuration page, a multiplier of 10^{-8} in V scale (or 10^{-5} in mV scale) in order to have equivalency with FOCUS GC displayed signal output. Different range values need a change of the multiplier used in ChromQuest.	

Analytical Acceptance Comments

1	In case of TCD equipped with the polyimide coated filaments, the acceptance values of the Components Area will result to be 4 times lower than the values reported in Table 14-3.
---	---

Maintenance and Troubleshooting

This chapter contains information and operating sequences to perform the necessary maintenance of the instrument and also information concerning troubleshooting in case of malfunctioning.

Chapter at a Glance...

Maintenance	259
Maintaining a SSL Injector	262
Maintaining a PPKD Injector	276
Maintaining a FID	282
FID Troubleshooting	295
Maintaining a TCD.....	298
TCD Troubleshooting.....	300
Maintaining Gas Sampling Valve.....	304
Analytical Troubleshooting	306
Error Messages	307
Guide to Solve Analytical Problems	309

Operating Procedures

Replace the S/SL Standard Septum.....	264
Replace or Clean the Liner when a S/SL Standard Septum is Installed.....	267
Replace the S/SL Inlet Vent Line Filter.....	273
Replace the PPKD Septum.....	277
Replace or Clean the PPKD Liner.....	279

Clean/Replace the FID Jet.....	284
Clean/Replace the FID Collecting Electrode	288
Replace the FID Ignition Assembly.....	292
How to Install/Replace the Loop of an Automatic Valve	304

Maintenance

This paragraph provides information on the maintenance of the instrument. It also contains the instructions for the instrument shutdown.

How To Perform Maintenance

Thermo Fisher Scientific authorized technical personnel under the instrument warranty or, when this has expired, possibly under a Service Contract Program will normally perform full instrument servicing.

To ensure that your FOCUS GC always performs to its full potential, the operator must carry out a certain amount of routine maintenance on a regular basis.

Suggested Maintenance Schedule

Preventive maintenance keeps your instruments running at peak performance. The recommended maintenance schedule, shown in the [Maintenance Schedule Table](#), is based on a GC running multiple samples in an 8-hour day. You may need to adapt the schedule to your situation depending on:

- The number of analyses per day
- How clean the samples are
- The condition of the syringe needle
- Environmental conditions such as dirt and ambient temperature

Septa

Septa degrade over time. Different types will degrade at varying rates. Factors affecting septa life include:

- Number of samples injected
- Injector temperature
- Condition of the syringe needle

Ferrules and Seals

Ferrules and seals should be replaced when they are too flat to produce a good seal.



NOTE

Unless required applications necessitate frequent dismantling and replacement of columns and accessories, seals and ferrules normally need to be disturbed only when dismantling is required. However, the FOCUS GC should be periodically leak-tested and the seal tightened or replaced as necessary.

Traps

Internal and external traps in the gas line must be periodically serviced. It is advisable to check the state of the traps every time gas cylinder is replaced..

Detector Unit

To ensure optimum performance of the detector, it must be kept clean and free from dust and deposit. Symptoms such as reduced sensitivity, increased noise and difficulty in flame ignition indicate that detector cleaning may be necessary

Make sure you not only perform each scheduled item, but that you record it as well, along with any observation about instrument performance. Your records and notes can be invaluable when trying to trace a service problem. In addition to the routine and preventive maintenance that you perform, we recommend annual inspections by Thermo Fisher Scientific customer service engineers. These yearly checkups ensure that your instrument remains in peak condition.

Maintenance Schedule Table

Table 15-1. Standard Maintenance Schedule

Frequency	Task
Daily	<p>Run Automatic Leak Test.</p> <p>Run performance check standard as required by method.</p> <p>Run calibration curve as required by method.</p> <p>Note gas pressure when the weekly pressure check shows it to be below 5000 kPa (50 bar or 750 psig).</p>

Table 15-1. Standard Maintenance Schedule

Weekly	Change injector liner. Check pressure of gas cylinders. Replace the cylinder when its pressure drops below 3500 kPa (35 bar or 500 psi).
Monthly	Check for leaks from the primary gas supply to the GC.
Semiannually	Replace the S/SL inlet vent line filter. Replace FID jet. Recondition or replace internal and external traps.
Annually	Clean FID collector.

Instrument Cleaning



WARNING! Cleaning must be performed with the instrument off and the power cord disconnected.

Normal usage of the FOCUS GC can cause the exterior to get dirty.

Externally clean the instrument with a cloth dampened with soap and water solution, or with a household non-abrasive product, carefully avoid seeping of the products used inside the instrument.

If you just suspect that a substance used for cleaning or a product submitted to analysis has infiltrated inside the instrument, immediately shut down the instrument and call an authorized customer support engineer for proper actions. The service engineer must be fully informed on the nature of the concerned substance. In the event that a hazardous material is spilled on or in the instrument, clean the spill according to the procedures in the Material Data Sheet for that substance.



WARNING! It is your responsibility to avoid that dangerous liquids and/or materials seeping inside the GC during operation and maintenance.

Maintaining a SSL Injector

The S/SL (Split/Splitless) injector will normally be serviced by Thermo Fisher Scientific authorized technical personnel. In order to operate at peak performances, the injector requires periodic maintenance from the user. This maintenance includes:

- The replacement of the standard septum
- The maintenance of the Merlin Microseal Valve when used instead of the standard septum
- The cleaning or replacement of the liner
- The replacement of the carbon filter from the DPFC control module.

When Replacing the Standard Septum

The septum should be replaced at least after every 200 injections, or every time a problem related to septum damage or wear occurs.

It is a good practice to change the septum with a new one every time the liner is replaced.



CAUTION

Use original Thermo Fisher Scientific standard septum. Septa from other manufacturers may show different rates of degradation.

When Cleaning or Replacing the Liner

The liner must be replaced periodically, depending on the number of injections performed and the characteristics of the samples injected. Typical symptoms will indicate that the liner must be replaced. The most common is the appearance of tailing peaks in the chromatogram, particularly for polar compounds.

It is good practice to replace the septum every time the liner is replaced.

You can replace the liner with a new one or clean the liner and reinstall it.

The following table shows the available types of liners and the indications for the correct choice.

Liner	PN
Split injections, 3 mm	453 200 31
Split injections, 5 mm	453 200 30
Splitless injections, 3 mm	453 200 32
Splitless injections, 5 mm	453 200 33
Liner for direct injections into wide bore column	453 003 10
Laminar cup liner for split injections at high split flow rates or for the most polar solvents.	453 003 20

If the Glass Liner Breaks Inside the Injector

When replacing or removing a glass liner, it might break inside the injector. In this case the broken parts of the liner must be removed from the injector, including the glass splinters that might fall into the lower part of the vaporization chamber. Refer to [Removing a Broken Liner](#) for instructions.

Related Operating Sequences

The following operating sequences help you to maintain properly the SSL injector.

- [Replace the S/SL Standard Septum](#)
- [Replace or Clean the Liner when a S/SL Standard Septum is Installed](#)
- [Replace the S/SL Inlet Vent Line Filter](#)



NOTE

To replace a standard septum with the Microseal Valve, refer to the relevant Installation Guide.

OPERATING SEQUENCE

Replace the S/SL Standard Septum

Material needed

- Non metallic sharp tool
- Septum
- Tweezers



WARNING! This operation must be carrier out at low temperature to avoid burns. Therefore, before beginning the sequence, the injector must be cooled to room temperature.

Preliminary Operations

1. While in Standby condition, in **OVEN** menu set the oven temperature to 30 °C.
2. In **INLET** menu set the inlet temperature to 0 (0 = Off).
3. When the inlet reaches the room temperature, enter in **CARRIER** menu, scroll to Pressure and set it to 0 (0 = Off).

OVEN		
Temp	30	30

INLET		
Temp	25	Off

CARRIER		
Pressure	0	Off

Removing the Septum

4. Unscrew the septum cap.
5. Remove the septum holder with septum, then the septum support. See A of Figure 15-1.
6. Remove the septum from the septum holder (use non-metallic tools). See B of Figure 15-1.
7. Insert a new septum into the septum holder paying attention that the center guide of the septum must be turned upward. See B of Figure 15-1.



CAUTION Use tweezers to avoid touching the septum with your fingers.

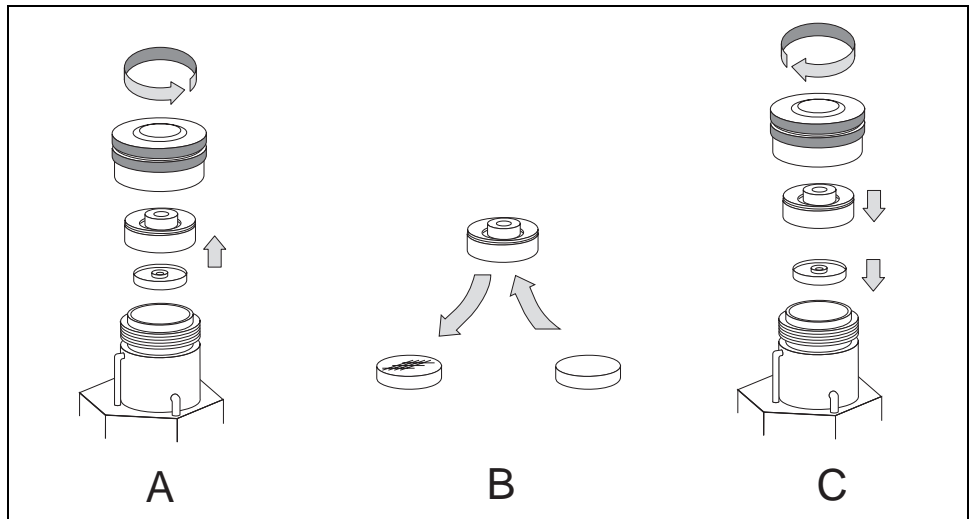

Figure 15-1. Replace the Septum

Replacing the Septum

8. Clean the septum support from possible fragments left by the septum and reinsert it into the injector.

9. Place the septum holder on the top of the septum support (see C of Figure 15-1).
10. Tighten the injector cap to finger tight.



CAUTION

Do not overtighten the injector cap. You could damage the septum and affect performance.

Restart the GC Conditions

11. In **CARRIER**, **OVEN** and **INLET** menus set the normal working conditions.
12. Perform an automatic leak check.

OPERATING SEQUENCE

Replace or Clean the Liner when a S/SL Standard Septum is Installed

Material needed

- Liner cap removal tool
- Glass liner
- Graphite seal
- Ultrasonic bath
- Methanol/acetone mixture (1:1)
- Non metallic sharp tool
- Standard Septum
- Tweezers



WARNING! This operation must be carrier out at low temperature to avoid burns. Therefore, before beginning the sequence, the injector must be cooled to room temperature. When handling organics solvents you must take precautions to avoid health hazards.

Preliminary Operations

1. While in Standby condition, in **OVEN** menu set the oven temperature to 30 °C.
2. In **INLET** menu set the inlet temperature to 0 (0 = Off).
3. When the inlet reaches the room temperature, enter in **CARRIER** menu, scroll to Pressure and set it to 0 (0 = Off).

OVEN		
Temp	30	30

INLET		
Temp	25	Off

CARRIER		
Pressure	0	Off

Removing the Septum

4. Unscrew the septum cap.
5. Remove the septum holder with septum, then the septum support. See A of Figure 15-2.

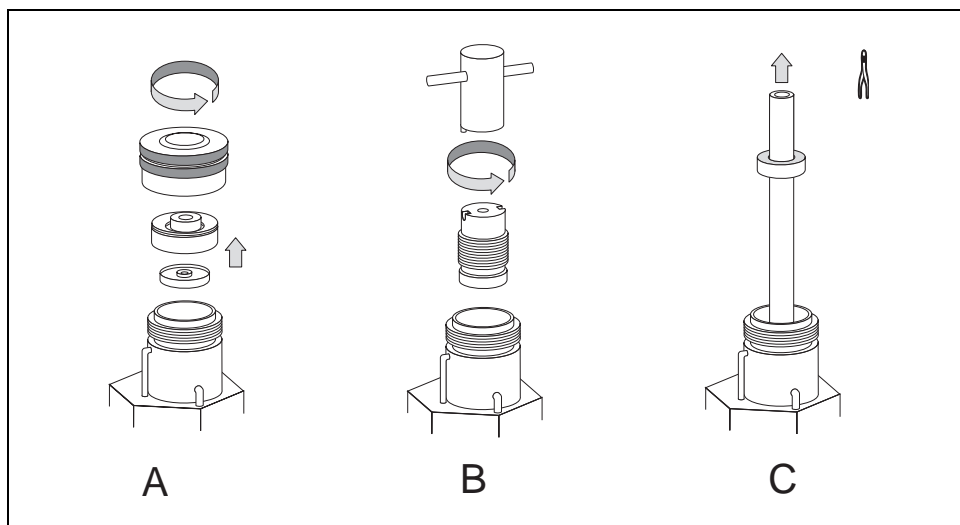

Figure 15-2. Replace and Clean the Liner (1)

6. Use the liner cap wrench provided with the GC to remove the injector liner cap. See B of Figure 15-2.

7. Use tweezers to remove the liner with the graphite seal. See C of Figure 15-2.



CAUTION Be careful not to break the glass liner inside the injector when removing it. Glass splinters might fall into the lower part of the vaporization chamber. If the liner breaks, refer to [Removing a Broken Liner](#).

- If you are going to use a new liner, go to the step [Cleaning the liner](#) then continue from the step [Replacing the Liner](#).
- If you are going to clean the liner go to step [Cleaning the liner](#) then continue from the step [Replacing the Liner](#).
- If you are going to remove a broken liner go to step [Removing a Broken Liner](#) then continue from the step [Replacing the Liner](#).

Cleaning the liner

- a. Put the dirty liner into an ultrasonic bath filled with a methanol/acetone mixture (1:1) and sonicate it for about half an hour.
- b. Using tweezers, remove the liner from the bath and dry it with compressed clean air.



NOTE

For trace analysis, you should pre-treat the liner with a suitable silylating reagent prior to re-inserting it into the injector.

Removing a Broken Liner

- a. Unscrew the nut that retains the analytical column, then move the analytical column with its ferrule. See D of Figure 15-3.
- b. Unscrew the retaining nut at the bottom of the injector, then remove the terminal fitting with its silver seal. See E of Figure 15-3.



CAUTION Glass splinters from the broken liner will fall from the injector.

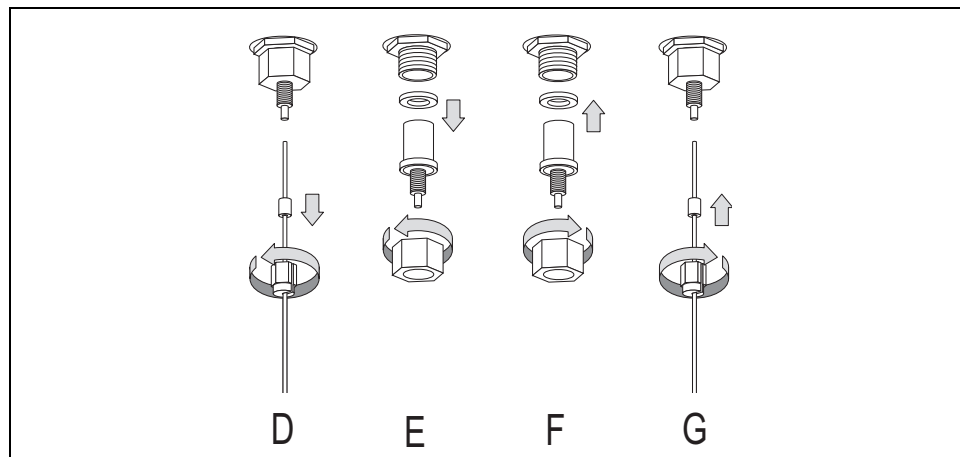

Figure 15-3. Replace a Broken Liner

- c. With the aid of a pipe cleaner, remove the possible glass fragments from the vaporization chamber.
- d. Reinsert the silver seal and the terminal fitting, and then tighten the nut that retains the terminal fitting. See F of Figure 15-3.
- e. Insert the analytical column with its ferrule into the bottom of the injector in its previous position, then tighten the M4 retaining nut to hold the column in place. See G of Figure 15-3.

Replacing the Liner

8. Holding the new (or cleaned) liner with tweezers, place a graphite seal over the liner, making sure to leave a distance of about 10 mm between the seal and the liner end.
9. Using tweezers, insert the liner into the injector and push it gently towards the bottom fitting. See D of Figure 15-4.

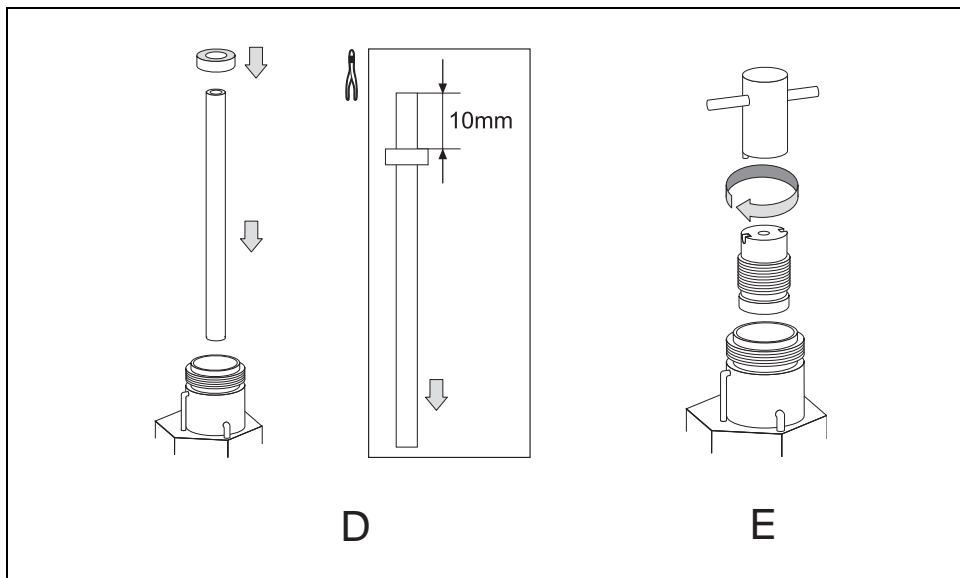

Figure 15-4. Replace and Clean the Liner (2)

CAUTION Make sure you insert the beveled end of the liner towards the bottom of the injector. Be careful not to damage the graphite seal or allow graphite to enter the liner. Should this occur, clean the liner with an inert gas.

10. Tighten the liner cap using the liner cap wrench provided with the GC. See E of Figure 15-4.
11. Remove the septum from the septum holder (use non-metallic tools).
12. Insert a new septum into the septum holder paying attention that the center guide of the septum must be turned upward. See F of Figure 15-5.



CAUTION Use tweezers to avoid touching the septum with your fingers.

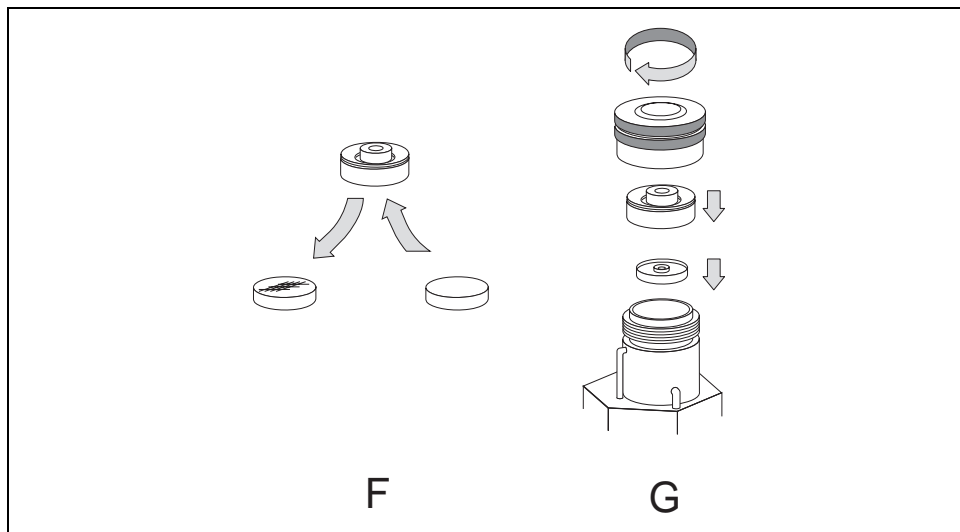

Figure 15-5. Replace and Clean the Liner (3)

13. Clean the septum support from possible fragments left by the septum and reinsert it into the injector.
14. Place the septum holder on the top of the septum support (see G of Figure 15-5).
15. Tighten the injector cap to finger tight.

CAUTION Do not overtighten the injector cap. You could damage the septum and affect performance.

Restart the GC Conditions

16. In **CARRIER**, **OVEN** and **INLET** menus set the normal working conditions.
17. Perform an automatic leak check.

OPERATING SEQUENCE

Replace the S/SL Inlet Vent Line Filter

This carbon filter is mounted on the DPFC module located on the rear of the GC. To replace the filter operate as follows:



WARNING! Before operating the FOCUS GC MUST BE SWITCHED OFF.

Remove the FOCUS GC Top Cover

The top cover is fixed on the main unit with two front screws and two clips.

1. Open the GC oven door.
2. Unscrew the two front screws, as shown in Figure 15-6, which remain on the main unit.
3. Remove manually the top cover pulling it up from the front, the two clips will be automatically unlocked.

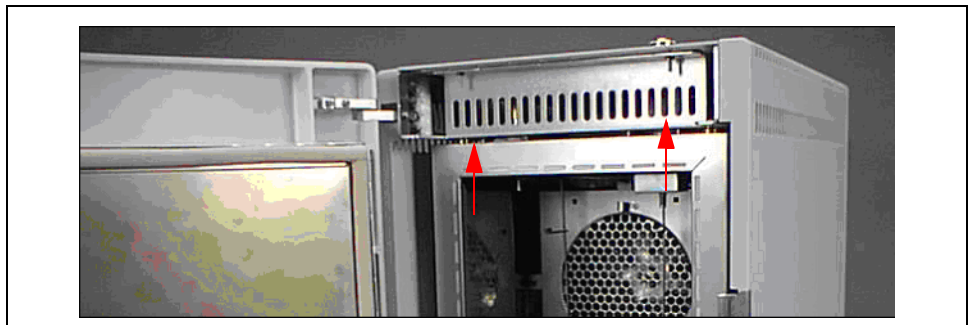

Figure 15-6. Top Aluminium Cover Removal (1)

Remove the FOCUS GC Rear Panel

4. Unscrew the four Allen fixing screws, as shown in A of Figure 15-7 .

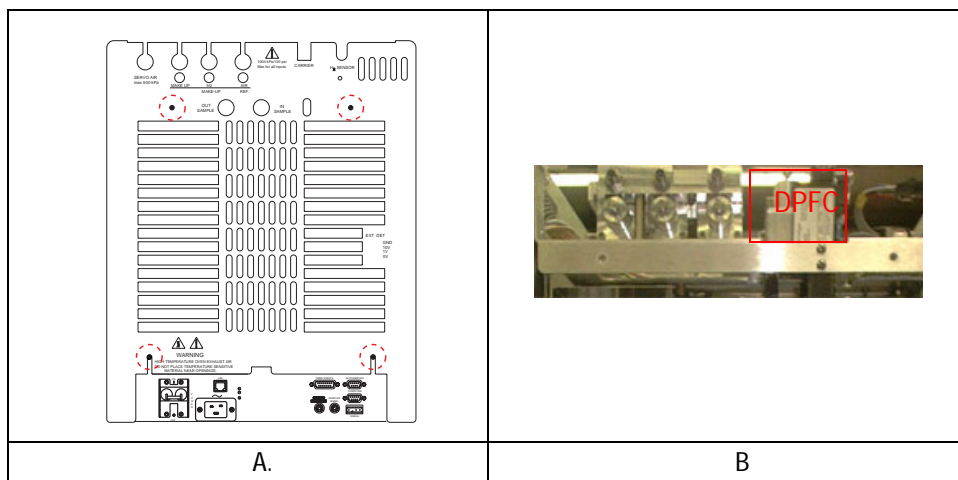

Figure 15-7. FOCUS GC Rear Panel

5. Lift the panel pulling it upward.



CAUTION To remove completely the rear cover, its GND cable must be also disconnected.

Replace the Carbon Filter

6. Identify the DPFC module. See B of Figure 15-7.
7. Referring to Figure 15-8, replace the filter operating as follows:

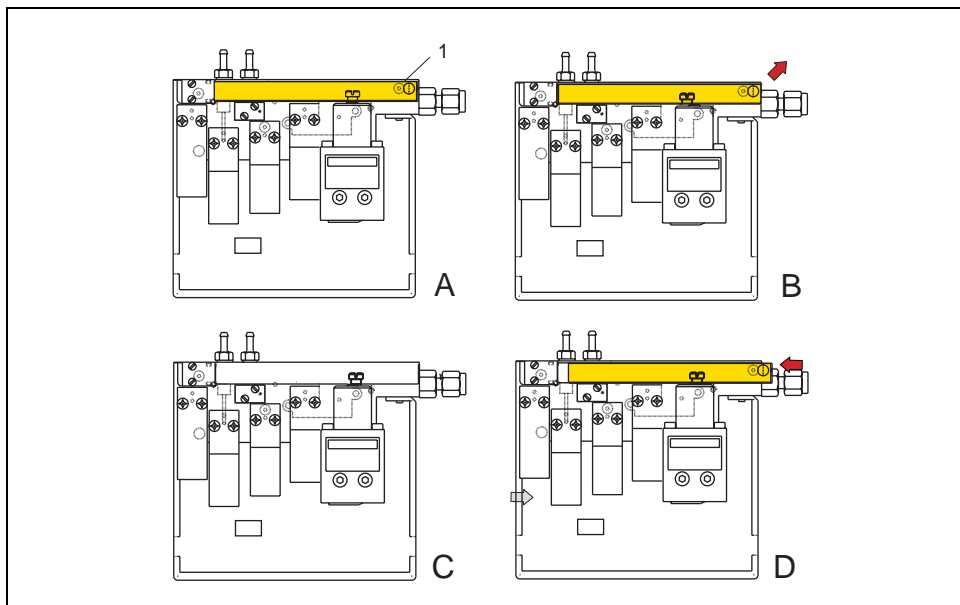

Figure 15-8. Filter Replacing

- a. Unscrew the fixing Allen screw 1.
- b. Slightly lift the filter.
- c. Pull the filter to extract it from its seat.
- d. Replace the filter with a new one proceeding in the reverse order of its removal.

Reinstall the GC Panels

8. Reinstall the GC real panel and the top cover proceeding in the reverse order of their removal.

Maintaining a PPKD Injector

The Purged Packed Column injector and its interface module will normally be serviced by Thermo Fisher Scientific authorized technical personnel.

In order to operate at peak performances, the injector requires periodic maintenance from the user. This maintenance includes:

- the replacement of the septum
- the cleaning or replacement of the liner.

When replacing the septum

The septum must be replaced at least every 200 injections, or every time a problem occurs related to a septum damage or wear.

It is good practice to replace the septum every time the liner is replaced.

When replacing the liner

The liner must be replaced periodically, depending on the number of injections performed and on the characteristics of the samples injected. The most common symptom indicating that the liner should be replaced is the appearance of tailing peaks in the chromatogram, particularly for polar compounds.

You can replace the liner with a new one or clean the liner and reinstall it.

Every time the liner is replaced, it is a good practice to replace the septum too.

The following Operating sequences help you to maintain properly the PPKD injector:

- *Replace the PPKD Septum*
- *Replace or Clean the PPKD Liner*

OPERATING SEQUENCE

Replace the PPKD Septum

Material needed

- Non metallic sharp tool
- Septum
- Tweezers



WARNING! This operation must be carried out at low temperature to avoid burns. Therefore, before beginning the sequence, the injector must be cooled to room temperature.

Preliminary Operations

1. While in Standby condition, in **OVEN** menu set the oven temperature to 30 °C.
2. In **INLET** menu set the inlet temperature to 0 (0 = Off).
3. When the inlet reaches the room temperature, enter in **CARRIER** menu, scroll to Pressure and set it to 0 (0 = Off).

OVEN		
Temp	30	30

INLET		
Temp	25	Off

CARRIER		
Pressure	0	Off

Removing the Septum

4. Unscrew the septum cap.
5. Remove the septum using a non metallic sharp. See A of Figure 15-9
6. Insert a new septum into the septum cap. See B of Figure 15-9.



CAUTION Use tweezers to avoid touching the septum with your fingers.

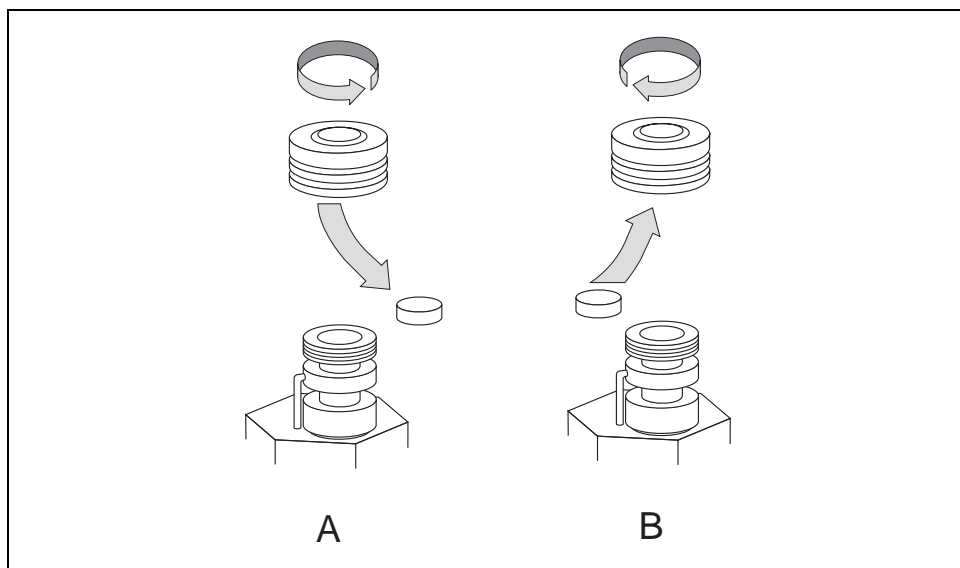

Figure 15-9. PPKD Injector Septum Replacement

7. Tighten the injector cap to finger tight.



CAUTION Do not overtighten the injector cap. You could damage the septum and affect performance.

Restart the GC Conditions

8. In **CARRIER**, **OVEN** and **INLET** menus set the normal working conditions.
9. Perform an automatic leak check.

OPERATING SEQUENCE

Replace or Clean the PPKD Liner

Material needed

- Glass liner
- Ultrasonic bath
- Methanol/acetone mixture (1:1)
- Tweezers



WARNING! This operation must be carried out at low temperature to avoid burns. Therefore, before beginning the sequence, the injector must be cooled to room temperature. When handling organic solvents you must take precautions to avoid health hazards.

Preliminary Operations

1. While in Standby condition, in **OVEN** menu set the oven temperature to 30 °C.
2. In **INLET** menu set the inlet temperature to 0 (0 = Off).
3. When the inlet reaches the room temperature, enter in **CARRIER** menu, scroll to Pressure and set it to 0 (0 = Off).

OVEN		
Temp	30	30

INLET		
Temp	25	Off

CARRIER		
Pressure	0	Off

Removing the Liner

4. Unscrew the nut that retains the analytical column, then remove the column with the inserted ferrule. See A of Figure 15-10
5. Unscrew the retaining nut at the bottom of the injector. Remove the adapter and the liner then remove the ferrule. See B of Figure 15-10.

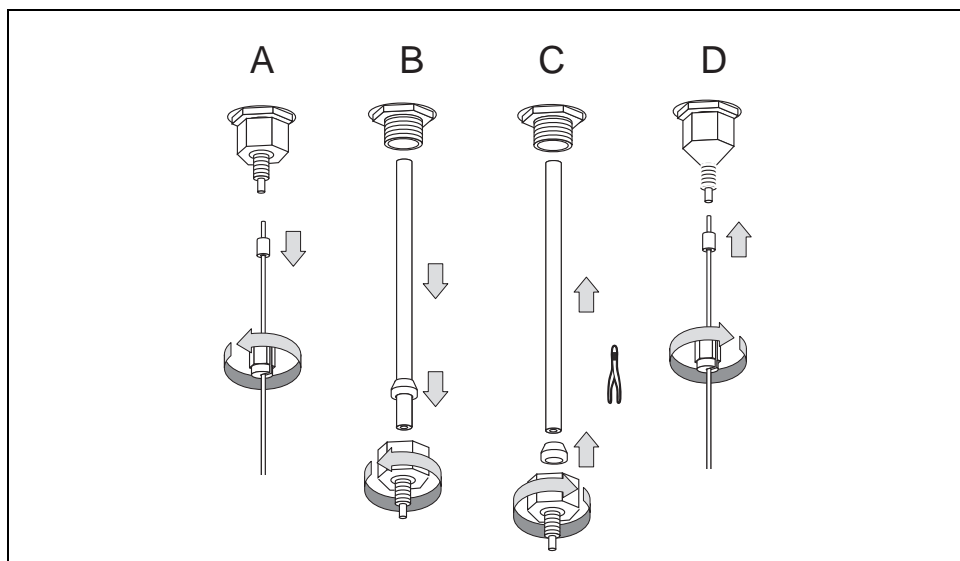

Figure 15-10. PPKD Injector Replace/Clean the Liner

6. If you are using a new liner, go to step 8. If you are cleaning the liner, put the dirty liner into an ultrasonic bath filled with a methanol/acetone mixture (1:1) and clean it for about half an hour.
7. Using tweezers, remove the liner from the bath and dry it with compressed clean air.

PRECAUTIONS



8. Insert a ferrule on the new (or cleaned) liner, using tweezers to hold it. See C of Figure 15-10.



CAUTION Be careful not to damage the graphite seal or allow graphite to enter the liner. Should this occur, clean the liner with an inert gas.

9. Insert the liner into the injector and push it gently upwards. Tighten the retaining nut with the adapter to close the bottom of the injector. See C of Figure 15-10.



NOTE

For trace analysis, you should pre-treat the liner with a suitable silylating reagent prior to inserting it into the injector.

10. Insert the analytical column with its ferrule into the bottom of the injector in its previous position, then tighten the M4 nut that retains the column. See D of Figure 15-10.

Restart the GC Conditions

11. In **CARRIER**, **OVEN** and **INLET** menus set the normal working conditions.
12. Perform an automatic leak check

Maintaining a FID

To ensure optimum performance of the FID, you must keep it clean and free of dust and deposits. Symptoms such as reduced sensitivity and increased noise indicate that detector needs cleaning. To properly maintain the FID, you should perform the following cleaning or replacement sequences:

- *Clean/Replace the FID Jet*
- *Clean/Replace the FID Collecting Electrode*
- *Replace the FID Ignition Assembly*

Figure 15-11 shows the Flame Ionization Detector components:

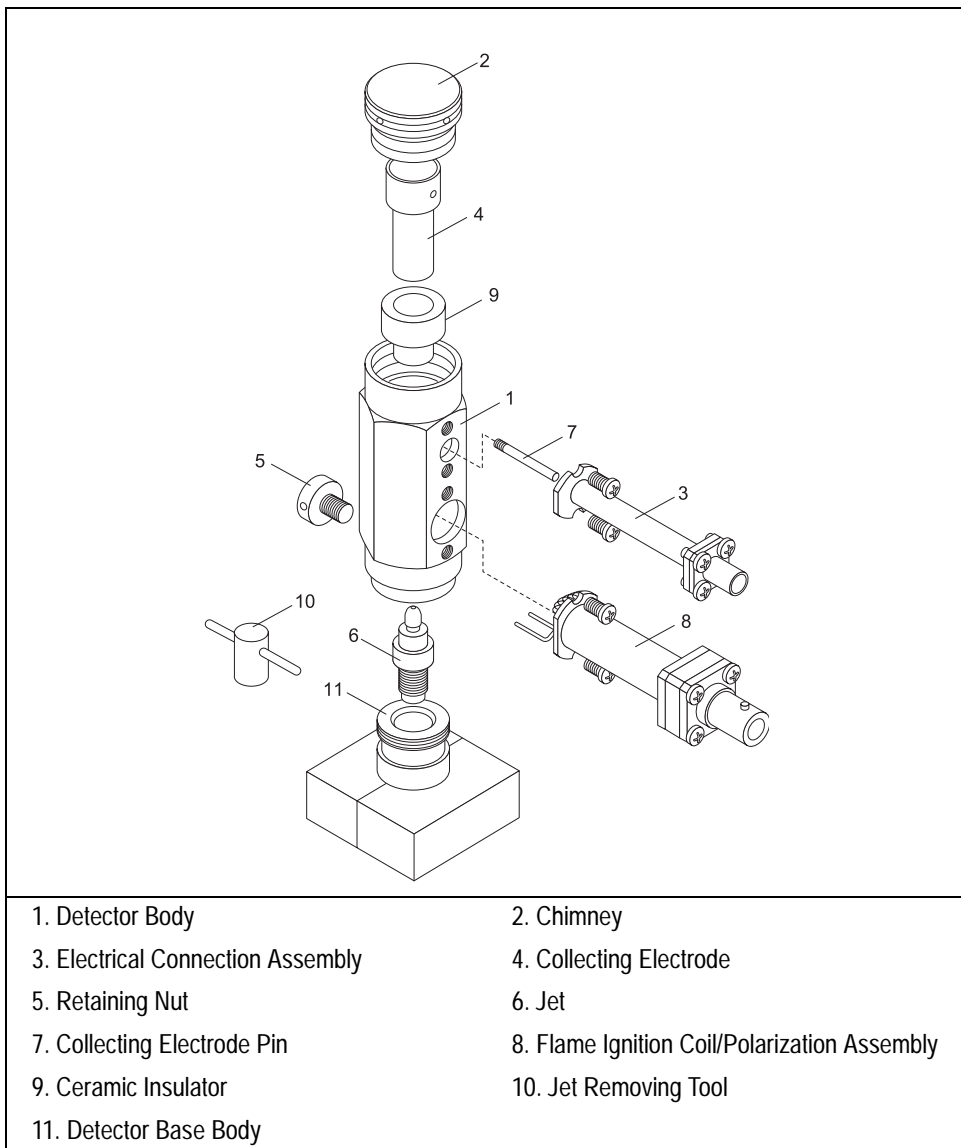

Figure 15-11. FID Parts Identification

OPERATING SEQUENCE

Clean/Replace the FID Jet

Material needed

- Screwdriver
- Tool for extracting the jet (P/N 205 019 00)
- Forceps or tweezers
- Ultrasonic cleaning bath
- Liquid detergent
- Clean compressed air
- GC-grade methanol
- Clean paper towel
- Jet for FID



WARNING! This operation must be carried out at low temperature to avoid burns. Therefore, before beginning the sequence, the detector must be cooled to room temperature. When handling organics solvents you must take precautions to avoid health hazards.

1. In **DETECTOR** menu, scroll to **Flame** and set **OFF**.
2. Scroll to **Temp** and set **OFF**.
3. Scroll to **H2** and **Air** and set **OFF**.

DETECTOR	
Flame	Off
Temp	25 Off
Signal pA	(0.0)
Ing. Thresh.	2.0
Flameout retry	Off
H2	Off
Air	Off
Make-up	Off

4. Disconnect the signal and ignition polarization cables from the detector.
See Figure 15-12.
5. Loosen the fixing screw on the front of the detector cell and remove it.
See Figure 15-12.

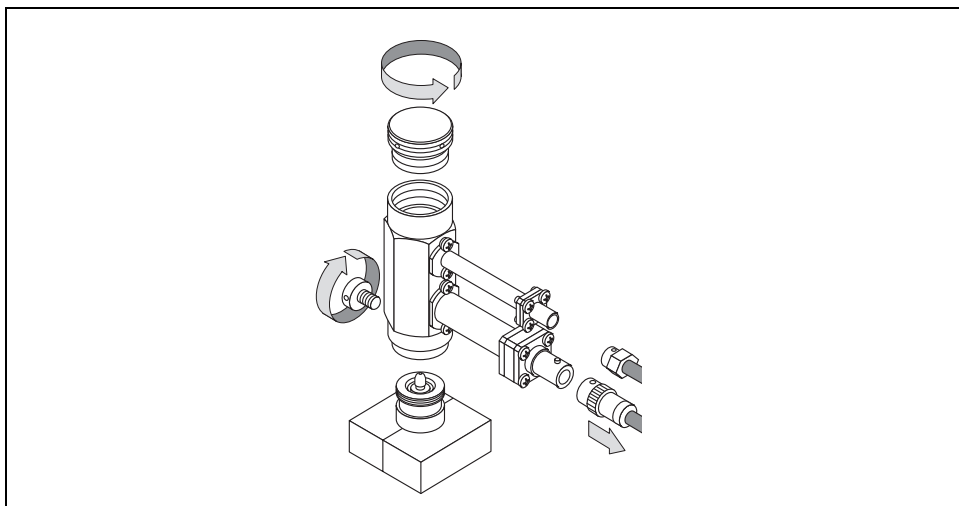

Figure 15-12. Clean/Replace the Jet (1)

6. Using the tool provided with the GC, unscrew the jet. See Figure 15-13.

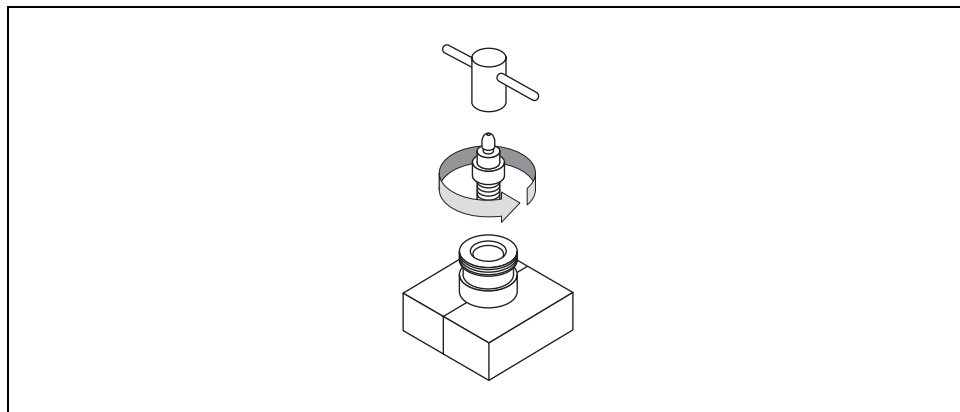

Figure 15-13. Clean/Replace the Jet (2)

- To clean the jet refer to *Clean the Jet* then continue from the point 7.
- To replace the jet refer to *Replace the Jet* then continue from the point 7.

Clean the Jet

- a. Place the jet in the ultrasonic bath filled with aqueous detergent and clean it for about five minutes.
- b. Handling the jet with forceps or tweezers, rinse the jet with distilled water, then with methanol.
- c. Place the jet on a paper towel and let it air dry. When the jet is dry, place the jet into the housing and tighten it with the proper tool. Ensure the jet is perfectly vertically aligned to avoid damaging its ceramic part.

Replace the Jet

- a. Place a new jet into the housing and tighten it with the proper tool. Ensure the jet is perfectly vertically aligned to avoid damaging its ceramic part. See Figure 15-14.

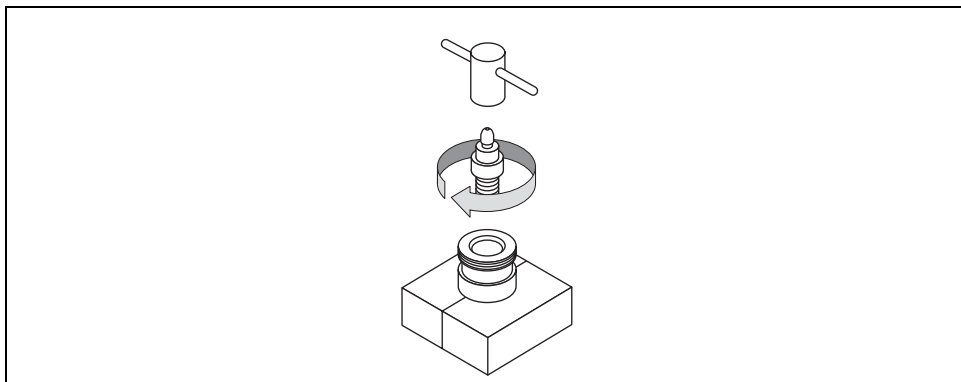

Figure 15-14. Clean/Replace the Jet (3)

7. Place the detector cell on the detector base body and tighten the fixing screw on front of the detector cell.
Reconnect the signal and ignition cables to the detector. See Figure 15-15

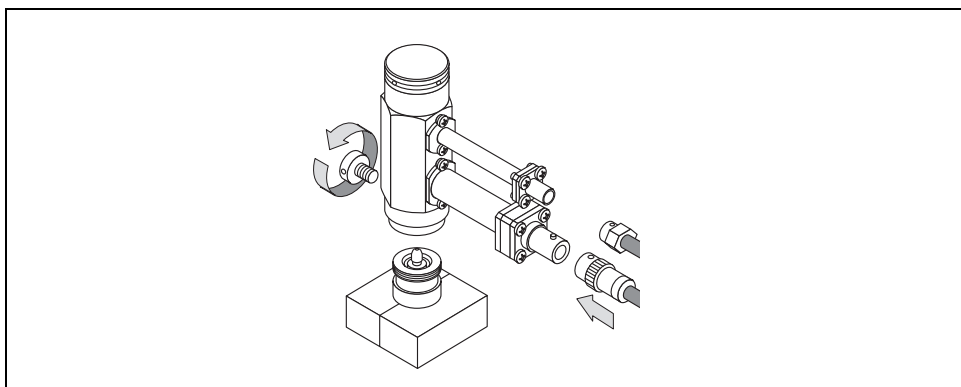

Figure 15-15. Clean/Replace the Jet (4)

8. Reset the detector to the required operating conditions.

OPERATING SEQUENCE

Clean/Replace the FID Collecting Electrode

Material needed

- Screwdriver
- Pliers
- Forceps or tweezers
- Ultrasonic cleaning bath
- Liquid detergent
- Clean compressed air
- GC-grade methanol
- Clean paper towel
- Collecting electrode



WARNING! This operation must be carried out at low temperature to avoid burns. Therefore, before beginning the sequence, the detector must be cooled to room temperature. When handling organics solvents you must take precautions to avoid health hazards.

1. In **DETECTOR** menu, scroll to **Flame** and set **OFF**.
2. Scroll to **Temp** and set **OFF**.
3. Scroll to **H2** and **Air** and set **OFF**.

DETECTOR	
Flame	Off
Temp	25 Off
Signal pA	(0.0)
Ing. Thresh.	2.0
Flameout retry	Off
H2	Off
Air	Off
Make-up	Off

4. Disconnect the signal and ignition polarization cables from the detector. See Figure 15-16.
5. Loosen the fixing screw on the front of the detector cell and remove it. See Figure 15-16.
6. Unscrew and remove the cap of the detector cell. See Figure 15-16.

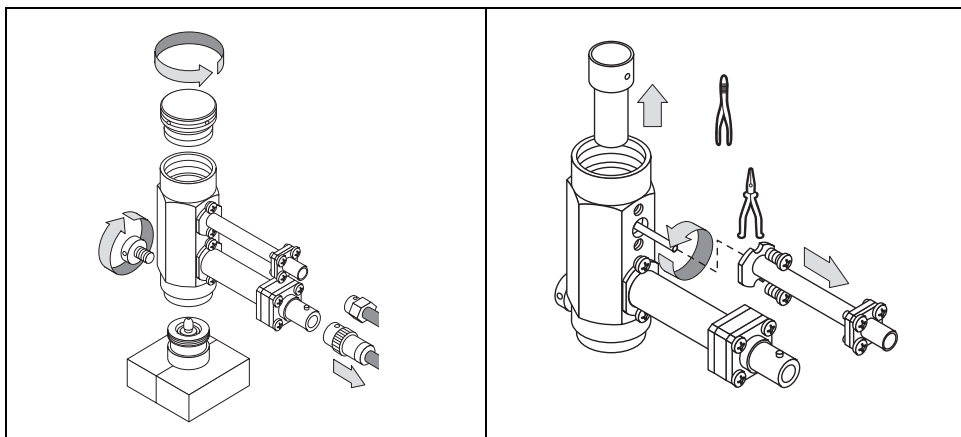

Figure 15-16. Clean/Replace the Collecting Electrode (1).

7. Remove the holder assembly of the signal cable by unscrewing the two screws that fix it on the detector cell.
8. Using forceps, unscrew and remove the gold contact pin.

9. Using tweezers, extract the collecting electrode through the top of the detector cell.
 - To clean the collecting electrode refer to *Clean the Collecting Electrode* then continue from the point 10.
 - To replace the collecting electrode refer to *Replace the Collecting Electrode* then continue from the point 10.

Clean the Collecting Electrode

- a. Place the collecting electrode in the ultrasonic bath filled with liquid detergent and clean it for about five minutes.
- b. Handle the collecting electrode with forceps or tweezers; rinse it using distilled water, then methanol.
- c. Place the collecting electrode on a paper towel and let it air dry.
- d. When the electrode is dry, place it in its housing. Ensure the insert hole is perfectly vertically aligned with the hole on the cell.

Replace the Collecting Electrode

- a. Place the new collecting electrode into its housing. Ensure the insert hole is perfectly vertically aligned with the hole on the cell. See Figure 15-17.

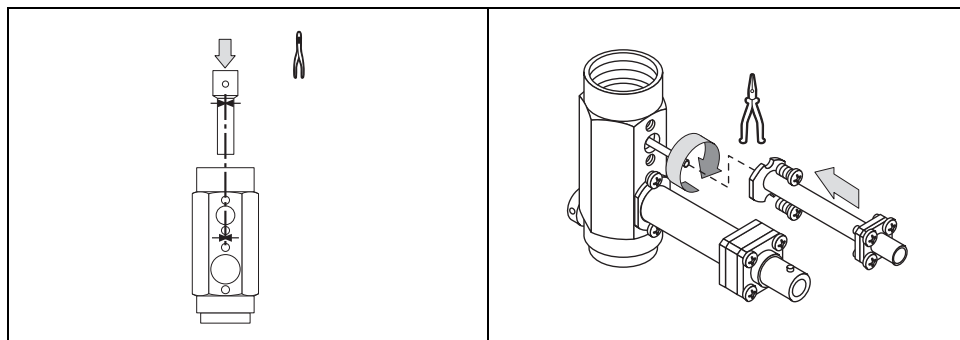

Figure 15-17. Clean/Replace the Collecting Electrode (2)

10. Using forceps, reconnect the gold contact pin. See Figure 15-17.
11. Remount the connector holder assembly, verifying the contact efficiency. See Figure 15-17.
12. Screw the detector cap into its housing. See Figure 15-17.
13. Place the detector cell on the base body and tighten the fixing screw. See Figure 15-18.

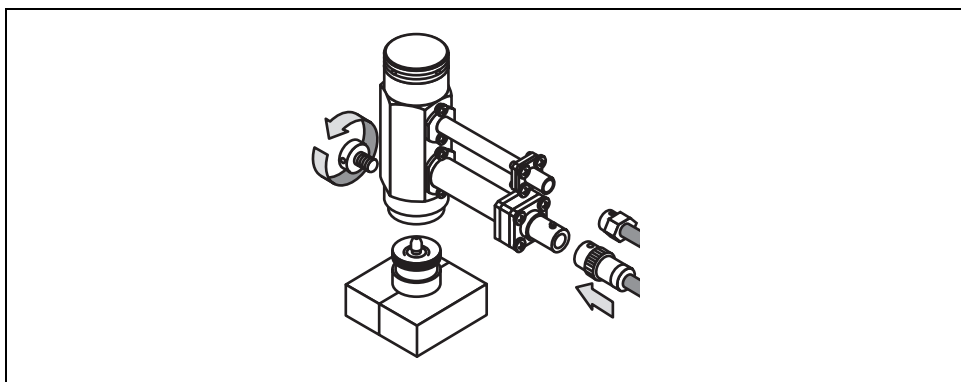

Figure 15-18. Clean/Replace the Collecting Electrode (3)

14. Reconnect the signal and ignition cables to the detector. See Figure 15-18.
15. Reset the detector to the required operating conditions.

OPERATING SEQUENCE

Replace the FID Ignition Assembly

Material needed

- Screwdriver
- Connector Holder Assembly



WARNING! This operation must be carried out at low temperature to avoid burns. Therefore, before beginning the sequence, the detector must be cooled to room temperature. When handling organics solvents you must take precautions to avoid health hazards.

1. In **DETECTOR** menu, scroll to **Flame** and set **OFF**.
2. Scroll to **Temp** and set **OFF**.
3. Scroll to **H2** and **Air** and set **OFF**.

DETECTOR		
Flame		Off
Temp	25	Off
Signal pA	(0.0)	
Ing. Thresh.	2.0	
Flameout retry		Off
H2		Off
Air		Off
Make-up		Off

4. Disconnect the signal and ignition polarization cables from the detector. See Figure 15-19.
5. Loosen the fixing screw on the front of the detector cell and remove it. See Figure 15-19.

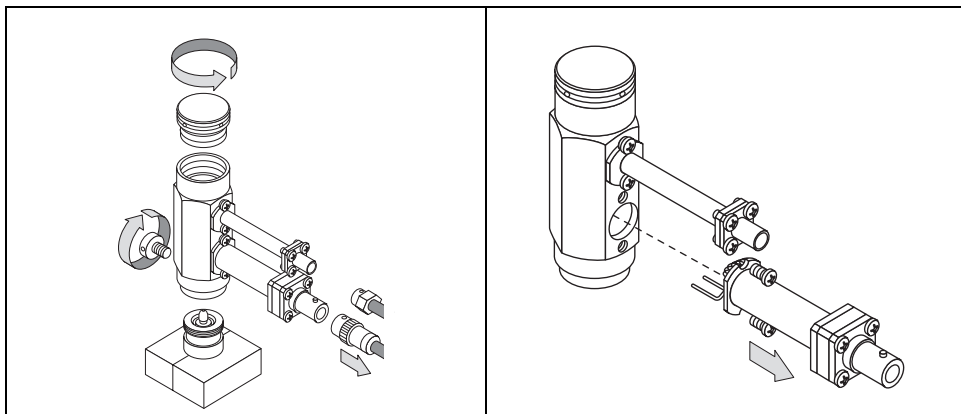

Figure 15-19. Replace the Ignition Assembly (1).

6. Unscrew the two fixing screws and remove the lower connector holder assembly from the detector cell. See Figure 15-19
7. Remount the new connector holder assembly and fix it to the detector cell using the two screws.
8. Make sure the connecting fork is placed downwards to achieve the correct contact with the jet. See Figure 15-20.

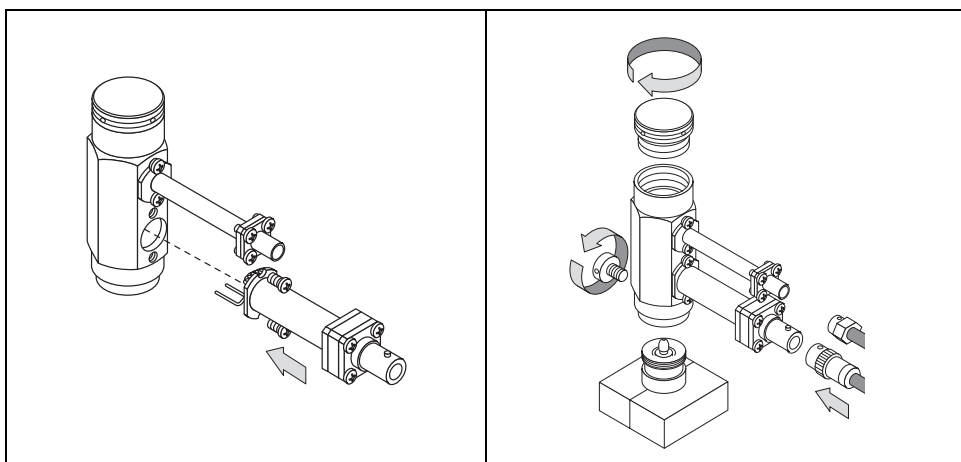

Figure 15-20. Replace the Ignition Assembly (2)

9. Place the detector cell on the detector base body and tighten the retaining screw. See Figure 15-20.
10. Reconnect the signal and ignition cables to the detector. See Figure 15-20
11. Reset the detector to the required operating conditions. See Figure 15-20.

FID Troubleshooting

Change in Sensitivity

The sensitivity of the Flame Ionization Detector depends on the carrier and detector gases flow rates and to the detector temperature.

Gases

The carrier gas flow range depends on the type of the gas used and on the type and diameter of the capillary column installed.

Table 15-2. Gases used for FID

Carrier gas	Detector Gas	Make-up gas Gas
Helium	Hydrogen + Air	Nitrogen (recommended)
Nitrogen		Helium
Hydrogen		

The detector gases (fuel and make-up gas) are controlled by a non-DGFC control module. The flow values are already adjusted in the factory before shipment as indicated in Table 15-3.

Table 15-3. Gas for FID Flow Rates

Gas	Flow rate
Hydrogen	35 mL/min
Air	350 mL/min
Make-up gas	30 mL/min

Because to gain optimum analytical performance from the FID the hydrogen flow rate has been experimentally optimized. To obtain the maximum signal intensity for the components of interest, the carrier and air flows must be maintained constant. An incorrect hydrogen flow rate reduces the FID sensitivity. The flow rate of the air is less critical than the hydrogen one. An excessive amount of air will destabilize the flame, causing noise and eventual flameout. A low flow rate of air would reduce the detector sensitivity.



NOTE

Generally the air flow rate must be set to about 10 times the hydrogen flow rate to keep the flame lit.

For high sensitivity applications, it is essential that you exclude all traces of organic contamination from the chromatographic system and/or from the gas lines of the detector. Such contamination would cause ghost peaks in the chromatogram or, more commonly, an unstable baseline.



WARNING! It is the customer's responsibility to ensure compliance with all local safety regulations concerning gas supplies.

Hydrogen is a potentially dangerous gas. Mixed with air it may give rise to an explosive mixture. The use of hydrogen requires the operator's extreme caution due to the risks involved. For further details concerning hydrogen, please refer to [Using Hydrogen](#) on page xxiii.

Flame Ignition

You can ignite the flame as soon as the detector temperature has reached 150 °C. After the flame appears to have ignited, check for water vapor condensed on a mirror or on the polished end of a wrench directly over the FID exit. You should observe steam condensing on the cold surface. If not, the flame is not ignited.



WARNING! Do not lean over the FID to see the flame, it is invisible.

Table 15-4 reports the possible causes of flame ignition problems and the relevant remedies.

Table 15-4. Difficulty in Igniting the Flame

Cause	Remedy
Incorrect fuel gas flows	Make sure that all flows are correct.
Defective igniter	Check the igniter element. Refer to the Replace the FID Ignition Assembly Operating Sequence on page 292 for instructions.

Table 15-4. Difficulty in Igniting the Flame (Continued)

Broken or cracked flame jet	Replace jet. Refer to the <i>Clean/Replace the FID Jet</i> Operating Sequence on page 284 for instructions.
Blocked jet tip	Check for a blocked jet by measuring the hydrogen flow with a flowmeter. Refer to the <i>Measuring the Detector Gas Flows with a Bubble Meter</i> Operating Sequence on page 78 for instructions. If required, remove and clean the jet following the <i>Clean/Replace the FID Jet</i> Operating Sequence on page 284.
Faulty electronics	Contact your customer support organization. Appendix B, <i>Customer Communication</i> , contains contact information for Thermo Fisher Scientific offices and affiliates worldwide.
Contamination	Contact your customer support organization. Appendix B, <i>Customer Communication</i> , contains contact information for Thermo Fisher Scientific offices and affiliates worldwide.

Maintaining a TCD

The TCD detector does not usually need current maintenance. Nevertheless, if you follow a few simple sequences, you will prolong the detector's lifetime. Pay a special attention to avoid contamination or damage of the filaments.

Follow these simple rules:

- Avoid to activate/deactivate the bridge when not necessary. This operation could considerably reduce the filaments lifetime.
- Avoid injecting samples that contain halogenated or acid compounds at high concentrations.
- Ensure that oxygen (air) could not enter into the filaments cells. Oxidation would irreversibly damage the filaments. Install traps for moisture and oxygen on the gas lines to reduce the hazard.



WARNING! Set `Filament power` to `Off` before disconnecting the column from the detector. When the column is disconnected, air will enter into the cell and the filament, if powered, will burn.

For the same reason set `Filament power` to `On` only if the column has been connected. It is a good practice to let the reference and make-up gases flow through the cells for 10-15 minutes before powering the filaments.

Figure 15-21 shows the Thermal Conductivity Detector components.

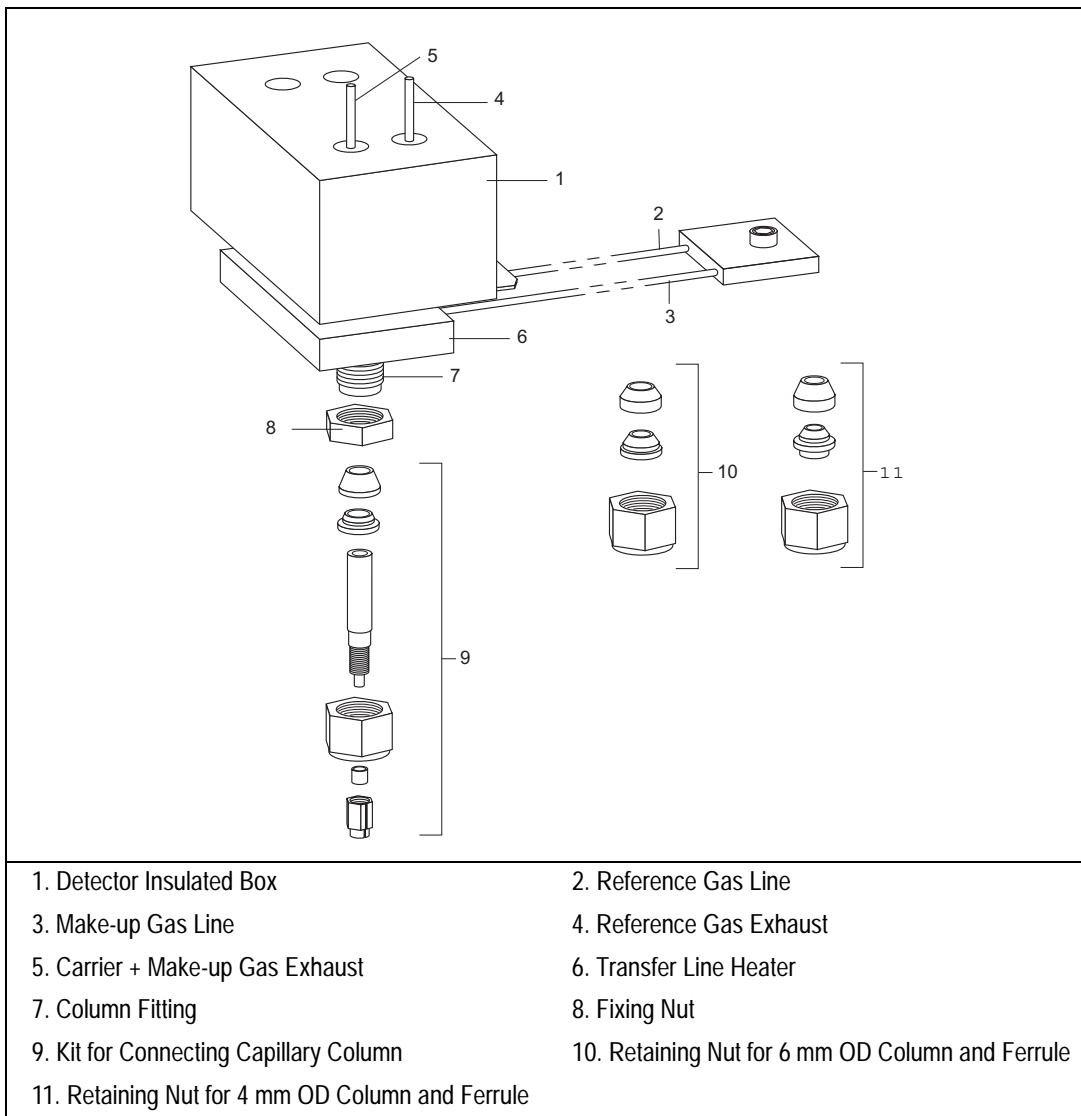

Figure 15-21. TCD Components

TCD Troubleshooting

Sensitivity

Sensitivity is related to the detector temperature (increasing temperature reduce sensitivity) and to the flow rate of the carrier, reference and make-up gas. A gain in sensitivity can be obtained increasing the gap between the temperature of the block and that of the filaments or increasing the filaments voltage.

Sensitivity is strictly related to the state of the filaments and to their operating conditions. A significant reduction of the detector sensitivity may be caused by the contamination of the filaments due to degradation of high molecular weight compounds inside the cell or to contaminated gases.

Low temperatures of the detector block may cause high boiling compounds condensate on the filaments reducing sensitivity.

Baseline drift

A small baseline drift normally occurs during a temperature program and does not indicate a trouble. This effect is due to the decrease of the carrier gas flow rate as temperature increases.

A baseline that suddenly goes out of scale and a rapid growth of the signal could indicate that filaments are likely to be burnt and have to be replaced.

Negative peaks

Negative peaks are normally generated by the sample components that have a thermal conductivity higher than carrier gas. For instance, using nitrogen or argon as carrier gas, negative peaks are obtained for helium, hydrogen or methane.

To revert the polarity of the detector, refer to *Detector Signal Parameters* in Chapter 9.

Troubleshooting the TCD

Table 15-5. TCD Troubleshooting Table

Symptom	Diagnosis	Remedy
Baseline fluctuations	Unstable regulation of the flow rate of the gases	Check the controllers of the carrier, reference and make-up gases work well.
	Leaks on the gas lines	Check the connections of the carrier, reference and make-up gas are tight.
	Inlet pressure of gases set too low	Set the pressure of the carrier, reference and make-up gas to a proper value.
	Trans temp set too high	Set Trans temp to a proper value (about 10 to 20°C below the Block temp value).
	Faulty temperature regulation	Contact your customer support organization. Refer to Appendix A, <i>Customer Communication</i> , for contact information.
Baseline drift	Unstable regulation of the flow rate of the gases	Check the controllers of the carrier, reference and make-up gases work well.
	Leaks on the gas lines	Check the connections of the carrier, reference and make-up gas are tight.
	Column conditioning not correctly performed	Recondition the column according to the manufacturer's instructions.
	Septum bleeding	Check the operating temperature of the septum is adequate. Replace the septum if necessary.

Table 15-5. TCD Troubleshooting Table (Continued)

Symptom	Diagnosis	Remedy
Low sensitivity	Leaks on the gas lines	Check the connections of the carrier, reference and make-up gas are tight.
	Leak due to septum wearing	Replace the septum.
	Operating conditions of the detector not properly set	Optimize working parameters of the detector according to the actual operating mode (Constant Voltage, Constant Temperature).
	Thermal conductivity of the carrier gas is too close to the one of the compound to be analyzed	Use a different carrier gas.
	Contaminated filaments	Remove contamination by baking the filaments for one hour at a temperature higher than the boiling point of the most high-boiling compound. Perform baking twice if necessary. If the symptom does not disappears, contact your customer support organization. Refer to Appendix A, <i>Customer Communication</i> , for contact information.

Table 15-5. TCD Troubleshooting Table (Continued)

Symptom	Diagnosis	Remedy
Baseline drift	Faulty temperature control	Contact your customer support organization. Refer to Appendix A, <i>Customer Communication</i> , for contact information.
Low sensitivity	Oxidized filaments	Contact your customer support organization. Refer to Appendix A, <i>Customer Communication</i> , for contact information.
The detector does not work. Message: Filament power Off	Lack of carrier, make-up or reference gas or pressure too low	Check the feed of the carrier, make-up and reference gas.
	Filament burnt	Contact your customer support organization. Refer to Appendix A, <i>Customer Communication</i> , for contact information.

Maintaining Gas Sampling Valve

The Gas Sampling Valve is normally be serviced by authorized technical personnel.

User could be required to install/replace the sampling loop. To perform this operation, please refer to the following operating sequence.

OPERATING SEQUENCE

How to Install/Replace the Loop of an Automatic Valve



WARNING! Before starting the FOCUS GC MUST BE SWITCHED OFF.

Operate as follows:

Remove the FOCUS GC Top Cover

The top cover is fixed on the main unit with two front screws and two clips.

1. Open the GC oven door.
2. Unscrew the two front screws, as shown in Figure 15-22, which remain on the main unit.
3. Remove manually the top cover pulling it up from the front, the two clips will be automatically unlocked.

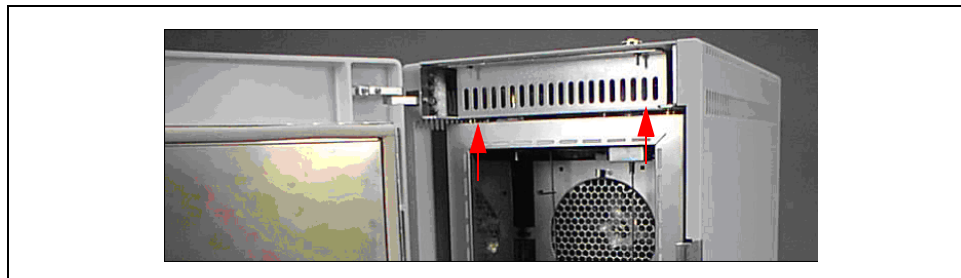

Figure 15-22. Top Aluminium Cover Removal

Remove the sampling loop

The sampling loop is connected between the valve ports **1** and **4** as shown in the scheme of Figure 15-23.

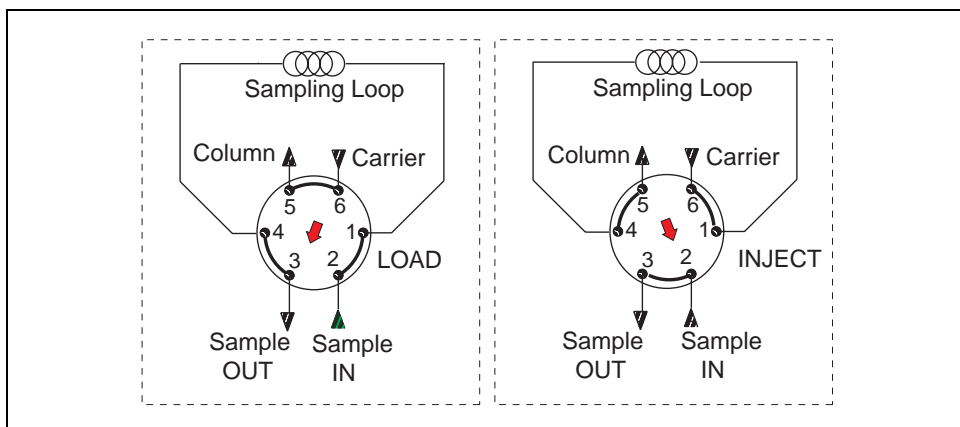

Figure 15-23. GSV Sampling Loop

- By using the 1/4-inch wrench, loosen the two fittings of the sampling loop, and remove it. See **A** and **B** of Figure 15-24.

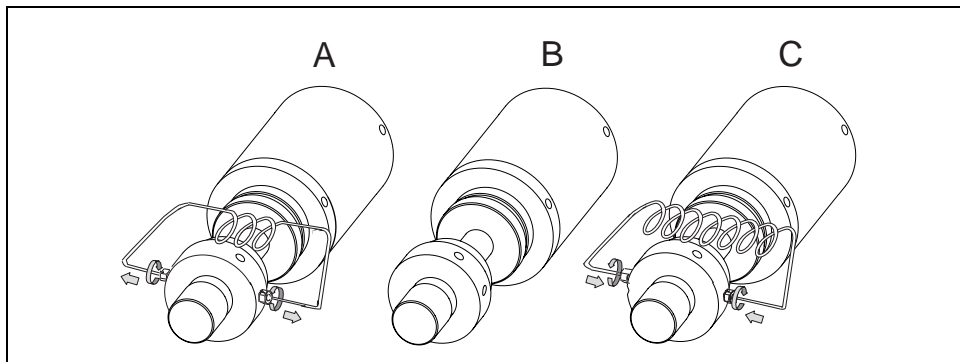

Figure 15-24. Sampling Loop Installation/Replacing

- Insert the new sampling loop then screw the two fittings by using the 1/4-inch wrench avoiding to overtighten them. See **B** and **C** of Figure 15-3.

Analytical Troubleshooting

This paragraph contains instructions for the instrument troubleshooting and a brief guide for the analytical troubleshooting.

Systematic approach is required to cause identification and problem solving. For this is purpose, a method as the following one is suggested.

Electrical Connections

- Ensure that the electrical line is grounded and the voltage supply stable.
- Verify that all the electrical connections between GC and eventual subsidiary units are correct.

Gases

- Verify that the carrier gas line is turned on.
- Verify that the detector gases are set to the correct flow rate.
- Check that leaks are not present in the system.

Injection

- Use syringe for gas chromatography having appropriate volume.
- The sample must be prepared and diluted correctly.
- Always inject the same sample volume.
- The split ratio must remain constant.
- If present, verify the autosampler performance.
- When an autosampler is used, the sample vials must be correctly crimped.

Chromatographic column

- The column must be compatible with the analysis to be carried out; correctly installed and conditioned before use.
- Verify that the column-to-inlet ferrule is not leaking.
- Verify the presence of gas leaking.

- Check the column efficiency periodically.

Detector

- Ensure that the detector parameters are correctly set.
- Check for eventual detector contamination.

Data System

- Check that the Data System in use is properly connected.

Instrument Troubleshooting

The control unit of the GC performs a number of test routines to monitor and report on the status of the major chromatographic and control functions. Instrument malfunctioning, due to a component failure or to abnormal operating condition is identified by the red lighting of the Not Ready/Error LED located on the GC Status Panel.

When lit, this LED indicates that the injector and oven power has been cut off for safety reasons and an error message indicating the possible cause of error appears on the display. See [Error Messages](#).

Error Messages

The following table reports the error messages and the explanation of the relevant correlated problem

Table 15-6. Error Messages

Message	Description
TEMP SHUTDOWN Loss of carrier	This message appears in two cases: The carrier supply may be missing and the actual pressure value is 0, or the actual pressure cannot reach the setpoint value.
HARDWARE SHUTDOWN Oven T over limits	The oven temperature exceeds the temperature limits (350 °C). Error may be due to a probe malfunctioning.

Table 15-6. Error Messages (Continued)

Message	Description
HARDWARE SHUTDOWN Inlet T over limits	The inlet temperature exceeds the temperature limits (375 °C). Error may be due to a probe malfunctioning.
HARDWARE SHUTDOWN Det T over limits	The detector temperature exceeds the temperature limits (375 °C). Error may be due to a probe malfunctioning.
HARDWARE SHUTDOWN X line T over limits	This message appears when a MS detector is connected to the GC instead of FID. The MS detector transfer line detector temperature exceeds the temperature limits. Refer to the relevant MS detector manual.
TEMP SHUTDOWN Oven not heating	The oven is not heating. Contact local TE Customer Support.
TEMP SHUTDOWN Inlet not heating	The inlet not heating. Contact local TE Customer Support.
TEMP SHUTDOWN Det not heating	The detector is not heating. Contact local TE Customer Support.
TEMP SHUTDOWN X-line not heating	The MS detector transfer line not heating.
TEMP SHUTDOWN Hydrogen alarm	Hydrogen flows inside the column oven. Probably leaks in the column connections or column breakage.
HARDWARE SHUTDOWN Undervoltage alarm	Voltage supply to electric circuits is too low.

Table 15-6. Error Messages (Continued)

Message	Description
TCD fil switched OFF Required flow not On	<p>The TCD filaments are set to Off for their protection.</p> <p>This message appears:</p> <ul style="list-style-type: none"> - When trying to switch the TCD filaments to ON with Reference gas Off. - When trying to switch the TCD filaments to ON with Carrier gas Off. - When the Carrier gas is switched to Off with the filaments On. - When the Reference gas is switched to Off with the filaments On. - HW signal of pressure switch from the TCD control board. <p>With any key the message page is exit, but the filaments must remain Off.</p>
AZ TCD out of range	<p>The TCD autozero failed when zeroing the TCD, the signal to subtract is higher than the maximum offset.</p> <p>Offset is set to Off.</p>
Autozero required!	<p>TCD offset is available only after the first AZ successfully carried out. Offset value is not changed.</p> <p>Refer to <i>Detector Signal Parameters</i> in Chapter 9.</p>

Guide to Solve Analytical Problems

Rectifying faults in a chromatographic system is relatively simple, provided a logical and systematic problem-finding procedure is adopted.

Most faults can be identified from the chromatogram especially for test mixtures and we strongly recommend that a test mix be injected periodically to test the efficiency of the chromatographic system as well as the detector performance.

Additionally, a leak must be performed should any part of the system be disturbed.

Finally, routine cleaning of injector and detector units will help to avoid problems occurring in the chromatographic system.

Baseline

Behavior	Characteristics	Cause	Remedy
Drifting		Accumulation of stationary phase	Replace the end section of the column.
		Carrier gas cylinder pressure too low to allow control	Replace the carrier gas cylinder or increase the pressure.
		Drifting carrier gas or combustion gas flows	Check the gas controllers.
		Accumulation of impurities in column	Check impurity levels in the gas source. Use correct gas purity.
	Falling	Carrier gas leak in the system	Perform a leak test and ensure the tightness of the connections on the carrier gas line.
		Column is baking out	Allow enough time for the column to stabilize.
	Rising	Accumulation of impurities in column	Check impurity levels in the gas source. Use correct gas purity.
		Contaminated detector	Check the detector and clean it.
	Rising under temperature program operation	Column contaminated	Recondition the column.
	High-standing current		Carrier gas flow rate too high
Contaminated column			Recondition the column.
Contaminated gases			Replace gas cylinders or gas filters.

Behavior	Characteristics	Cause	Remedy
High-standing current (continued)		Excessive column stationary phase bleeding	Check the oven temperature, ensuring it doesn't exceed the column upper limit. Recondition the column. Replace the column.
		Loose connections	Ensure all interconnections and screw connections are tight.
Irregular shape	Dip after solvent peak	Detector contaminated	Bake out or clean the detector.
	S-shaped	Excessive column bleed during column temperature programming	Reduce the upper column temperature. Bake out the column. Install a high temperature column.
		Oxygen contamination is decomposing the stationary phase	Install oxygen filters in carrier gas line. Check pneumatic and inlet systems for leaks. Use correct gas purity with low oxygen content.
Square waves	Large AC power fluctuations; heavy equipment on same line	Use a dedicated clean AC line of sufficient amperage	
Noise	High-frequency noise	Contaminated detector	Isolate the detector from electronics. If noise disappears, clean the collector.
		Combustion-gas flow too low or too high	Check the detector-gas flows
		Contaminated column	Condition the column.
		Contaminated detector gas supply	Check the gas purity and install appropriate filters
		Defective electrometer	Replace electrometer.

Behavior	Characteristics	Cause	Remedy
Noise (Continued)	High-frequency noise	Detector temperature higher than column maximum temperature	Reduce the detector temperature to the column temperature upper limit.
		External electrical interference	Attach an AC line monitor and check purity of the AC supply
		Loose column fittings	Tighten fittings accordingly.
		Loose detector electrical connections	Make sure the leads are properly connected.
Spiking		Defective electrometer or amplifier	Replace the electrometer or amplifier
		F.s. column too close to flame (FID)	Lower the column to the correct position (2-3 mm below the tip of the jet).
		Dirty jet or detector	Isolate the detector from the electronics. If noise disappears, clean the jet and collector.
		External electrical interference	Attach an AC line monitor and check the purity of the AC supply
		FID temperature too low	Increase the temperature to at least 150 °C

Peaks

Behavior	Characteristics	Cause	Remedy
Broadening		Column flow too high	Reduce the flow to slightly above optimum.
		Column flow too low	Increase the flow to slightly above optimum.
		Split flow too low in split injection	Increase the flow to 40-50 ml/min.
		Column performances degraded	Test the column at the optimum flow rate.
		Dirty injector	Clean or replace the liner.
		Stationary phase accumulated in the outlet	Remove the last two coils from the column.
		Detector base body temperature too low.	Increase the temperature to 5°C below the column maximum.
Clipping	at bottom	Detector or integrator zero set too low	Set the zero correctly.
	at top	Data system zoomed in too close	Zoom out to view the entire chromatogram.
		Detector or integrator attenuation set too low	Set the attenuation higher.
		Detector range too sensitive	Set a less-sensitive detector range.
		Incorrect input to recording unit	Correct and check the recording unit.
Double peaks		Injection speed too low	Inject more rapidly in a smooth motion.
		Wrong autosampler injection speed or mode	Use a higher speed.

Behavior	Characteristics	Cause	Remedy
Fronting		Column or detector overloaded	Decrease the injected amount and/or analyte concentrations. Increase the split ratio.
		Column temperature too low	Increase the temperature.
		Stationary phase too thin	Use a thicker-film column.
Ghost peaks		Contaminated carrier gas	Replace the cylinder or replace the filter.
		Contamination from laboratory glassware	Ensure the glassware is clean and contamination-free.
		Decomposition of injected sample	Decrease the injection port temperature.
		Dirty injection solution	Carry out adequate clean-up of sample prior to injection.
Ghost peaks	Broad ghost peaks	Contaminated inlet or pneumatics	Remove the column and bake out the inlet. Use a high-quality septum. Replace the split vent filter. Install an in-line filter between the pneumatics and the inlet.
		Incomplete elution of previous sample	Increase the final oven program temperature or total run time. Increase the column flow rate.
Irregular shape	Chair-shaped	Solvent flooding of column	Increase the initial oven temperature.
Negative peaks	All	Recorder unit signal wires connection is reversed	Verify the signal wires connection. Perform the proper connection

Behavior	Characteristics	Cause	Remedy
Negative peaks	Some	Symptom can be normal	
No peaks	after solvent peak	Carrier gas flow too high	Reduce the carrier gas flow rate.
		Combustion gas flow incorrect	Check the combustion gas flow.
		Detector contaminated	Bake out or clean the detector.
		FID flame extinguished by solvent peak	Check the detector temperature.
		Too much sample injected	Inject less sample.
		Incorrect column position in S/SL injector (too high)	Check the column position.
	at all	Clogged syringe needle	Replace or repair the syringe.
		Column broken or disconnected	Check the column and connections.
		Defective electrometer or amplifier	Replace the electrometer or amplifier.
		Defective recording device	Replace the recording device.
		FID flame is out	Light the flame.
		Poor or missing electrical connection	Check the cable connections.
		Incorrect column position in S/SL injector (too high)	Check the column position.
Tailing	Sample peaks	Column degradation causing activity	Inject a test mixture and evaluate the column.
		Column/oven temperature too low	Increase the column/oven temperature. Do not exceed the recommended maximum temperature for the stationary phase.
		Dirty liner	Clean or replace the liner.

Behavior	Characteristics	Cause	Remedy
<p>Tailing (continued)</p>	<p>Sample peaks (continued)</p>	Glass wool or inlet liner causing activity	Replace with fresh silanized wool and a clean inlet liner.
		Inlet temperature too low	Increase the inlet temperature
		Poor or obstructed column connections	Remake the column inlet connection.
		Wrong stationary phase	Replace the column according to the column manufacturer literature.
		Incorrect column position in inlet	Reinstall the column.
		Initial oven temperature too high (On Column)	Reduce the initial oven temperature.
		Septum purge flow too low and/or split/splitless vent flow too low	Check and adjust the septum purge and vent flows.
		Too large injection size	Reduce the injection size.
<p>Unresolved peaks</p>	Carrier gas flow rate too high	Reduce the carrier gas flow rate	
	Column deteriorated	Replace the column	
	Column temperature too high	Lower the column oven temperature	
	Column too short	Use a longer column	
	Incorrect column choice	Install a suitable column	
	Injection technique is not adequate	Choose a correct injection technique	

Results

Behavior	Characteristics	Cause	Remedy
Low reproducibility of peaks area		Concentration not compatible with the dynamic range of the detection system	Ensure that the sample concentration is suitable for the detection system.
		Inappropriate injection technique	Try a different injection technique.
		Injection parameters inappropriate	Check the injection temperature and flow rates.
		Non reproducible sample injection technique	Evaluate the sample preparation sequences. Compare the results with a series of standard injections.
		Leaking syringe or septum	Check and replace the syringe and/or septum at regular intervals.
		Leaks at the injection	Check the column connections. Run a leak check.
		Poor injection technique	Carefully meter the injected amount. Use a clean, good-quality syringe.
		Poor split flow or ratio control	Monitor the flow. Replace the in-line filter.
Poor sensitivity	with increased retention time	Carrier gas flow rate too low	Increase the carrier gas flow rate. Locate and remove possible obstructions in the carrier gas line. Check the injector/column ferrules.

Behavior	Characteristics	Cause	Remedy
Poor sensitivity (Continued)	with normal retention time	Leaks in the GC carrier gas line.	Run a leak test and correct leaks.
		Syringe leaks during injection	Replace syringe or piston seals, if applicable.
		Split injection temperature too low	Increase the temperature of the injector.
Retention times	Decreasing	Stationary phase deteriorated by oxygen and/or water	Use a carrier gas free of oxygen and water.
		Stationary phase loss due to column bleeding	Reduce the column temperature.
	Increasing	Increasing carrier leakage	Check the septum and column connections.
		Carrier gas supply running out	Replace the bottle.
	Low reproducibility	Drifting or unstable pneumatic controller	Monitor the column pressure or flow. Check and replace the controller if necessary.
		Poor injection technique	Start the run at consistent time after injection.
		Sample size is too large	Reduce the injected amount and/or volume.
		Unstable column temperature	Check the main oven door and cooling flap. Monitor the column temperature.

LAN Option Set-up

This chapter contains notes on how to set-up and start using the FOCUS GC with the LAN (Local Area Network) option.

Chapter at a Glance...

Introduction	322
Set-Up	324

Operating Sequences

How to Set up the FOCUS GC LAN	324
--	-----

Introduction

The FOCUS GC LAN version is basically an instrument equipped with a CPU featuring LAN (Local Area Network) capabilities. The FOCUS GC LAN is easily recognizable by the presence on the rear panel of a RJ45 connector, 2 LEDs for LAN activity and a reset button.

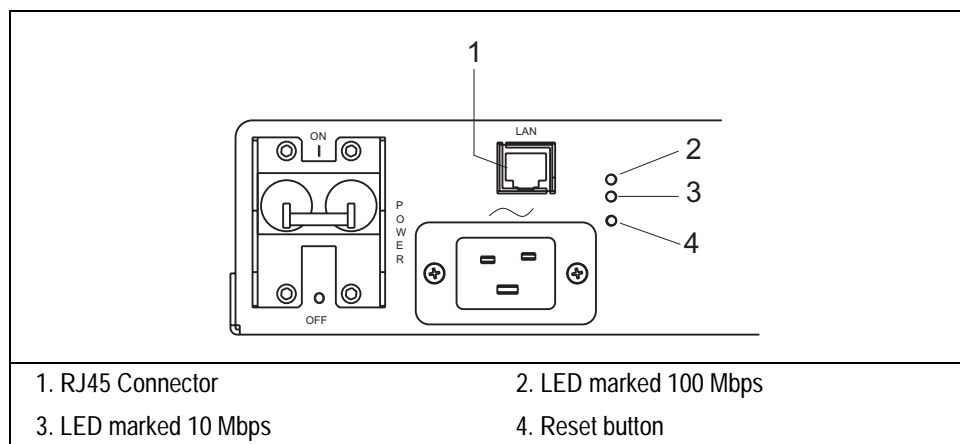

Figure 1-1. FOCUS GC Rear Panel

IP Address and LAN Communication Port

The FOCUS GC LAN is shipped with a default IP address.

To change the default values, contact your LAN administrator and ask for the IP address to be assigned, the netmask, and eventually the port.

- The IP address is a 3 digits x 4 fields number given by the network administrator e.g. 192.168.127.10
- The netmask is a 3 digits x 4 fields number given by the network administrator e.g. 255.255.255.0
- The port is a 4 digits number given by the network administrator e.g. 4001 (4001 is usually the CPU/LAN default)

The default IP address of the FOCUS GC LAN CPU is **192.168.127.254**.

Reset Button

To reset the IP address and communication port to default values, push the reset button, located on the rear panel of the FOCUS GC, for at least 5 seconds.

Network Cables

Two network cables are included in the standard outfit of the FOCUS GC LAN:

- a reversed RED patch for computer to FOCUS GC direct connection. This is used for the initial set-up operation.
- a standard GREY patch for FOCUS GC to local area network connection. This is used for normal use.

Set-Up

To set the desired IP and set up the LAN communication port of the FOCUS GC then to configure the data system, please follow the instruction reported in *How to Set up the FOCUS GC LAN* operating sequence.

OPERATING SEQUENCE

How to Set up the FOCUS GC LAN

Material required

- PC (desktop or portable)
- Network connecting RED cable
- Network connecting GREY cable

Proceed as follows:

Verify that the GC and the PC are switched off.

1. By using the LAN reversed RED patch included in the standard outfit, connect a PC (desktop or portable) directly to the RJ45 connector marked LAN located on the rear panel of the FOCUS GC power module.
2. Switch on the GC as well as the PC.
3. Make sure your PC communicates with the CPU/LAN IP. To do this, from the Start menu, run the “Command Prompt” and type “**Ping 192.168.127.254**”. The FOCUS GC LAN should answer as reported in the following figure.

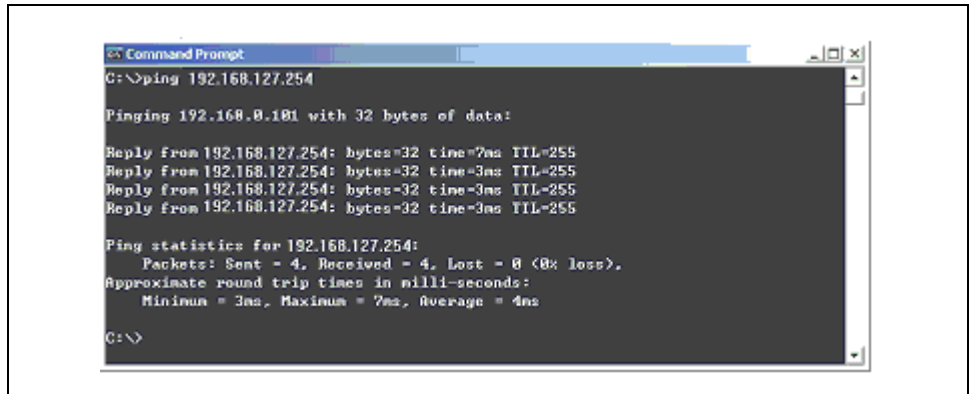

```
Command Prompt
C:\>ping 192.168.127.254

Pinging 192.168.0.101 with 32 bytes of data:

Reply from 192.168.127.254: bytes=32 time=7ms TTL=255
Reply from 192.168.127.254: bytes=32 time=3ms TTL=255
Reply from 192.168.127.254: bytes=32 time=3ms TTL=255
Reply from 192.168.127.254: bytes=32 time=3ms TTL=255

Ping statistics for 192.168.127.254:
    Packets: Sent = 4, Received = 4, Lost = 0 (0% loss),
    Approximate round trip times in milli-seconds:
        Minimum = 3ms, Maximum = 7ms, Average = 4ms

C:\>
```

- If the default IP address 192.168.127.254 is reachable, please go to paragraph [How to operate when the IP address is reachable](#).
- If your PC is not able to communicate with the default IP address, it is necessary to set your computer to a different IP address, following the instruction reported in paragraph [How to operate when the IP address is not reachable](#).

How to operate when the IP address is not reachable

1. Select the Local Area Network connection properties of your computer (please refer to specific operating system instructions to access this configuration).

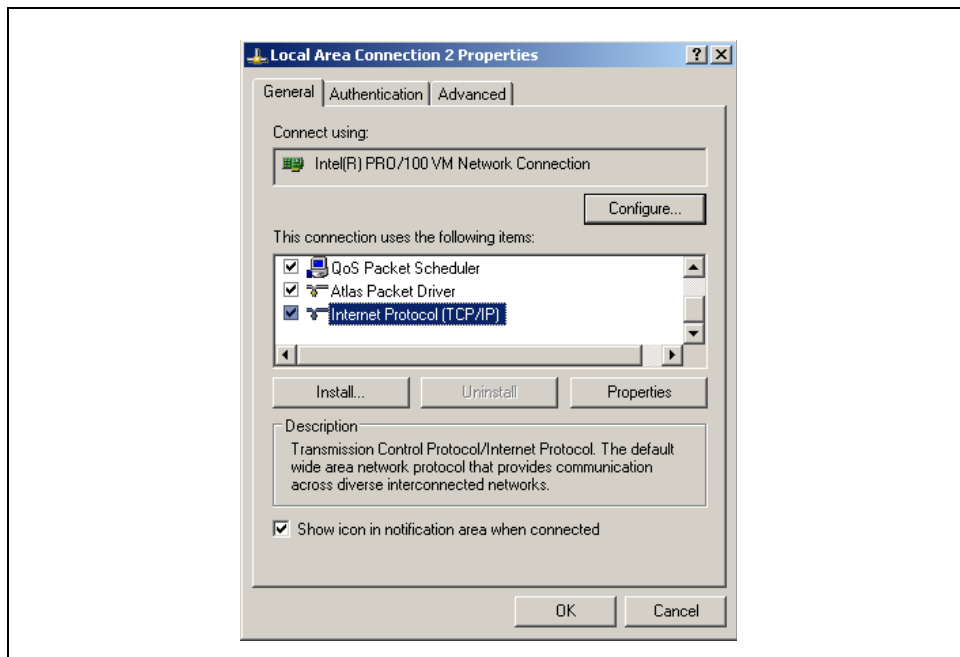

2. Select the “Internet Protocol TCP/IP” and then click on **Properties**.
3. Make sure the IP address of the computer you are using is set for same subnet of the default IP address of the FOCUS GC LAN.
It may be any IP in the range 192.168.127.1 to 192.168.127. 253. Please also set the subnet as reported in the next figure.

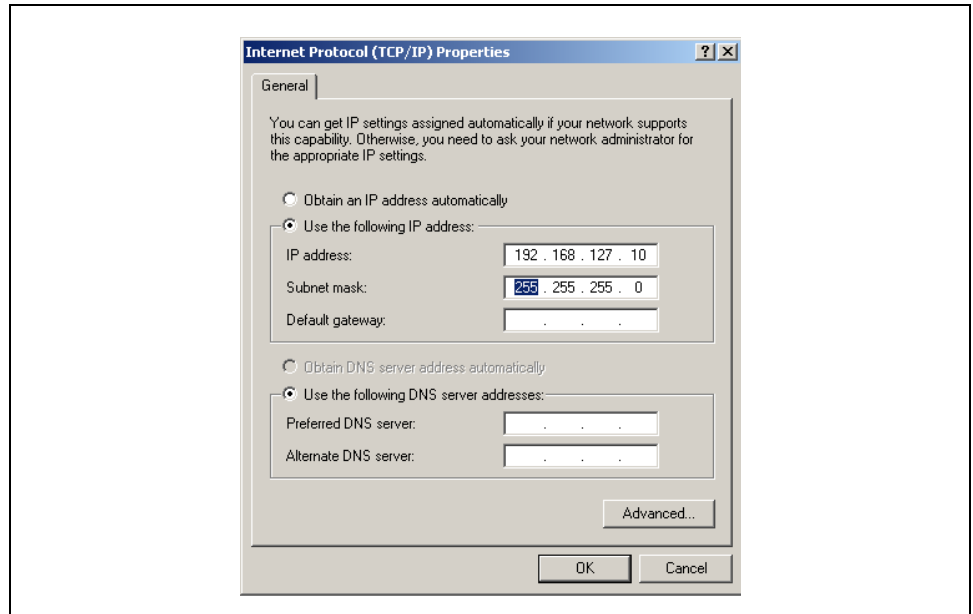

- At this point confirm by clicking **OK**, and restart from point **3** to make sure the FOCUS GC LAN default IP is now reachable.

**NOTE**

Should you still have problems, please check the cable connection, and go through the reset procedure of the FOCUS GC CPU. The CPU/LAN is hence reset to the default IP address. It may happen that for some reason the IP address has been previously changed from default to another IP address and therefore a reset procedure is advisable. Refer to [Reset Button](#) on pagina 323.

- Proceed following the instructions reported in paragraph [How to operate when the IP address is reachable](#)

How to operate when the IP address is reachable

When the IP is reachable it means that the PC is communicating with the FOCUS GC LAN. It is now possible to set the LAN communication port.

- Start a command prompt and type **telnet 192.168.127.254**

2. The telnet program connects to the IP 192.168.127.254 and shows the following page:

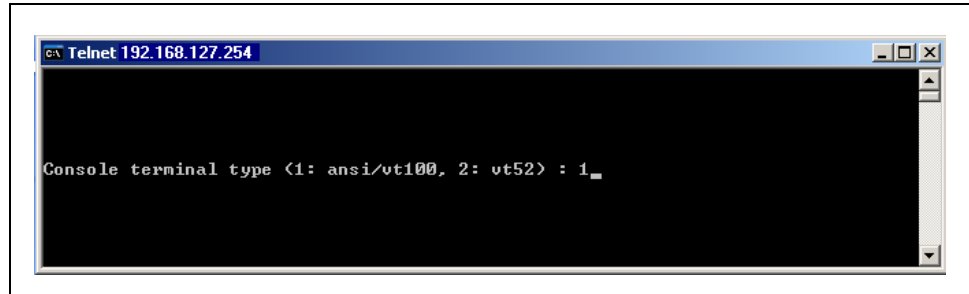

3. Confirm the default selection (1) by pressing **ENTER**. The following page will be visualized.

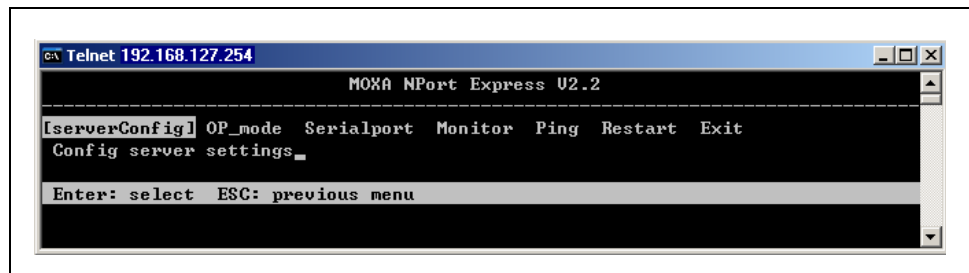

With **ARROWS**, **ENTER** and **ESC** keys you'll navigate the program.

4. Select **server Config** to enter the new IP address and netmask.

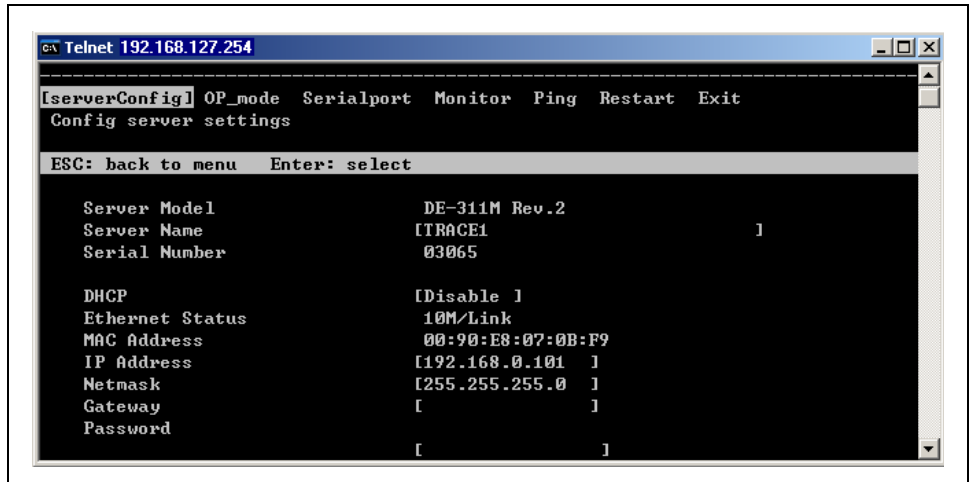

```

Telnet 192.168.127.254
-----
[serverConfig] OP_mode Serialport Monitor Ping Restart Exit
Config server settings
ESC: back to menu Enter: select

Server Model          DE-311M Rev.2
Server Name           [TRACE1          ]
Serial Number         03065

DHCP                  [Disable ]
Ethernet Status       10M/Link
MAC Address           00:90:E8:07:0B:F9
IP Address             [192.168.0.101  ]
Netmask               [255.255.255.0  ]
Gateway               [                ]
Password              [                ]

```

Use the **ARROWS** and **ENTER** keys to navigate the menus.

In this page you'll need to enter the new IP assigned needed for the LAN environment where the FOCUS GC LAN is installed. Also the netmask is entered in the same menu section.

In this example the IP set is 192.168.0.101, so when the setup procedure is completed, the FOCUS GC LAN will be communicating with a new IP.

Press **ESC** when the settings of this menu is over, to return to upper level menu.

Press the right arrow key to select **OP_mode**, and then press **ENTER**.

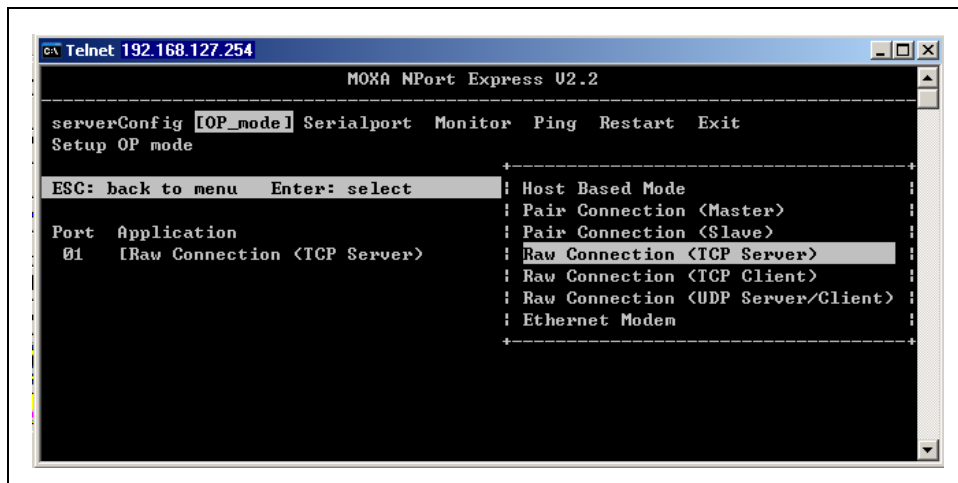

5. By moving the selection with the up/down arrow keys, select **Raw connection (TCP Server)** and then confirm with **ENTER**. Press **ESC** when done, to return to upper level menu. After selecting **Raw connection (TCP server)**, it will be possible to enter the **Select for more setting** menu and to enter a different TCP port rather than the default 4001.
6. Use the arrow key to select **Serial Port**.

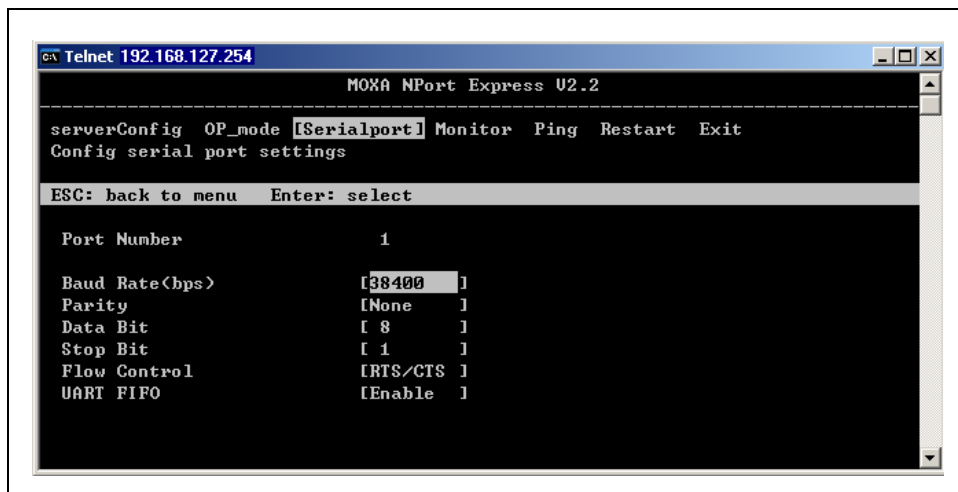

Make sure the **Serial port** is selected as follows:

Parameter	Set To:
Baud Rate	38400
Parity	None
Data Bit	8
Stop bit	1
Flow Control	RTS/CTS
UART FIFO	Enabled

Press **ESC** when done, to return to upper level menu

- When back to main menu, please select **Exit**.



```

Telnet 192.168.127.254
+-----+
| The configuration has been changed. Please press |
| <Enter> to reboot for new configuration or press |
| <ESC> to cancel.                               |
+-----+
| WARNING!!                                     |
+-----+
  
```



CAUTION Please confirm to make the changes effective, and remember that from now on, the FOCUS GC LAN will respond to the newly assigned IP Address.

- Disconnect the FOCUS GC from direct RED patch, and connect it to its final destination LAN environment.
At this point, as a final check, start from the computer that should be used for controlling the newly installed FOCUS GC and run **Command Prompt**. Then type **ping xxx.xxx.xxx.xxx**, where the xxx.xxx.xxx.xxx is the new IP you just configured.
The FOCUS GC LAN should answer as follows:

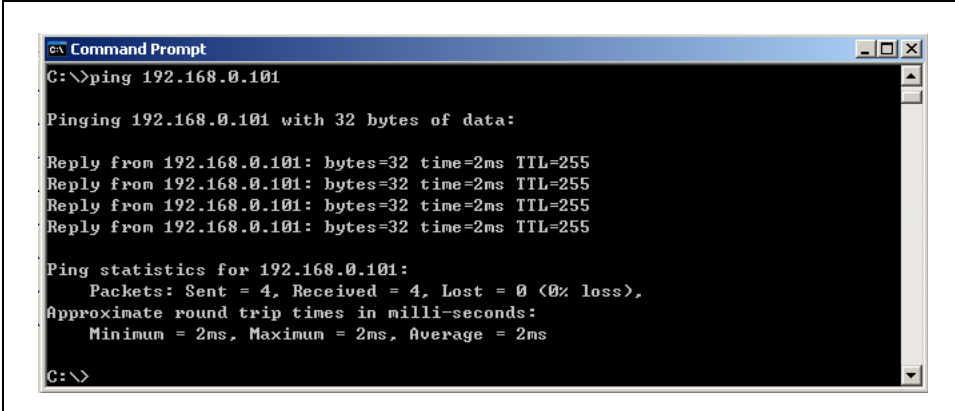

```
ex Command Prompt
C:\>ping 192.168.0.101

Pinging 192.168.0.101 with 32 bytes of data:

Reply from 192.168.0.101: bytes=32 time=2ms TTL=255
Reply from 192.168.0.101: bytes=32 time=2ms TTL=255
Reply from 192.168.0.101: bytes=32 time=2ms TTL=255
Reply from 192.168.0.101: bytes=32 time=2ms TTL=255

Ping statistics for 192.168.0.101:
    Packets: Sent = 4, Received = 4, Lost = 0 (0% loss),
    Approximate round trip times in milli-seconds:
        Minimum = 2ms, Maximum = 2ms, Average = 2ms

C:\>
```

The FOCUS GC is now ready for LAN control through the Thermo Fisher Scientific Corporation Data systems. Now it is necessary to configure the data system to access the FOCUS GC through the configured IP address.

The data systems that support the FOCUS GC LAN control are:

- Chrom-Card
- GC Link
- Xcalibur
- ChromQuest
- ChemStation

Data System Configuration

It is advisable to use the tags you find in the standard outfit of the FOCUS GC LAN.

A couple of self-adhesive labels are available to annotate the IP address and the TCP Port that have been set in the FOCUS GC LAN.

Please write on one of the label the two set parameters, and stick the label in a place that can be easily referenced when it will be necessary to configure the data system. The back of the instrument or the side cover may be suitable places where the label can be stuck.

9. Start the Data System and go to **Instrument configuration**. The FOCUS GC configuration page features the possibility to control the GC through the COM ports and to specify a direct TCP/IP address.

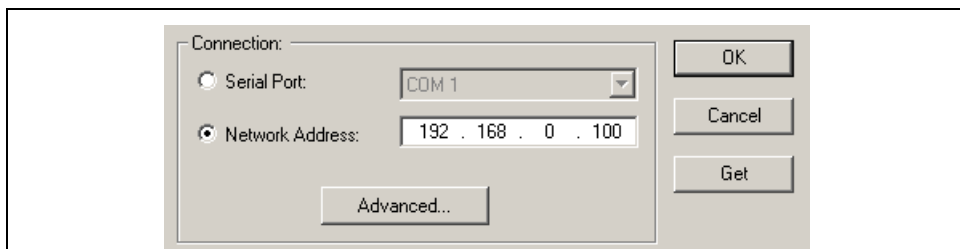

10. Enter the IP address of the FOCUS GC and complete the configuration in the usual way.

When the **ADVANCED** button is pressed, it is possible to set the communication port used by the TCP/IP protocol and the timeout.

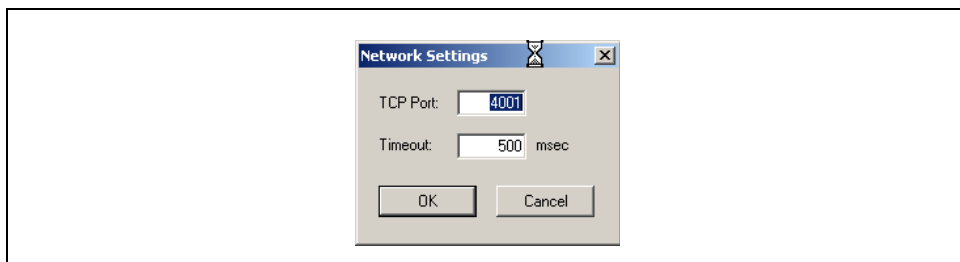

The parameters set by default are those necessary for standard operations; however your LAN may be provided with Firewall services that may prevent the Port 4001 to be used.

For this reason you have here the possibility to set an alternative port number. However, the number of the port entered in this box must correspond to the port assigned to FOCUS GC LAN setup described on step 9.

After selecting **Raw connection (TCP server)**, it will be possible to enter the **Select for more setting** menu and to enter a different TCP port rather than the default 4001.



WARNING! If the connection is performed through hubs over a 10 Mbit/s network, it is suggested that no more than 5 FOCUS GC LAN are connected on the same network trunk. In the case of switched network, this warning can be ignored.

Alternative Configuration

An alternative to the direct setup of the FOCUS GC LAN, it is also possible to use a management program designed for sites where multiple FOCUS GCs with LAN option are available. In this case a specific program must be installed and used to monitor, setup, or update each of the instruments connected.

The program to be installed is named **DSSETUP.EXE**, and available in the CD of the Chrom-Card data system, as well as in the CD of this manual.

1. Run the installation setup program DSSETUP.EXE:
2. Deselect the check box COM Port Mapping Tools, since it is not required in the management of FOCUS GCs.

Please just follow the detailed route proposed step-by-step by the installation program, and when finished, you can run the program. The first time after the installation the program starts automatically.

3. From main menu select the **Locate Server** and the program will automatically search for all FOCUS GCs connected to the network.

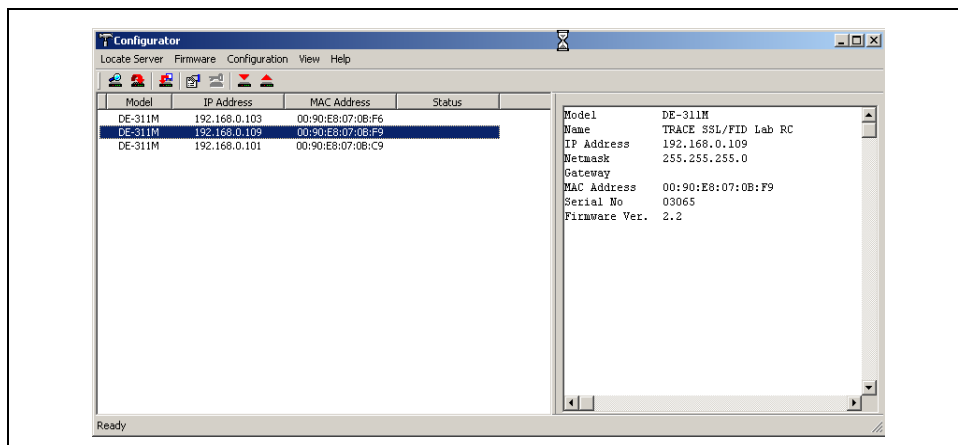

The program is a valid replacement of the step to step set up previously described in the document. By double-clicking on any of the found FOCUS GC, you can also setup it directly.

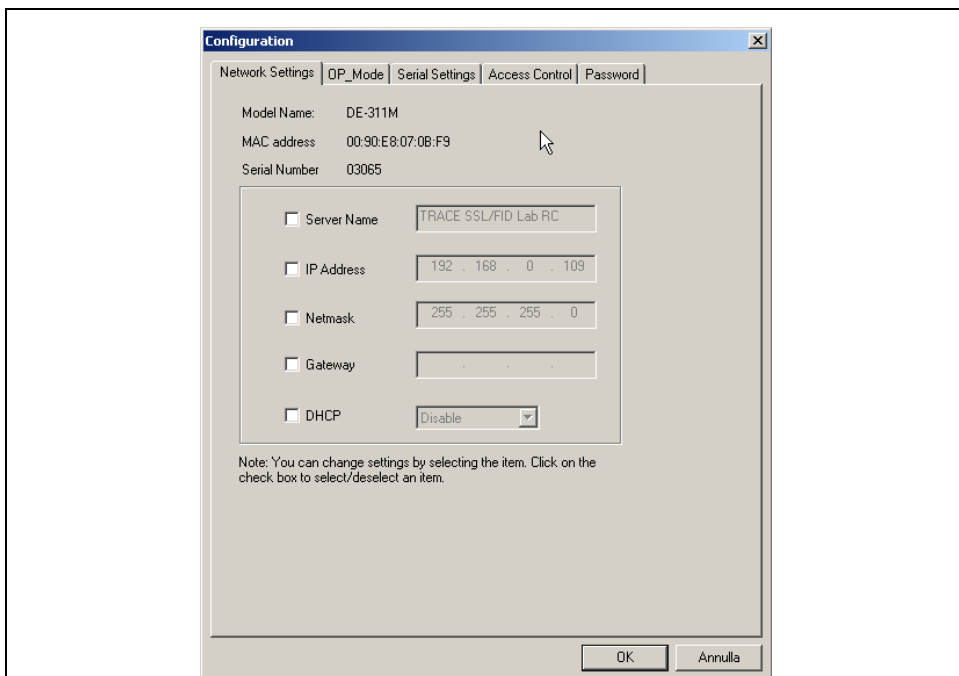

Any change can be entered individually for a certain parameter, and when OK is pressed, the parameter is updated to the instrument on edit.

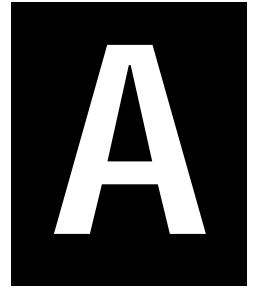

Customer Communication

Thermo Fisher Scientific provides comprehensive technical assistance worldwide and is dedicated to the quality of our customer relationships and services.

How To Contact Us

This appendix contains contact information for Thermo Fisher Scientific S.p.A office. Use the list reported in *Customer Communication* to contact your local Thermo Fisher Scientific office or affiliate.

Thermo Electron S.p.A
INTERNATIONAL SALES DEPARTMENT
Strada Rivoltana
20090 Rodano - Milano

Tel: +39 02 95059 226
Fax: +39 02 95059 256

Thermo Electron S.p.A
INTERNATIONAL CUSTOMER SUPPORT
Strada Rivoltana
20090 Rodano - Milano

Tel: +39 02 95059 373
Fax: +39 02 95059 225

This appendix also contains a one-page [Reader Survey](#). Use this survey to give us feedback on this manual and help us improve the quality of our documentation

Reader Survey

Product: FOCUS GC
Manual: Instruction Manual
Part No.: 317 094 12

Please help us improve the quality of our documentation by completing and returning this survey.
 Circle one number for each of the statements below.

	Strongly Agree	Agree	Neutral	Disagree	Strongly Disagree
The manual is well organized.	1	2	3	4	5
The manual is clearly written.	1	2	3	4	5
The manual contains all the information I need.	1	2	3	4	5
The instructions are easy to follow.	1	2	3	4	5
The instructions are complete.	1	2	3	4	5
The technical information is easy to understand.	1	2	3	4	5
Examples of operation are clear and useful.	1	2	3	4	5
The figures are helpful.	1	2	3	4	5
I was able to install the system using this manual.	1	2	3	4	5

If you would like to make additional comments, please do. (Attach additional sheets if necessary.)

Fax or mail this form to:

Thermo Electron S.p.A.
 Strada Rivoltana km 4
 20090 Rodano (MI)
 ITALY
 Fax: 39 02 95059388

This section contains an alphabetical list and descriptions of terms used in this guide and the help diskette. It also includes abbreviations, acronyms, metric prefixes, and symbols.

A

A	ampere
ac	alternating current
ADC	analog-to-digital converter

B

b	bit
B	byte (8 b)
baud rate	data transmission speed in events per second

C

°C	Celsius
CIP	Carriage and Insurance Paid To
cm	centimeter
CPU	central processing unit (of a computer)
CSE	Customer Service Engineer

D

d	depth
DAC	digital-to-analog converter
dc	direct current
DS	data system

E

EMC	electromagnetic compatibility
-----	-------------------------------

Glossary

ESD	electrostatic discharge
F	
°F	Fahrenheit
FID	Flame Ionization Detector
FOB	Free on Board
ft	foot
G	
g	gram
gain	A measure of the ability of an electronic circuit or device to increase the magnitude of an electronic input parameter.
GC	gas chromatograph
GND	electrical ground
H	
<i>h</i>	height
h	hour
harmonic distortion	A high-frequency disturbance that appears as distortion of the fundamental sine wave.
HV	high voltage
Hz	hertz (cycles per second)
I	
ID	inside diameter
IEC	International Electrotechnical Commission
impulse	See <i>transient</i>

in	inch
I/O	input/output
K	
k	kilo (10^3 or 1024)
K	Kelvin
kg	kilogram
kPa	kilopascal
L	
l	length
l	liter
LAN	Local Area Network
lb	pound
LED	light-emitting diode
M	
m	meter (or milli [10^{-3}])
M	mega (10^6)
μ	micro (10^{-6})
MBq	megabecquerel
mCi	millicurie
meniscus	The curved upper surface of a column of liquid.
min	minute
mL	milliliter
mm	millimeter

Glossary

m/z	mass-to-charge ratio
N	
n	nano (10^{-9})
negative polarity	The inverse of a detector signal polarity.
nm	nanometer
O	
OD	outside diameter
Ω	ohm
P	
p	pico (10^{-12})
Pa	pascal
PCB	printed circuit board
PN	part number
PPKD	Purged Packed Injector
psi	pounds per square inch
R	
RAM	random access memory
RF	radio frequency
ROM	read-only memory
RS-232	industry standard for serial communications
S	
s	second

S/SL	Split/Splitless Injector
sag	See <i>surge</i>
slow average	A gradual, long-term change in average RMS voltage level, with typical durations greater than 2 s.
source current	The current needed to ignite a source, such as a detector lamp.
surge	A sudden change in average RMS voltage level, with typical duration between 50 μ s and 2 s.
T	
TCD	Thermal Conductivity Detector
TFS	Thermo Fisher Scientific
transient	A brief voltage surge of up to several thousand volts, with a duration of less than 50 μ s.
V	
V	volt
V ac	volts, alternating current
V dc	volts, direct current
VGA	Video Graphics Array
W	
w	Width
W	Watt

NOTE The symbol for a compound unit that is a quotient (for example, degrees Celsius per minute or grams per liter) is written with a negative exponent with the denominator. For example:

Glossary

$^{\circ}\text{C min}^{-1}$ instead of $^{\circ}\text{C/min}$
 g L^{-1} instead of g/L

A

- About This Manual xiii
 - Conventions Used xv
 - Overview xiii
- Acceptance Criteria
 - CHROM-CARD 256
 - CHROMQUEST 241, 256
 - Computing-integrator (e.g. ChromJet) 241
- Air 219
- Analytical Acceptance Comments 228, 241, 256
- Analytical Column 218, 232, 246
- Analytical Conditions Required for Splitless
 - Injection 220, 234, 249
- Analytical Problems 309
- Analytical Unit 26
- Autosampler
 - Interface 30

B

- Base Temperature 219, 233, 248

C

- Carrier Gas 219, 233, 248
- Carrier Gas Control 27
- Checkout 215, 229, 243
 - FID-S/SL 220, 234, 249
 - TCD-PPKD 249
 - TCD-S/SL 234
- Checkout Using FID with S/SL 215
 - Analytical Conditions Required for Splitless
 - Injection 219
 - Parts Referenced 218
- Checkout Using TCD with PPKD 243
 - Analytical Conditions Required for Splitless
 - Injection 248
 - Parts Referenced 246
- Checkout Using TCD with S/SL 229
 - Analytical Conditions 233
 - Analytical Conditions Required for Splitless
 - Injection 233
 - Parts Referenced 232
- ChromQuest 218
- Cleaning xxiv, 261
- Cleaning the unit 27
- Collecting Electrode

- Cleaning

- 288

- Replacement 288

- Column Conditioning 217, 231, 245

- Column Evaluation 217, 231, 245

- Column Installation 217, 231, 245

- Column Leak Check 217, 231, 245

- Column Oven 26, 28

- Columns 29

- Fittings 126

- Ferrules 126

- Retaining Nuts 127

- Constant Filament Temperature 233, 248

- Constant Septum Purge 219, 233

- Controlling Valves 206

- Conventions Used xv

D

- Data Acquisition 218, 232, 247
- Data Handling Connections 216, 230, 244
- Data Systems Interface 30
- Decontaminating the unit 27
- Decontamination xxiv
- Deleting a Run Time Event 205
- Detector 29, 219, 233, 248
- Detector base body 162
- Detector compartment 26
- Detector Connections 217, 231, 245
- Detector side adapter 246
- Detector Signal Range 219
- Display 27, 42
- Display and Keypad 27
- Display LEDs 44
- Dodecane 218, 232, 247
- DPFC Module 27
- Drift 227, 241, 256

E

- Editing Run Time Events 202
- Electronic Compartment 27
- Electronic compartment 27
- Error Messages 307
- Exterior
 - cleaning xxiv
- External Devices

Index

- Autosamplers 31
- F**
- FID
 - External Detector Gases Flow Regulation 76
 - FID Installation 162
 - FID Troubleshooting 295
 - FID-S/SL
 - Analytical Acceptance Criteria 227, 241, 256
 - FID-S/SL Acceptance Criteria 227
 - CHROM-CARD 227
 - CHROMQUEST 227
 - Computing-integrator (e.g. ChromJet) 227
 - FID-S/SL Analytical Conditions 219, 233, 248
 - FID-S/SL Checkout in Splitless Mode 220, 234, 249
 - FID-S/SL Parts Referenced 218, 232, 246
 - FID-SSL Analytical Conditions 219, 233, 248
 - FID-SSL Checkout in Splitless Mode 220, 234, 249
 - Filament Temperature limit 233, 248
 - Filament Voltage 233, 248
 - Final Temperature 219, 233, 248
 - Final Time 219, 233, 248
 - Flame Ionization Detector 157
 - Gases 161
 - Jet 159
 - Menu 164
 - Selectivity 160
 - Temperature 160
- FOCUS GC
 - Components 26
 - Description 25
 - Document Set xx
 - Instrument
 - Overview 26
- G**
- Gain 233, 248
- Gas Control 27
 - Carrier 27
 - Detector 28
- Gas Sampling Valve
 - Maintenance 304
 - Overview 40
 - Sample In/Out Ports 37
 - Servo air 36
- Gas Supply Connections 216, 230, 244
- Gases 218, 219, 232, 233, 247, 248
- Getting Started 197
- Glass Liner 218, 232, 246
 - Breakage 263
- Glass Liner Installation 216, 230, 244
- Ignition polarization cable 163
- Graphite ferrule for 0.32 mm ID Column 218, 232, 246
- Graphite seal for glass liner 218, 232, 246
- Guide to Solve Analytical Problems 309
- H**
- Hazardous material
 - decontamination xxiv
 - spills xxiv
- Helium 219, 233, 248
- Hexadecane 218, 232, 247
- High-voltage compartment 27
- Hot Empty Needle Injection 101, 106
- How to Control Valve 206
- How To Perform Maintenance 259
- How to Setting Up the Instrument 198
- How to Starting Up the Instrument 208
- Hydrogen 219
 - Sensor
 - Use xxiv
 - Use xxiii
- Hydrogen Sensor xxiv
- I**
- Ignition Assembly
 - Replacement 292
- Initial Temperature 219, 233, 248
- Initial Time 219, 233, 248
- Injected Volume 219, 233, 248
- Injection side adapter 246
- Injector 28, 219, 233, 248
- Injector compartment 26
- Instrument
 - Automation 30
 - Classification xxi
 - Markings xviii
 - Symbols xviii
- Instrument Automation 30

Instrument Cleaning 261
 Instrument Set-up 198
 Instrument Start-Up 208
 Instrument Troubleshooting 307

J

Jet 162
 Cleaning 284
 Replacement 284
 jet 162

K

Keypad 27, 45

L

Lamp Current 233, 248
 LAN Option 38
 Reset Button 323
 LAN Setup
 Communication Port 322
 IP Address 322
 Network Cables 323
 Leak Test 218, 232, 246
 LEDs
 Display 44
 Not Ready/Error 44
 Standby/Prep Run 44
 Liner 99
 Cleaning 262
 Replacing 262
 Liner Seal 218, 232, 246

M

Maintanance
 SSL Injector 262
 Maintaning Gas Sampling Valve 304
 Maintenance 257, 259
 FID 282
 PPKD Injector 276
 Schedule Table 260
 Suggested Schedule 259
 TCD 298
 Make-up 233, 248
 Make-up Gas 219
 Markings xviii

Material Safety Data Sheets xxiv
 Messages 211
 Methods and Sequences 31

N

Negative Polarity 233, 248
 Network Cables 323
 Nitrogen 219, 233, 248
 Noise 227, 241, 256
 Not Ready/Error LED 44

O

Operating Mode 219, 233, 248
 Operating Procedure 217, 231, 245
 Oven Program 219, 233, 248

P

Packed Column Injector
 Septum 119
 Pneumatic Compartment 26
 Pneumatic compartment 26
 PPKD
 Liner
 Cleaning 279
 Replacement 279
 Septum
 Replacement 277
 PPKD. *See* Purged Packed Column Injector
 Press-fit connections 246
 Purged Packed Column Injector 113
 Injection Technique 116
 Liners 116
 Menu 116
 Overview 114
 Programming 120, 121, 122, 123
 Septa 116

R

Ramp 1 219, 233, 248
 Reference Gas 233, 248
 Registration and Revision Number 216, 230, 244
 Replace the PPKD Septum 277
 Replace the Standard Septum 264
 Run Time Events 202

Index

S

S/SL. *See* Split/Splitless Injector
Safety Information xxii
 Use of Gases xxii
safety symbols xv–xix
Septum 99, 218, 232, 246
Septum Installation 216, 230, 244
Servo Air 36
Sheath Gas 233, 248
Signal cable 163
Solve Analytical Problems 309
SOP
 Analytical Conditions 219, 248
 FID-Splitless Injection 226, 240, 255
 Parts Referenced 218, 232, 246
 Preliminary Operation 216, 230, 244
 Scope 216, 230, 244
Split Flow 219, 233
Split Mode 110
Split/Splitless Injector 93
 Liners 97
 Menus 99
 Overview 94
 Packed Columns 98
 Septum 97
 Split Injection Technique 101
 Splitless Injection Technique 103
 flooding 106
 sample refocusing 105
 solvent effect 105
Splitless Mode 111
Splitless Time 219, 233
Standard 216, 230, 244
Standard Operating Procedures 216, 230, 244
Standard Septum
 Cleaning 267
 Replacement 264, 267
 Replacing 262
Standby/Prep Run LED 44
Status Panel 27
Surge Splitless Mode 112
Symbols xviii
Syringe 218, 232, 246

T

TCD
 Detector Gases Flow Regulation 77
 Troubleshooting 300
TCD. *See* Thermal Conductivity Detector
TCD-PPKD Acceptance Criteria 256
 CHROM-CARD 256
 CHROMQUEST 256
 Computing-integrator (e.g. ChromJet) 256
TCD-S/SL Acceptance Criteria 241
 CHROM-CARD 241
 CHROMQUEST 241
 Computing-integrator (e.g. ChromJet) 241
TCD-S/SL Analytical Conditions 233
Technical Features xxi
Temperature 219, 233, 248
Test Mixture 218, 232, 247
Tetradecane 218, 232, 247
Thermal Conductivity Detector 171
 Columns 175
 Gases
 Supplies 174
 High Thermal Conductivity Gases
 Operating Modes
 Constant Temperature 177
 Constant Voltage 177
 Menu 179
 Modes 175
 Automatic Switching 176
 to Constant Current 176
 Constant Current 176
 Constant Temperature 175
 High Thermal Conductivity Gases 177
 Constant Voltage
 High Thermal Conductivity Gases 177
 Overview 172
 Programming
 with Non-DGFC 182
 Selecting Operating Parameters 177
 Shut Down 185
 Signal Parameters 184
Tool for jet 162
Troubleshooting 257, 306
 FID 295
 Instrument 307

Troubleshooting the TCD 301

U

Use of Gases xxii

User Interface 27, 41, 42

Using Hydrogen xxiii

Using the Hydrogen Sensor xxiv

W

Wander 227, 241, 256

X

Xcalibur 218

Operating Sequences

Configuring the Carrier Gas	73
Configuring The Pressure Unit	74
Measuring the Detector Gas Flows with a Bubble Meter	78
Configuring the Column Oven	86
Setting Up a Single Ramp Temperature Program	89
Setting Up Multiple Ramp Temperature Program	90
Installing a Liner and a Septum	99
Programming the Split Mode	110
Programming the Splitless Mode	111
Programming the Surge Splitless Mode	112
Replacing a Septum	119
Programming the PPKD Injector Wide bore Mode	120
Programming the PPKD Injector Surged Wide bore Mode	121
Programming the PPKD Injector Packed Mode	122
Programming the PPKD Injector Surged Packed Mode	123
How to Connect a Capillary Column	132
How to Connect a Packed Column	138
Manual Checking for Leaks	147
Performing a Column Evaluation	148
Performing an Automatic Leak Check	154
Programming a FID	167
Setting the FID Signal Parameters	169
Programming a TCD	182
Setting the TCD Signal Parameters	184
Shutting Down the TCD	185
How to Set Up the Instrument	198
Editing Run Time Events	202
Deleting a Run Time Event	205
How to Start Up the Instrument	208
FID-S/SL Checkout in Splitless Mode	220
TCD-S/SL Checkout in Splitless Mode	234
TCD-PPKD Checkout	249
Replace the S/SL Standard Septum	264
Replace or Clean the Liner when a S/SL Standard Septum is Installed	267
Replace the S/SL Inlet Vent Line Filter	273
Replace the PPKD Septum	277

Replace or Clean the PPKD Liner	279
Clean/Replace the FID Jet	284
Clean/Replace the FID Collecting Electrode	288
Replace the FID Ignition Assembly	292
How to Install/Replace the Loop of an Automatic Valve	304



List of Figures

FOCUS GC Components	26
FOCUS GC Front Panel	31
Column Oven Internal View	32
FOCUS GC User Interface	32
Example of Electronic Compartment	33
Rear Panel	35
Electrical Connections	37
Top Panel	39
Gas Sampling Valve	40
The FOCUS GC User Interface	42
Components of the FOCUS GC Menu Display	43
FID-External Detector Gases Flow Regulation.	76
TCD Detector Gases Flow Regulation	77
The FOCUS GC Column Oven	84
Example of Single Ramp Temperature Program	89
Example of Multiple Ramp Temperature Program	90
Split/Splitless Injector	94
Septum Purge System	95
Split/Splitless Injector Components	96
S/SL with a Packed Column	98
Split Injection Technique	102
Splitless Injection Technique	104
Purged Packed Column Injector	114
PPKD Injector Components	115
Capillary/Wide Bore Column to Injector and Detector Base Body Connections	127
Metric Packed Column Fittings	129
Injector and Detector Base Body Adapters	130
Conversion Kit	131
Metal Packed Column Fittings	138
Removing the S/SL Injector Top Components	140
Removing the S/SL Injector Bottom Components	141
Metal Adapter Installation	141
Graphite Seal Installation Tool	142
Reinstalling the S/SL Injector Top Components	143
Connecting the Packed Column	143
Flame Ionization Detector	158
FID Detector Base Body and DGFC Module	159

Jet for FID	162
Installation of the FID	163
TCD Filaments and Gas Flows	173
Manual Zero-adjustment	185
FID-Splitless Injection	226
TCD-Splitless Injection	240
TCD-PPKD Injection	255
Replace the Septum	265
Replace and Clean the Liner (1)	268
Replace a Broken Liner	270
Replace and Clean the Liner (2)	271
Replace and Clean the Liner (3)	272
Top Aluminium Cover Removal (1)	273
FOCUS GC Rear Panel	274
Filter Replacing	275
PPKD Injector Septum Replacement	278
PPKD Injector Replace/Clean the Liner	280
FID Parts Identification	283
Clean/Replace the Jet (1)	285
Clean/Replace the Jet (2)	286
Clean/Replace the Jet (3)	287
Clean/Replace the Jet (4)	287
Clean/Replace the Collecting Electrode (1).	289
Clean/Replace the Collecting Electrode (2)	290
Clean/Replace the Collecting Electrode (3)	291
Replace the Ignition Assembly (1)	293
Replace the Ignition Assembly (2)	293
TCD Components	299
Top Aluminium Cover Removal	304
GSV Sampling Loop	305
Sampling Loop Installation/Replacing	305

List of Tables

Status LED Descriptions	44
Keypad Descriptions	45
Configuration Menu	52
Configure Oven Menu	53
Configure Carrier Menu	54
Configure AS 2000 Autosampler Menu	56
Configure AI 3000/AS 3000 Autosampler Menu	57
General Config Menu	58
Configure Keyboard & Display Menu	59
Beep Table	59
Configure Handshake Menu	60
Configure Time Menu	61
Configure Valves Menu	62
Edit Time Event Menu	63
Valves	68
Info/Diagnostics	69
Carrier Gas Parameters Menu	81
Oven Parameters Menu	87
Liner Sizes and Applications	97
Inlet Modes	107
Inlet Parameters Menu	108
Inlet (PPKD) Menu	118
Ferrules	127
Metric Packed Column Fittings	128
Imperial Size Packed Column Fittings	130
FID Parameters	164
FID Signal Parameters	166
Thermal Conductivity of Gases	174
Filament Temperature Values for Argon	178
Selectable TCD Parameters	178
The Detector (TCD) Parameters	179
TCD Signal Parameters	181
AS 2000 Autosampler Menu	190
Internal Standard Menu	192
AI 3000/AS 3000 Menu	193
Sequence Menu	195
FID-S/SL Parts Referenced	218

FID-S/SL Analytical Conditions	219
FID-S/SL Acceptance Criteria	227
TCD-S/SL Parts Referenced	232
TCD-S/SL Analytical Conditions	233
TCD-S/SL Acceptance Criteria	241
TCD-PPKD Parts Referenced	246
TCD-PPKD Analytical Conditions	248
TCD-PPKD Acceptance Criteria	256
Standard Maintenance Schedule	260
Gases used for FID	295
Gas for FID Flow Rates	295
Difficulty in Igniting the Flame	296
TCD Troubleshooting Table	301
Error Messages	307

