

**SYSTEM CONTROLLER
FOR SHIMADZU HIGH PERFORMANCE
LIQUID CHROMATOGRAPH
CBM-20A/20Alite
INSTRUCTION MANUAL (brief manual)**

Read the instruction manual thoroughly before you use the product.
Keep this instruction manual for future reference.



This page is intentionally left blank.

Instruction Manuals

There are 2 instruction manuals for this instrument.

Use the appropriate one depending upon your specific needs.

■ CBM-20A Instruction Manual (brief manual)

This document. First read through this.

This volume contains the basic methods of use, warnings, and maintenance notices.

■ CBM-20A Instruction Manual (detailed manual) [PDF Instruction Manual]

The CD-ROM provided with this product contains the detailed Instruction Manual in PDF file format. The detailed Instruction Manual contains information on application operations, error messages, installation, validation, etc. For the detailed operation method, information concerning a particular error message, or any information not contained in the brief manual, please refer to the detailed Instruction Manual in PDF form.

The PDF file of the Instruction Manual can be found at <CD-ROM drive:\Manual\EN> folder.

Open the PDF file using the Adobe Reader. The Adobe reader can be downloaded from the Adobe Systems Inc. homepage <http://www.adobe.com>.

■ Installing Internet Explorer

Internet Explorer version 6 SP1 or higher is required. If your PC operating system is Windows 2000 or the version of Internet Explorer is lower than 6 SP1, it is mandatory that you upgrade your Internet Explorer. Download Internet Explorer version 6 SP1 from the Microsoft homepage <http://www.microsoft.com/>. The program can also be installed by using the program contained in the folder <CD-ROM drive:\Internet Explorer\WIN32\EN>.

■ Content of the CD-ROM

The files contained on the CD-ROM are as shown in the following table.

Folder	File	Description
<Internet Explorer>		
<WIN32>		
<EN>		Internet Explorer 6 SP1 English
<JP>		Internet Explorer 6 SP1 Japanese
<Manual>		
<EN>	<ul style="list-style-type: none">• CBM-20A_Brief_en.pdf• CBM-20A_Detail_en.pdf• CBM-20A_iPadSetupManual_en.pdf• QuickGuideforConnectionofCBM-PDA_en.pdf	<ul style="list-style-type: none">• Instruction Manual (brief manual) English• Instruction Manual (detailed manual) English• iPad Connection Setup Manual English• Quick Guide for Connection English
<JP>	<ul style="list-style-type: none">• CBM-20A_Brief_jp.pdf• CBM-20A_Detail_jp.pdf• CBM-20A_iPadSetupManual_jp.pdf• QuickGuideforConnectionofCBM-PDA_jp.pdf	<ul style="list-style-type: none">• Instruction Manual (brief manual) Japanese• Instruction Manual (detailed manual) Japanese• iPad Connection Setup Manual Japanese• Quick Guide for Connection Japanese

■ Model Names

- The autosampler for LC-20A (Prominence) series includes models with model names ending in HT or other letters (such as SIL-20AHT and SIL-20ACHT UFLC). These models are the same as their normal version (such as SIL-20A and SIL-20AC), but with some of their functionality or specifications modified. However, unless an exception is specifically indicated, the CBM-20A/20Alite Instruction Manual will refer to them by the model name of their respective normal versions. For example, models SIL-20A, SIL-20AHT, and SIL-20AHT UFLC are collectively referred to as model SIL-20A.

Model names indicated in windows including the system configuration window or method settings window are also referred to by their respective normal version model names. For example, if a system includes model SIL-20AHT, the model name indicated in the system configuration window will be SIL-20A.

- The autosampler for LC-20A (Prominence, Nexera XR) series includes models SIL-20A, SIL-20AC, SIL-20AXR, and SIL-20ACXR. The CBM-20A/20Alite Instruction Manual may refer to these autosamplers as "LC-20A series autosamplers" or "SIL-20A series autosamplers".
- The solvent delivery pump for LC-20A (Prominence, Nexera XR) series includes models LC-20AB, LC-20AD, LC-20ADX, LC-20AT, LC-20AP, LC-20AR and LC-20Ai. The CBM-20A/20Alite Instruction Manual may refer to these pumps as "LC-20A series pumps".
- The autosampler for LC-30A (Nexera X2, Nexera UC) series includes models SIL-30AC, SIL-30ACMP, and SFE-30A. The CBM-20A/20Alite Instruction Manual may refer to these autosamplers excluding the SFE-30A as "LC-30A series autosamplers" or "SIL-30A series autosamplers".
- The solvent delivery pump for LC-30A (Nexera X2, Nexera UC) series includes models LC-30AD and LC-30ADSF. In the CBM-20A/20Alite Instruction Manual, "LC-30A series pumps" refers to the LC-30AD (excluding the LC-30ADSF).

Introduction

Read this manual thoroughly before using the instrument.

Thank you for purchasing this instrument. This manual describes: the installation, operation, hardware validation, cautions for use, and details on the accessories and options. Read the manual thoroughly before using the instrument. Use the instrument in accordance with the manual's instructions. Keep this manual for future reference.

When connecting a component to this instrument, first thoroughly read the instruction manual for that component, and proceed according to the contents of the instruction manual.

For installation information, details of operation methods and warnings regarding use, hardware validation, and accessories and options for this instrument, refer to the Instruction Manual (detailed manual) contained on the CD-ROM.

Original version is approved in English.

IMPORTANT

- If the user or usage location changes, ensure that this Instruction Manual is always kept together with the product.
- If this manual or a product warning label is lost or damaged, immediately contact your Shimadzu representative to request a replacement.
- To ensure safe operation, read all **Safety Instructions** before using the product.
- To ensure safe operation, contact your Shimadzu representative if product installation, adjustment, or re-installation (after the product is moved) is required.

COPYRIGHT

- This publication may not be reproduced in whole or in part without written permission from Shimadzu Corporation. Since Shimadzu products are frequently upgraded and improved, information in this publication is subject to change without notice. We appreciate notification of any errors or omissions.

Adobe, the Adobe logo, and Reader are either registered trademarks or trademarks of Adobe Systems Incorporated in the United States and/or other countries.

Intel and Celeron are either registered trademarks or trademarks of Intel Corporation in the United States and/or other countries.

Windows is either a registered trademark or trademark of Microsoft Corporation in the United States and/or other countries.

iPad is a trademark of Apple Inc., registered in the U.S. and other countries.

© 2004-2017 Shimadzu Corporation. All rights reserved.

Warranty and After-Sales Service

Warranty

1. Validity

Please consult your Shimadzu representative for information about the extent of the warranty.

2. Term

The manufacturer will provide free replacement parts for, or repair free of charge, any instrument that fails during the warranty period, if the cause can be attributed to a defect in manufacturing.

3. Limitation of Liability

- 1) In no event will Shimadzu be liable for any lost revenue, profit or data, or for special, indirect, consequential, incidental or punitive damages, however caused regardless of the theory of liability, arising out of or related to the use of or inability to use the product, even if Shimadzu has been advised of the possibility of such damage.
- 2) In no event will Shimadzu's liability to you, whether in contract, tort (including negligence), or otherwise, exceed the amount you paid for the product.

4. Items Not Covered by the Warranty

The warranty does not cover malfunctions that result from:

- 1) misuse;
- 2) repairs or modifications made by any company other than the manufacturer or an approved company;
- 3) external factors;
- 4) operation under severe conditions such as environments, with high temperature, high humidity, corrosive gas, vibration, etc.;
- 5) fire, earthquake or other forces of nature;
- 6) moving or transporting the instrument after its initial installation;
- 7) the consumption of items or parts that can be regarded as consumable. (For example, the service life of an LCD display panel depends on the actual operating conditions.)

After-Sales Service

If any problem occurs with this instrument, inspect it and take appropriate corrective action as described in the Section "[5 Maintenance](#)" and Instruction Manual (detailed manual) "[6 Troubleshooting](#)". If the problem persists, or symptoms not covered in the Troubleshooting section occur, contact your Shimadzu representative.

Replacement Parts Availability

Replacement parts for this instrument will be available for a period of seven (7) years after the discontinuation of the product. Thereafter, such parts may cease to be available. Note, however, that the availability of parts not manufactured by Shimadzu shall be determined by the relevant manufacturers.

Hardware Validation

Each LC component and the entire LC system should be checked periodically to ensure that they function normally, or the analysis data may not be reliable. To this end, it is necessary to carry out periodic hardware validation and keep records of the validation. There are two types of hardware validation - component validation and system validation. The purpose of component validation is to check that the individual components of the system function normally, while the system validation checks that the system as a whole (the several components in combination) functions normally.

Before shipment from the factory, this instrument was rigorously inspected. The results are summarized in the Inspection certificate accompanying the instrument. To inspect the instrument performance after installation, repeat the Hardware Validation as described in "7 Hardware Validation".



 *the Instruction Manual (detailed manual) "7 Hardware Validation"*

Hardware Validation Contract

This is a contract under which a qualified Shimadzu-approved engineer performs periodic component and system validation, and provides reports of the results. Details of the contract can be obtained from your Shimadzu representative.

Safety Instructions

- To ensure safe operation of the instrument, read these Safety Instructions carefully before use.
- Observe all of the WARNINGS and CAUTIONS described in this section. They are extremely important for safety.
- In this manual, warnings and cautions are indicated using the following conventions;

 WARNING	Indicates a potentially hazardous situation which, if not avoided, could result in serious injury or possibly death.
 CAUTION	Indicates a potentially hazardous situation which, if not avoided, may result in minor to moderate injury or equipment damage.
	Emphasizes additional information that is provided to ensure the proper use of this product.

■ Application Precautions

 WARNING This instrument is a system controller for use with a high performance liquid chromatography system. Use this instrument ONLY for the intended purpose. Using this instrument for any other purpose could cause accidents.
--

■ Installation Site Precautions

⚠ WARNING

- **The solvents used in high performance liquid chromatograph are flammable and toxic. The room where the instrument is installed should be well ventilated;** otherwise, solvent vapors could cause poisoning or ignite and cause a fire.

- **High performance liquid chromatograph uses large amounts of flammable organic solvents. Use of open flame in the vicinity of this instrument must be strictly prohibited. Do not install the instrument in the same room with any other equipment that emits or could potentially emit sparks, since sparks could cause a fire.**

Provide fire extinguishers for use in case of fire.

- **Provide protective equipment near the instrument.**

If solvent gets into the eyes or on the skin, it must be flushed away immediately. Provide equipment, such as eye wash stations and safety showers, as close to the instrument as possible.

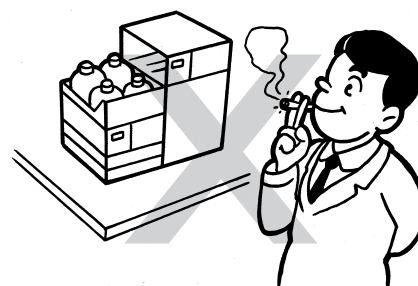
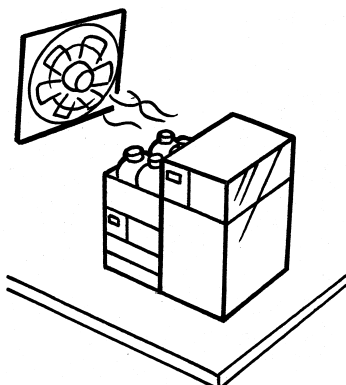
**⚠ CAUTION**

- **The weight of the CBM-20A is 5.5 kg. During installation, consider the entire weight combined with other LC components.**

The lab table on which this instrument is installed should be strong enough to support the total weight of the LC system. It should be level, stable and have depth of at least 600 mm.

Otherwise, the instrument could tip over or fall off the table.

- **Keep at least 100 mm between the rear of the instrument and the wall.**

This allows for sufficient air circulation and ventilation from the grille to provide cooling and prevent the instrument from overheating and impairing the performance.

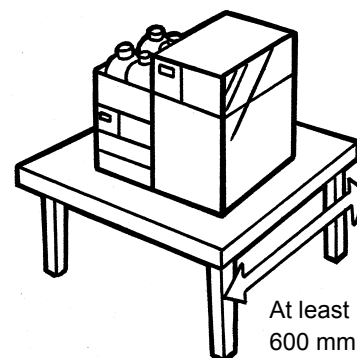

CAUTION

- **Avoid installation sites that are exposed to corrosive gases or excessive dust.**

These adverse conditions may be detrimental to maintaining the instrument performance and may shorten its service life.

■ Installation Precautions

To ensure safe operation, contact your Shimadzu representative if product installation, adjustment, or re-installation (after the product is moved) is required.

WARNING

- **Take measures to prevent the instrument from falling in the event of an earthquake or other disaster.**

Strong vibrations could cause the instrument to fall over, resulting in injury.

- **The power supply voltages and power consumptions of this instrument are listed below. The power supply voltage of the instrument is indicated on the label on the back of the instrument. Connect the instrument to a power supply that complies with the capacity and use a power cord that complies with the capacity;**

otherwise, fire or electric shock could result. Check that the power supply voltage is stable and that its current capacity is sufficient to operate all the components of the system. If not, the instrument will not operate at its rated performance. When using CBM-20Alite, refer to the instruction manuals of the incorporated instruments for power supply voltages and power consumptions.

CBM-20A

Part No.	Power Supply Voltage ¹ (indicated on the instrument)	Power Consumption	Frequency	Rated Breaking Capacity ²
S228-45012-31 /41	AC 100-120 V (100-120 V~)	400 VA ³	50-60 Hz	40A
S228-45012-32 /42	AC 100-120 V (100-120 V~)	400 VA ³	50-60 Hz	40A
S228-45012-38 /46/48/58	AC 220-240 V (220-240V~)	400 VA ³	50-60 Hz	40A

1: Mains supply voltage fluctuations are not to exceed 10 % of the nominal supply voltage.

2: Connect the instrument to a power outlet that is equipped with a circuit breaker that shuts off the current at the described value or less.

3: If the AC output connectors are not used, this value is 100 VA.

- **Ground the instrument.**

Grounding is necessary to prevent electric shock in the event of an accident or electrical discharge, and important for ensuring stable operation.

- **To prevent electric shock and to maintain stability in operation of the product, be sure to ground the product.**

The product will be grounded when the provided 3-wired power plug is inserted into a 3-wired power socket equipped with a ground terminal.

- **Do not place heavy objects on the power cord, and keep any hot items away.**

The cord could be damaged, resulting in fire, electrical shock or malfunction. If the cord becomes damaged, contact your Shimadzu representative immediately.

- **Do not modify the cord in any way. Do not bend it excessively or pull on it.**

The cord could be damaged, resulting in fire, electrical shock or malfunction. If the cord becomes damaged, contact your Shimadzu representative immediately.

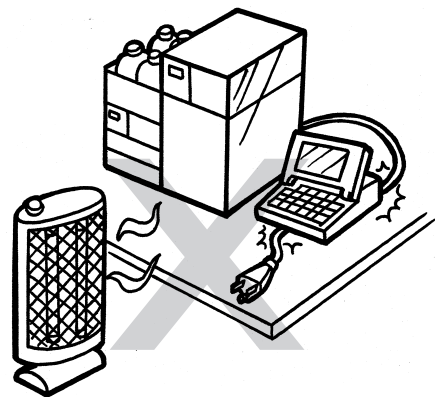

CAUTION

- **When installing the instrument, be careful not to pinch your fingers between the system components, as this could result in injury.**

- **When opening the doors, be careful not to pinch your fingers as this could result in injury.**

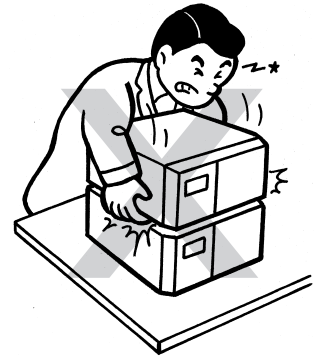

■ Operation Precautions

⚠ WARNING

- **Take thorough measures to prevent buildup of static electricity.**

Static electricity could result in fires or explosions.

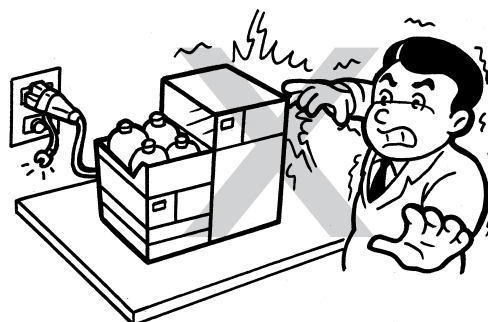

- **Always wear protective gloves and protective goggles when handling solvents and samples.**

If solvent gets into the eyes, blindness could result. Should solvent get into the eyes, flush immediately with large amounts of water and get medical attention.



- **Always wear protective gloves when handling any toxic or biologically infectious samples.**

- **Never use a cracked reservoir bottle.**

If a helium degassing unit is used, pressure is exerted on the reservoir bottles and may cause cracks in the bottles. It could break the reservoir bottles and cause injury.

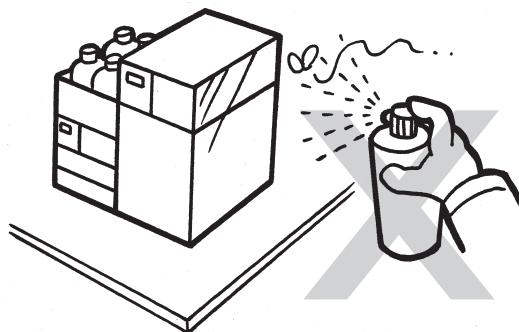

- **Do not use flammable sprays (hair sprays, insecticide sprays, etc.) near the instrument.**

They could ignite and cause a fire.

- **Be careful not to apply water to office equipment such as the PC as well as the instrument.**

- **Install the low-pressure Hg (Mercury) lamp before turning on the power of the lamp.**

Looking straight at the lamplight could damage eyes.

■ Precautions for Instrument Inspection, Maintenance, Adjustment and Care**⚠ WARNING**

- **Unplug the instrument before inspection, maintenance, or parts replacement.**

Otherwise, electrical shock or short-circuit accidents could occur.

- **Never remove the main cover.**

This may cause injury or malfunction of the instrument.

The main cover does not need to be removed for routine maintenance, inspection and adjustment. Have your Shimadzu representative perform any repairs requiring removal of the main cover.

- **Replace fuses only with fuses of the proper type and capacity.**

Any other fuses could cause a fire.

- **If the power cord plug gets dusty, remove the plug from the power outlet and wipe away the dust with a dry cloth.**

If dust is allowed to accumulate, fire could result.

- **Replacement parts must be of the specifications given in "1.2 Component Parts" or "1.3 Maintenance Parts".**

Use of any other parts may result in instrument damage and malfunction.

- **If any water gets onto the instrument, wipe it away immediately to prevent rust. Never use alcohol or thinner solvents for cleaning the instrument.**

They could cause discoloration.

- **Dispose of the waste liquid properly and in accordance with the instruction by your administrative department.**

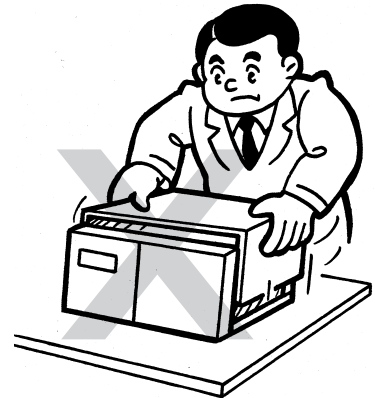

■ In Case of Emergency

 **WARNING**

If any problem is detected, such as a burning smell, take the following action:

Procedure

- 1** Turn the power to the instrument OFF.
- 2** Disconnect the power cable at the rear of the instrument.

When the instrument is used again, inspect the instrument and, if necessary, contact your Shimadzu representative to request servicing.

■ In Case of Power Outage

 **CAUTION**

Take the following measures in the event of a power outage.

Procedure

- 1** Turn the power to the instrument OFF.
- 2** After confirming all related items in this section "Installation Precautions" and "Operation Precautions", use the standard startup procedure to start the instrument.

Maintenance, Inspections, and Adjustment

In order to maintain the instrument's performance and obtain accurate measurement data, daily inspection and periodic inspection/calibration are necessary.

- For daily maintenance, inspection, and replacement parts, see the "[5 Maintenance](#)" section of this Instruction Manual.
- Periodic inspection/calibration should be requested to your Shimadzu representative.
- Replacement cycles described for periodic replacement parts are rough estimate. Replacement may be required earlier than the described replacement cycles depending on usage environment and frequency.

Disposal Precautions

■ California Regulations Concerning Perchlorate



CAUTION

For California, USA Only

This product contains a battery that contains perchlorate material.

Perchlorate Material - special handling may apply.

See www.dtsc.ca.gov/hazardouswaste/perchlorate

This page is intentionally left blank.

Contents

Instruction Manuals.....	I
■ CBM-20A Instruction Manual (brief manual)	I
■ CBM-20A Instruction Manual (detailed manual) [PDF Instruction Manual]	I
■ Installing Internet Explorer	I
■ Content of the CD-ROM	II
■ Model Names	II
Introduction	III
Warranty and After-Sales Service.....	IV
Safety Instructions	VI
■ Application Precautions	VI
■ Installation Site Precautions	VII
■ Installation Precautions	VIII
■ Operation Precautions	X
■ Precautions for Instrument Inspection, Maintenance, Adjustment and Care	XI
■ In Case of Emergency	XII
■ In Case of Power Outage	XII
Maintenance, Inspections, and Adjustment	XIII

Chapter 1 Configuration

1.1	Overview.....	1-1
	1.1.1 Features.....	1-1
	1.1.2 Equipment Required for Connecting to the Network.....	1-2
1.2	Component Parts.....	1-4
1.3	Maintenance Parts.....	1-5
1.4	Specifications.....	1-5
	1.4.1 CBM-20A	1-5
	1.4.2 Specifications for External Connections	1-6
	1.4.3 Control Specifications	1-8

Chapter 2 Parts Identification and Function

2.1	Front Cover.....	2-1
2.2	Back.....	2-2
2.3	Applications and Windows.....	2-4
	2.3.1 "Group Monitor" Application.....	2-6
	2.3.2 "Analysis Execution" Application.....	2-7

2.4	"Login" Window	2-8
2.5	"Error" Window	2-9
2.6	Precautions Related to Internet Explorer Operations	2-10

Chapter 3 Preparation

3.1	Managing Several Systems as One Group	3-1
3.1.1	User Level and Access Level	3-2
3.1.2	Setting IP Addresses	3-3
3.1.3	Setting Group and System Names	3-5
3.1.4	Registering New Users	3-6
3.1.5	Group Information, System Administration, and User Management	3-6
3.2	Starting the CBM-20A	3-8
3.3	Determine the System Configuration	3-9
3.3.1	Checking Connections between the System Controller and Components	3-10
3.3.2	Selecting the Pumping Mode	3-10
3.3.3	Selecting the Unit-name Allocation Method	3-12

Chapter 4 Basic Operation

4.1	Overall Flow of Operation	4-1
4.2	Starting the System Components	4-2
4.3	Starting Internet Explorer and Connecting to the CBM-20A	4-2
4.4	Logging In and Displaying the "Analysis" Tab Page	4-2
4.5	Creating Method Files	4-3
4.5.1	Selecting Method Files	4-3
4.5.2	Editing the "Method Parameter" Window	4-4
4.5.3	Parameters for the Solvent Delivery Module	4-5
4.5.4	Parameters for the CBM-20A	4-6
4.6	Gradient Analysis Using Time Programs	4-7
4.6.1	Displaying the "Time Program" Window	4-8
4.6.2	Creating Time-program Tables	4-9
4.6.3	Time-program Setting Example	4-10

4.7	Creating Sequence Files	4-11
4.7.1	Selecting Sequence Files	4-11
4.7.2	Creating Sequence Tables	4-12
4.8	Preparing Samples	4-14
4.9	Executing Autopurge	4-14
4.10	Waiting for the System to Stabilize	4-17
4.11	Executing Analysis.....	4-17
4.12	Turning OFF the Solvent Delivery Module and Column Oven.....	4-18
4.13	Quitting Analysis.....	4-18
4.14	Quitting the System	4-18

Chapter 5 Maintenance

5.1	Checking the System.....	5-1
5.1.1	System Check Results	5-3
5.1.2	Saving the Results of System Checks	5-5
5.2	Checking Maintenance Information	5-6
5.2.1	Displaying the "Maintenance" Tab Page.....	5-6
5.2.2	"Maintenance" Tab Page Display.....	5-6
5.3	Periodic Inspection and Maintenance.....	5-7
5.3.1	Periodic Inspection and Maintenance	5-7
5.3.2	Exterior Cleaning	5-7
5.4	Error Message	5-8
5.4.1	Errors at Power ON.....	5-8
5.4.2	Operating Errors	5-8

This page is intentionally left blank.

1 Configuration

1.1 Overview

1.1.1 Features

- This system controller is equipped with networking capability as a standard feature. By using the Web-server function, it is possible to set analysis conditions, execute analysis, and monitor the system from a PC. It is also possible to process the data at the Chromatopac by linking the system controller to a Chromatopac.
- Connecting to a Shimadzu data-processing workstation allows the user to set analysis conditions, execute analysis, monitor the system and process the data all from a remote PC.
- The special optical-link interface enables the connection and control of the LC-30A/20A/10Avp/10A-series Solvent Delivery Module (Pump), Autosampler, Column Oven, Detector, and Fraction Collector. It is also possible to connect and control the SPD-M20A/M30A Photodiode Array Detector as a 4-wavelength detector or the SPD-30AM Multi Wavelength Detector from the system controller via the network.

System Configuration Example

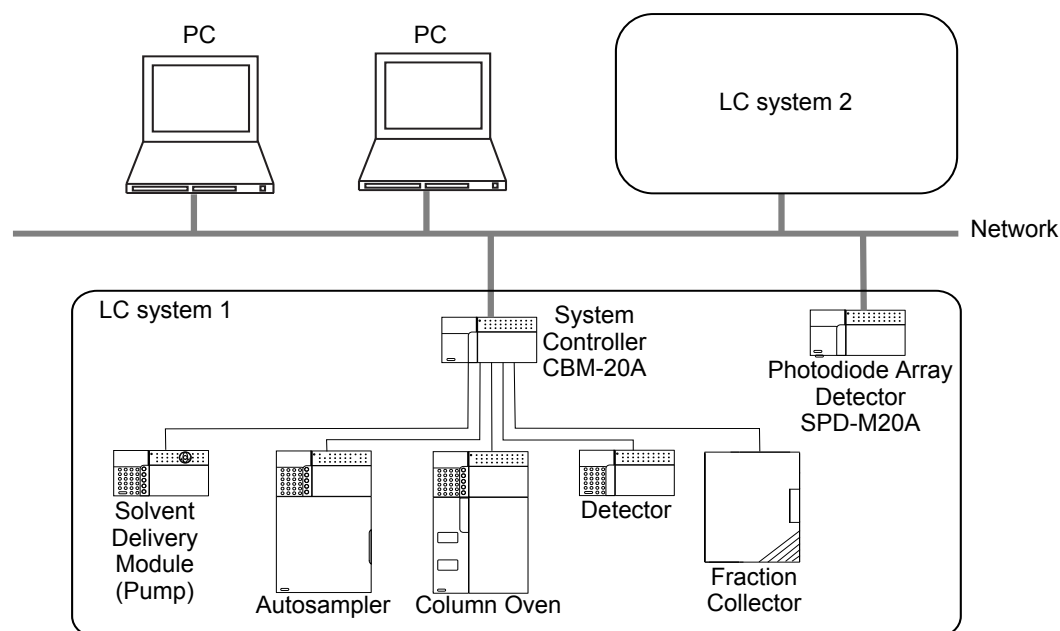

Fig. 1.1

1. Configuration

1.1.2 Equipment Required for Connecting to the Network

This system controller is network ready. This makes it possible to set HPLC system parameters and to create and execute analysis schedules from a Web browser. The system controller can also be connected to a Shimadzu workstation using the TCP/IP protocol. The hardware requirements for using the Web browser and connecting to the network are described below.

■ PC

Name	Remark
PC	CPU : Intel Celeron 800 MHz or higher Memory : 256 MB min. LAN adapter : 100Base-TX compatible Display : 1024 × 768 or higher OS : Windows2000/XP/Vista/7 Other : Internet Explorer 6.0 SP1 or later /7/8/9

- The CPU specification is only a recommendation.
- The memory and LAN specifications are necessary requirements.
- The OS must be one for which correct operation has been confirmed. Correct operation cannot be assured with Windows 95, 98, Me, or NT.

■ Network Cables and Devices

Network Configuration Example

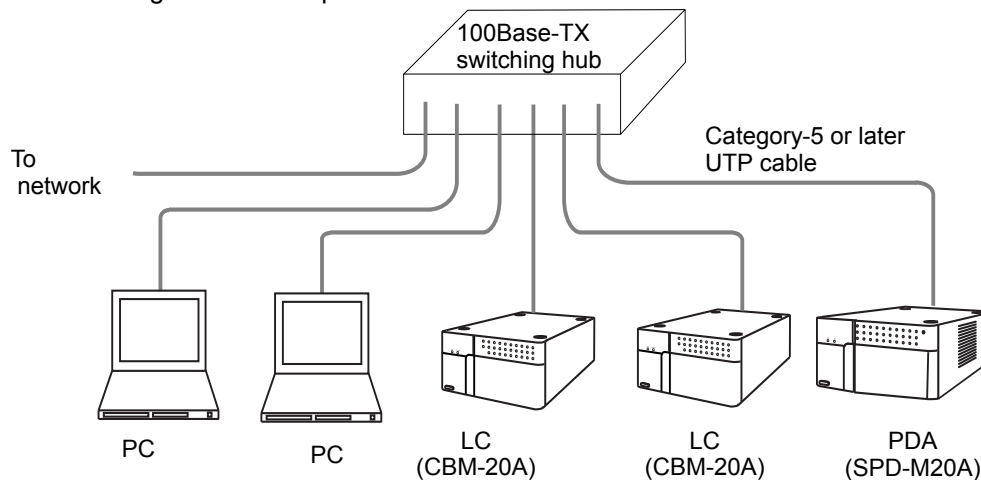

Fig. 1.2

Name	Remark
Straight LAN cable	Category-5 or later UTP straight cable
Switching hub	100Base-TX compatible
Cable holder	Required when routing the LAN cable along the floor or across a wall.

- Use commercial products satisfying the specifications given in the "Remark" column.
- One LAN cable is required for every PC, CBM-20A/20Alite, and SPD-M20A/M30A/30AM.
- If the total number of PCs, CBM-20A/20Alite System Controllers, SPD-M20A/M30A Photodiode Array Detectors, and SPD-30AM Multi Wavelength Detectors is greater than the number of ports on the switching hub, increase the number of ports as appropriate using cascade connections.
- Before connecting to the network, consult the network administrator of the department or office where the system will be used.

1.2 Component Parts

This instrument consists of the standard parts listed below. Check the parts against this list after unpacking.

The standard parts provided depend on the power supply voltage. (See below.) After unpacking, verify that the correct types and quantity of parts have been provided.

For S228-45012, the 2-digit numbers in the remark column in the table below indicate the power supply voltages for the part. -31, -41 indicates use with a 100 V power supply, -32, -42 is a 120 V power supply, and -38, -48, -58 a 220-240 V power supply.

These 2-digit figures refer to the last two digits in the product number of the instrument. -31, -41 is for products destined for Japan, while -32, -42 and -38, -48, -58 are for use in other countries.

■ CBM-20A(S228-45012)

Part	Part No.	Q'ty	Remark
CBM-20A	-		
Instruction manual	S228-30846	1	-31, -41 only
Instruction manual	S228-30847	1	-32, -38, -42, -48, -58 only
Bus cable	S228-41977	1	
Power cable	S071-60821-08	1	-31, -32, -41, -42 only
Power cable	S071-60825-51	1	-38, -48, -58 only
AC Power cable (for China)	S465-06046	1	-46 only
LAN cable	S228-61083-91	1	Straight cable -31, -32, -38 only
	S228-61083-41	1	Straight cable -41, -42, -48, -58 only
CD-ROM	S228-42654-91	1	

■ CBM-20Alite(S228-45011)

Part	Part No.	Q'ty	Remark
CBM-20Alite	-		
Instruction manual	S228-30846	1	-31, -41 only
Instruction manual	S228-30847	1	-38, -48, -58 only
Control cable	S228-41797-91	1	
LAN cable	S228-61083-91	1	Straight cable -31, -32, -38 only
	S228-61083-41	1	Straight cable -41, -42, -48, -58 only
CD-ROM	S228-42654-91	1	

1.3 Maintenance Parts

Part	Part No.	Remark
Fuse, 250 V 4 AT	S072-02004-22	CBM-20A only

1.4 Specifications

1.4.1 CBM-20A

Item	Specification	
	CBM-20A	CBM-20Alite
Power Supply ¹	100 to 120 or 220 to 240 VAC, 50/60 Hz, 400 VA ³	5 VDC 1 A Supplied from the incorporated instrument
Rated Breaking Capacity ²	40A	
Installation Environment (IEC)	Installation Category II Pollution Degree 2 Altitude 2000 m or lower Install inside the room.	
Operating Temperature Range	4 °C to 35 °C	
Dimensions	W 260 × H 140 × D 420 mm, excluding protruding parts	W 144 x H 45 x D 130 mm, excluding protruding parts
Weight	5.5 kg	0.4 kg

- 1: Mains supply voltage fluctuations are not to exceed 10 % of the nominal supply voltage.
- 2: Connect the instrument to a power outlet that is equipped with a circuit breaker that shuts off the current at the described value or less.
- 3: If the AC output connectors are not used, this value is 100 VA.

1. Configuration

1.4.2 Specifications for External Connections

■ Input/Output Connectors

Connector	Number of connectors		Remark
	CBM-20A	CBM-20Alite	
External start input (MAN.INJ.)	1	1	Relay contact input
Error input (IN)	3	1	Relay contact input
General-purpose output (OUT) (See note 1.)	4	2	Relay contact input
Remote connector (REMOTE)	8 Up to 12 (See note 2.)	4	Used for controlling LC components.
Ethernet (ETHERNET)	1	1	Used for network connection.
Optical link (PAC)	1 (See note 3.)	1	Used for connecting to Chromatopac. (Also functions as a remote connector.)
RS-232C	1	1	Used for connecting to a PC.
External power-receptacle output (AC REMOTE)	1	-	Used for connecting to multiple terminal box.
AC output (operationally linked to power switch)	2	-	Used for the autosampler, fraction collector, or sub-controller.

1. Used for start, stop, or error output. Can also be set from a program.
2. The optional CBM-20A OPT4 is required.
3. When a Chromatopac is connected to the optical link (PAC) connector, an RS-232C connector cannot be used.

■ Connectable HPLC Components

The components and options that can be controlled from the system controller are given in the following table.

● Connectable HPLC Components

	LC-30A Series	LC-20A Series	LC-10Avp Series	LC-10A Series etc. (See note 1.)	Maximum number of connectable units	
					CBM-20A	CBM-20Alite
Solvent Delivery Module	LC-30AD LC-30ADSF (See note 8.)	LC-20AB LC-20AD LC-20ADXR LC-20AT LC-20AP LC-20AR LC-20Ai	LC-10ADvp LC-10ATvp	LC-10AD LC-10AT LC-10Ai LC-10AS LC-8A (See note 2.) LC-6AD (See note 2.) LC-7A (See note 2.)	4	4
Autosampler	SIL-30AC SIL-30ACMP SIL-30ACFV (See note 8.) SFE-30A (See note 8.)	SIL-20A SIL-20AC SIL-20AXR SIL-20ACXR	SIL-10ADvp	SIL-10A SIL-10AF SIL-10AP SIL-10Ai SIL-10AXL	1 (See note 3.)	1 (See note 4.)
Column Oven	CTO-30A CTO-30AS	CTO-20A CTO-20AC	CTO-10Avp CTO-10ACvp CTO-10ASvp	CTO-10A CTO-10AC	4 (See note 7.)	4 (See note 7.)
Detector		SPD-20A SPD-20AV RF-20A RF-20Axs RID-20A	SPD-10Avp SPD-10AVvp CDD-10Avp (See note 5.) CDD-10Asp (See note 5.)	SPD-10A SPD-10AV SPD-10Ai SPD-10AVi RF-10AXL RF-10A RID-10A	2	2
Fraction Collector				FRC-10A	1	-
Sub-controller			Sub-controller vp Option Box vp	Option Box L Valve Interface	2 (See note 3.)	-
Photodiode Array Detector/ Multi Wavelength Detector	SPD-M30A (See note 6.) SPD-30AM	SPD-M20A (See note 6.)			1	1
Supercritical Controller	SFC-30A (See note 8.)				2	2

1. Connection is supported to version 3, or higher, LC-10A-series components.
2. The optional PC-31L is required for the LC-8A/6AD/7A. The version number for these components is not displayed in the "Configuration" tab page.

1. Configuration

3. When connecting to one SIL-10A/10AF/10AP/10Ai/10AXL and two Sub-controllers (total 3 units), the optional multiple terminal box (Part No.S228-31625-91 for 100 V area or -92 for 200 V area) and a power cable (Part No.S071-60821-08 for 100 V area or S071-60825-51 for 200 V area) are required.
4. LC-10A-series Autosamplers cannot be connected.
5. CDD-10Avp/sp can be connected in combination of CBM-20A/20Alite version 1.20 (or later) and LCsolution version 1.24 (or later) or LabSolutions version 5.2 (or later). When using the CDD-10Avp/sp system, be sure to perform operations on the LCsolution or LabSolutions software. When using Chromatopac on the CDD-10Avp/sp system, be sure to use the SCL-10Avp system controller. Note that operations of CBM-20A/20Alite on the Web application window using Internet Explorer are not guaranteed.
6. The Photodiode Array Detector can be controlled as a 4-wavelength detector from the system controller via the network.
7. When CBM-20A/20Alite version 2.40 (or later) and LabSolutions version 5.54 (or later) are connected in combination, a maximum of four column ovens can be controlled. In addition, two column ovens can be controlled by operating the CBM-20A/20Alite on the Web application window using Internet Explorer.
8. Note that operations of CBM-20A/20Alite on the Web application window using Internet Explorer are not guaranteed.

1.4.3 Control Specifications

Item		Control	
		Internet Explorer	LC workstation
Analysis files (parameters, time programs)	Number of files	20	Depends on PC.
	Number of time-program steps	400 (total for all files)	400
	Program time	0.01 to 9999.9 minutes	0.01 to 9999.9 minutes
Analysis-sequence files	Number of files	12	Depends on PC.
	Number of steps	100 (per file)	
Autosampler-pretreatment files		Creation not supported.	Depends on PC.
Scan data		Display not supported.	Display supported.
Control of solvent delivery module	Pumping mode	<ul style="list-style-type: none"> • Isocratic • High-pressure gradient • Low-pressure gradient 	<ul style="list-style-type: none"> • Isocratic • High-pressure gradient • Low-pressure gradient • Constant-pressure pumping
	Setting items	<ul style="list-style-type: none"> • Flow rate • Concentration • Maximum pressure • Minimum pressure 	<ul style="list-style-type: none"> • Flow rate • Pressure • Concentration • Maximum pressure • Minimum pressure
	Gradient profile	<ul style="list-style-type: none"> • Straight line • Step • Exponential 	<ul style="list-style-type: none"> • Straight line • Step • Exponential

Item		Control	
		Internet Explorer	LC workstation
Control of autosampler	Setting items	<ul style="list-style-type: none"> • Sample injection volume • Number of repeated analyses • Analysis time analysis-file number 	<ul style="list-style-type: none"> • Sample injection volume • Number of repeated analyses • Analysis method
Control of column oven	Setting items	<ul style="list-style-type: none"> • Oven temperature • Maximum temperature 	<ul style="list-style-type: none"> • Oven temperature • Maximum temperature
Control of detector	Setting items	<ul style="list-style-type: none"> • Detector wavelength • Time constant • Lamp replacement etc. 	<ul style="list-style-type: none"> • Detector wavelength • Recorder range • Polarity • Time constant • Scan etc.
Control of fraction collector	Setting items	<ul style="list-style-type: none"> • Fractionation conditions • Peak-detection conditions • Analysis conditions etc. 	<ul style="list-style-type: none"> • Fractionation conditions • Peak-detection conditions • Analysis conditions etc.



In the case of the Nexera UC series instruments (LC-30ADSF, SFE-30A, and SFC-30A), operations using Internet Explorer are not guaranteed.

The following component functions cannot be used when controlling the system controller from Internet Explorer.

Component	Restricted item
Solvent Delivery Module	<ul style="list-style-type: none"> • Control based on constant pressure • Compressibility setting (See note 1.)
Autosampler	<ul style="list-style-type: none"> • Creation of pretreatment files (Operation is based on standard injection conditions.) • Stat analysis • Reagent vials for SIL-10ADvp and Reagent rack for SIL-10A series
Detector	<ul style="list-style-type: none"> • Executing and displaying data for spectral scans <p>UV/UV-VIS detector (SPD):</p> <ul style="list-style-type: none"> • REC MODE setting and output of ratio-chromatogram signal (See note 2.) • RANGE setting and output of recorder signal (See note 3.) • POLARITY setting (See note 4.) <p>Fluorometric detector (RF-20A/20Axs)</p> <ul style="list-style-type: none"> • ANALOG 1 MODE and ALALOG 2 MODE settings and output of recorder signal (see note 5.) • 3-wavelength mode and 4-wavelength mode settings and data display

1. Configuration

Component	Restricted item
Fraction collector	<ul style="list-style-type: none"> Setting of fractionation parameters using chromatogram display window

- If the solvent delivery pump (LC-30AD, LC-20AP, LC-20AR and LC-20Ai) parameters are changed with Internet Explorer, the compressibility setting is automatically made to the value set at the instrument.
- If UV/UV-VIS-detector (SPD) parameters are changed with Internet Explorer, the REC MODE setting is automatically changed to 1 (i.e., when performing measurement with 2 channels, the absorbance for channel 2 is output to the recorder terminals). For this reason, the ratio-chromatogram signal cannot be output to the recorder terminals.
- The REC RANGE setting is changed automatically in accordance with the AUX RANGE setting.
- The POLARITY setting is automatically changed to "+".
- If fluorometric detector (RF-20A/20Axs) parameters are changed with Internet Explorer, the ANALOG 1 MODE and ANALOG 2 MODE settings are automatically changed as follows.
 - When the wavelength mode is set to [Single]
 - ANALOG 1 MODE: 0 (Ch1 data is output to the Chromatopac from the analog output connector 1.)
 - ANALOG 2 MODE: 1 (Ch1 data is output to the recorder from the analog output connector 2.)
 - When the wavelength mode is set to [Dual]
 - ANALOG 1 MODE: 0 (Ch1 data is output to the Chromatopac from the analog output connector 1.)
 - ANALOG 2 MODE: 2 (Ch2 data is output to the Chromatopac from the analog output connector 2.)
 The RANGE (recorder range 2) setting cannot be specified. (It can be specified only when the wavelength mode is [Single].)

■ Other Specifications

Item	Function
Data backup	Analysis methods, analysis sequences and other parameters are backed up even when power is interrupted. The clock-counter function has battery backup.
Self-diagnosis	There is a memory-check function that operates at startup.
Safety measures	Connecting to other units with an optical cable makes it possible to perform error monitoring for the following items: <ul style="list-style-type: none"> Maximum/minimum pressure Maximum oven temperature Lamp current Error monitoring for motor rotation System maximum pressure (See note 1.)

- By using the system P.MAX setting, the maximum pressure at the autosampler can be monitored.
 For details about the system P.MAX, refer to "5.12.6 System Controller" in the CBM-20A Instruction Manual (detailed manual).

2 Parts Identification and Function

2.1 Front Cover

■ CBM-20A

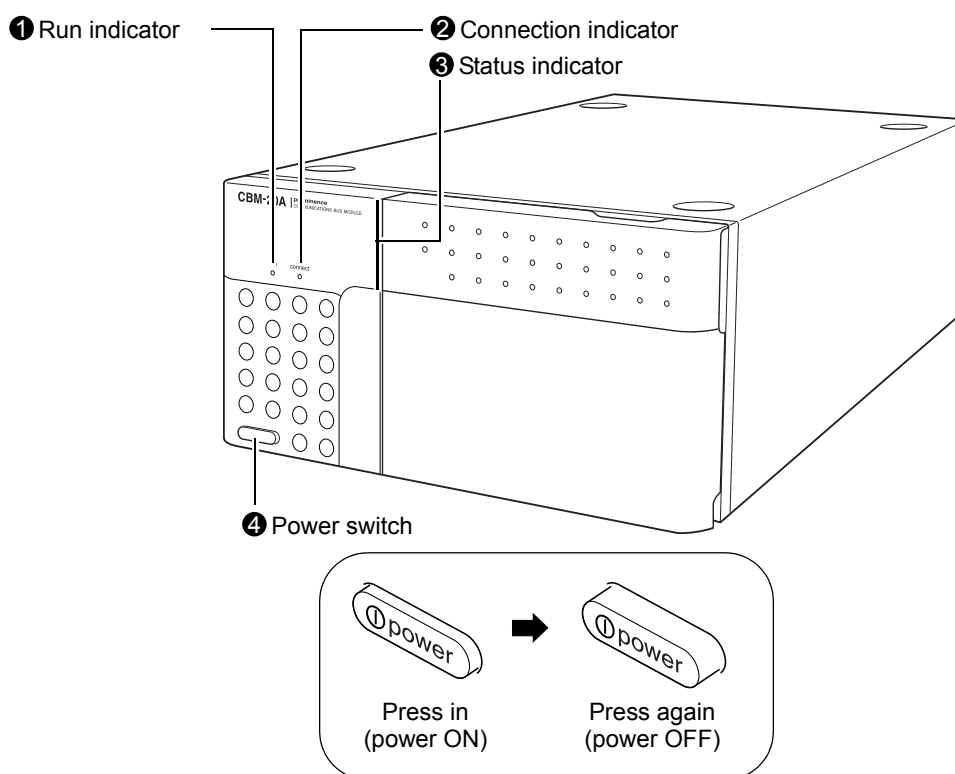

Fig. 2.1

	Name	Description
①	Run indicator	Turns ON when analysis starts and turns OFF when analysis stops.
②	Connection indicator	Turns ON when the system controller is controlled from PC (Internet Explorer, LC workstation) or Chromatopac. Flashes during execution of the "Group Settings" or "System Check" application.
③	Status indicator	Indicates the system status using different colors. Green: Power ON Red: Error Orange: Shut down status or sleep status
④	Power switch	Used to turn power ON/OFF. Press the switch in to turn power ON. Press again to turn power OFF.

2.2 Back

■ CBM-20A

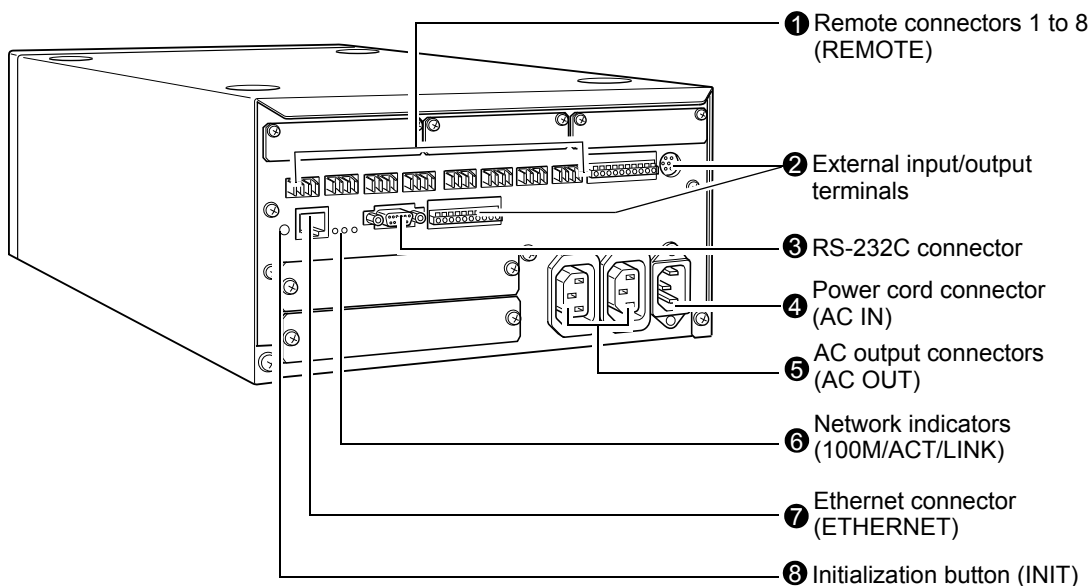

Fig. 2.2

	Name	Description
①	Remote connectors 1 to 8 (REMOTE)	Connectors for connecting to LC-30A/LC-20A/LC-10Avp/ LC-10A-series components.
②	External input/output terminals	Terminals for exchanging input/output signals with external devices, such as manual injectors.
③	RS-232C connector	Connector for exchanging data with a PC or Chromatopac. Mainly used to connect to a PC.
④	Power cord connector (AC IN)	Connector for connecting the power cable.
⑤	AC output connectors (AC OUT)	These connectors are for AC power output and are operationally linked to the power switch. They can be used to supply power to Shimadzu HPLCs (SIL-10A Series, FRC-10A, Sub-controllers). Do not use them for any other application.
⑥	Network indicators (100M/ACT/LINK)	Display the status of connection to the network using LED indicators. 100M: Turns ON when operating at 100 Mbps. ACT : Turns ON when exchanging data. LINK : Turns ON when linked to the network.
⑦	Ethernet connector (ETHERNET)	Connector for connecting to the network.
⑧	Initialization button (INIT)	Push to initialize the system controller or clear errors.

■ CBM-20Alite

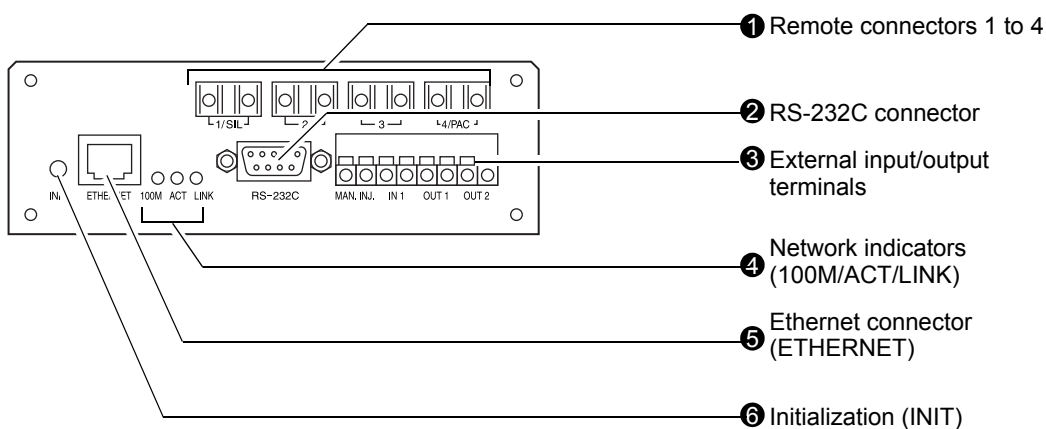

Fig. 2.3

	Name	Description
①	Remote connectors 1 to 4 (REMOTE)	Connectors for connecting to LC-30A/20A/10Avp/10A-series components.
②	RS-232C connector	Connector for exchanging data with a PC or Chromatopac. Mainly used to connect to a PC.
③	External input/output terminals	Terminals for exchanging input/output signals with external devices, such as manual injectors.
④	Network indicators (100M/ACT/LINK)	Display the status of connection to the network using LED indicators. 100M: Turns ON when operating at 100 Mbps. ACT : Turns ON when exchanging data. LINK : Turns ON when linked to the network.
⑤	Ethernet connector (ETHERNET)	Connector for connecting to the network.
⑥	Initialization button (INIT)	Push to initialize the system controller or clear errors.

2.3 Applications and Windows

The components in an LC system can be controlled from Internet Explorer running on a PC by accessing the system controller's Web server.

There are four basic applications (programs) that can be executed from the system controller's Web server: the "Group Monitor" application, the "Analysis Execution" application, the "System Check" application, and the "Group Settings" application.

Each application consists of a main window divided into sections with tab pages and sub-windows that are opened from inside the application.

The windows for the "Group Monitor" and "Analysis Execution" applications as well as the "Login" and "Error" windows that are displayed when operating the system controller are described in the following section.

"Group Monitor" application  P.2-6

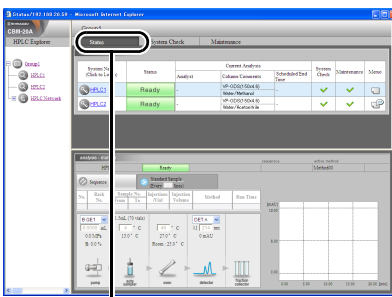

"Group Monitor" application  P.2-6

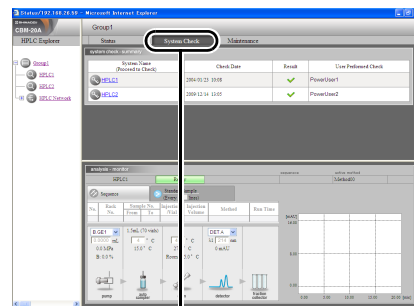

"Login" window  P.2-8

"Login" window  P.2-8

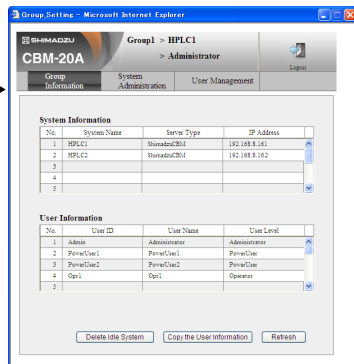

"Group Settings" application  P.3-1

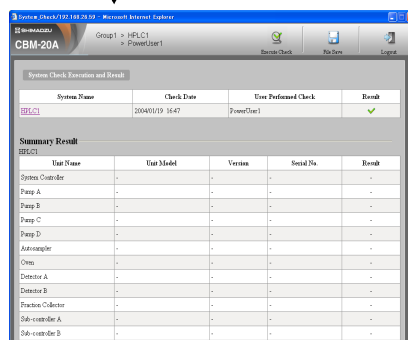

"System Check" application  P.5-1

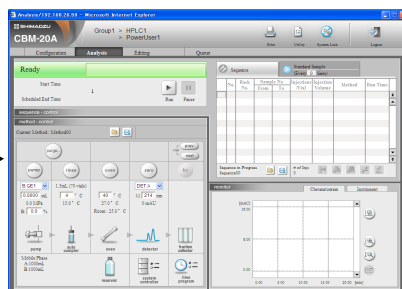

"Analysis Execution" application  P.2-7

■ List of Windows

List of Screens

The list of screens in the application of this instrument is shown on the following table. For details of each screen refer to the Instruction Manual (detailed manual).

Application	Main sub-windows
Window for tab page (including windows that are divided into frames)	
"Group Monitor" application	"Login" window
"HPLC Explorer" section	
"Status Summary" section	
"Status" tab page	
"System Check" tab page	
"Maintenance" tab page	
"System Monitor" section	
"Analysis Execution" application	"Print", "Utility" and "Error" windows
"Configuration" tab page	
"Analysis" tab page	"Autopurge" window, "Mobile Phase Reserve Volume Setting" window, "Method Parameter" window, "Time Program" window, "Gradient Curve" window, "Load File" window, "Save File" window, "Chromatogram Setting" window
"Editing" tab page	"Method Parameter" window, "Time Program" window, "Gradient Curve" window, "Load File" window, "Save File" window
"Queue" tab page	"Advanced Shutdown Settings" window, "Startup Advanced Settings" Window
"System Check" application	"Error" window
"Group settings" application	
"Group Information" tab page	
"System Administration" tab page	"Advanced Settings" window
"User Management" tab page	

2. Parts Identification and Function

2.3.1 "Group Monitor" Application

This is the first application that is started when the Web server is accessed. The Group Monitor application window consists of three sections: "HPLC Explorer", "Status Summary", and "System Monitor".

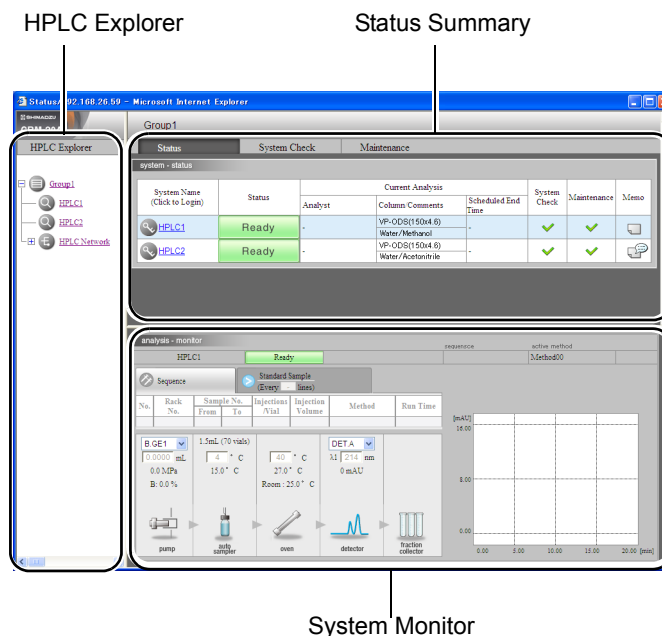

■ "HPLC Explorer" Section

The systems in the group (up to a maximum of 10) and other systems are displayed in tree format.

■ "Status Summary" Section

The "Status Summary" section consists of the following three tab pages.

- "Status" tab page
- "System Check" tab page
- "Maintenance" tab page

All pages are accessible by clicking the tabs. The "Status" tab page remains visible when accessing via the Web server.

■ "System Monitor" Section

The "System Monitor" section displays monitoring information for the system currently being accessed.

2.3.2 "Analysis Execution" Application

The "Analysis Execution" application window is displayed after login. The "Configuration", "Analysis", "Editing", and "Queue" tab pages are contained in this application. Click the tabs to change tab pages. The "Analysis" tab page is always displayed while the user is logged in.

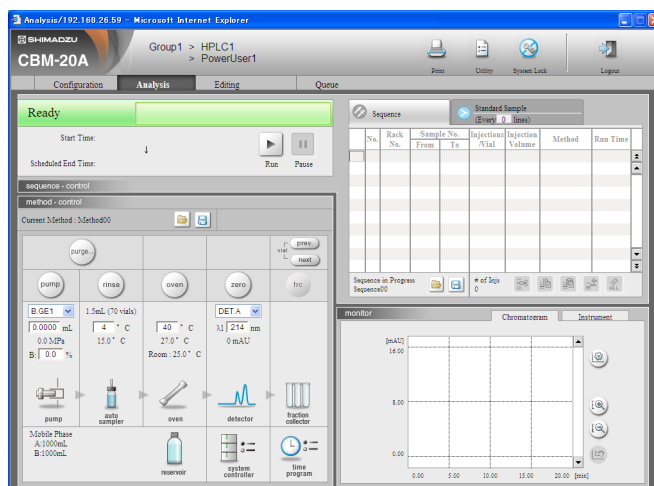

■ "Analysis" Tab Page

This page is used to start the analysis sequence, edit the selected method or sequence files, control the system components, and display chromatograms. The "Analysis" tab page consists of three sections: "Sequence", "Method", and "Monitor".

- "Sequence" Section
This section is used to edit the sequence file and start the analysis sequence.
- "Method" Section
The selected method file can be edited and the systems can be controlled directly from the "Method" section.
- "Monitor" Section
The "Monitor" section displays the chromatogram of the selected detector in the pull-down menu for "Method" section as well as monitor values for the other system components.

■ "Configuration" Tab Page

The system configuration can be set and checked from the "Configuration" tab page.

■ "Editing" Tab Page

Method files can be edited and sequence files can be assigned to the analysis queue from the "Editing" tab page.

■ "Queue" Tab Page

The analysis sequences assigned to the analysis queue can be reviewed and the startup/shutdown settings can be set in the "Queue" tab page.

2.4 "Login" Window

The "Login" window is displayed when the system name on the "Status" tab page ["■"Status Summary" Section" P. 2-6](#) is clicked. It is possible to log into the "Analysis Execution" application and the "Group Settings" application from this window. To log in, enter a previously registered user ID and password.

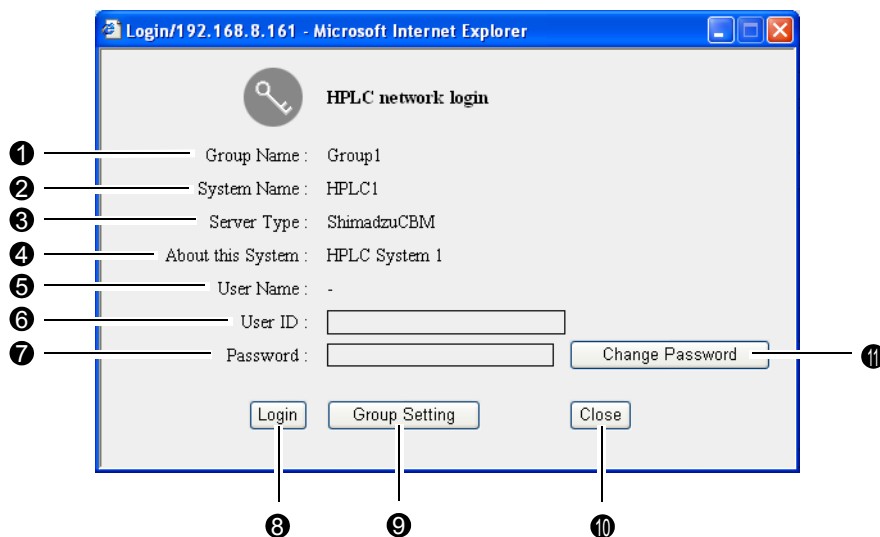



	Display item	Description
①	Group Name	Displays the name of the group to which the system belongs.
②	System Name	Displays the name of the system configured by the solvent delivery module, autosampler, column oven, detector, and other components. The system name is set by the administrator.
③	Server Type	Displays the Web server type ([ShimadzuCBM] in this case).
④	About this System	Displays an explanation about the system. The explanation is set by the administrator.
⑤	User Name	Display the name of user if there is already a user logged in.
⑥	User ID	Enter a user ID. (The initial setting for the user ID is "Admin".)
⑦	Password	Enter a password. (The initial setting for the password is "Admin".)
⑧	<input type="button" value="Login"/>	Click to login to the "Analysis Execution" application.
⑨	<input type="button" value="Group Setting"/>	Click to login to the system controller's "Group Settings" application. "3.1 Managing Several Systems as One Group" P. 3-1
⑩	<input type="button" value="Close"/>	Click to close the "Login" window without logging in.
⑪	<input type="button" value="Change Password"/>	Click to change the password.

2.5 "Error" Window

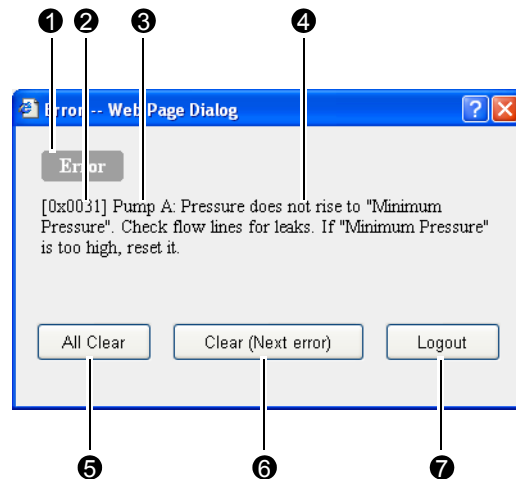
The "Error" window is displayed when an error occurs.



	Display item	Description
①	Classification	Depending on the type of error, "Warning", "Error" or "Fatal Error" may be displayed.  "5.4 Error Message" P. 5-8
②	Error code	Displays a 6-digit alphanumeric error code.
③	Unit name	Displays the name of the component for which the error occurred.
④	Error message	Displays an explanation of the error.
⑤	All-clear button	Click to clear all errors except fatal errors.
⑥	Clear button	Click to clear the currently displayed (non-fatal) error. The window closes when all errors are cleared.
⑦	Logout button	If a fatal error occurs, in accordance with the message, click the button, close all windows, and reset the power to the system controller.

 It is also possible to clear all errors except fatal errors by pushing the initialization button on the back of the system controller.

2.6 Precautions Related to Internet Explorer Operations

Note the points described below when making settings and performing other operations for the system controller using Internet Explorer.

■ Popup Blocker

When pop-up blocker software such as a security software or a toolbar for a browser is installed in the PC, Internet Explorer may not open the CBM-20A's Web application window. Please invalidate the pop-up block function for the URLs of the CBM or change the setting of the PC to disable the pop-up block function. After invalidating the pop-up block function, delete temporary files by selecting [Tools] - [Internet Options] - [Delete Files] in Internet Explorer.

■ Internet Explorer Settings

In order to use Internet Explorer, select [Tools] and [Internet Options] and configure the following settings. Internet Explorer 6 (IE6) to Internet Explorer 9 (IE9) can be used; note that some setting items and methods are different.

I [General]

Click the [Settings] button for "Temporary Internet Files" (for IE7, IE8, or IE9, [Settings] button for "Browsing history") and set the "Amount of disk space to use" (for IE7, IE8, or IE9, "Disk space to use") to 100 MB. (*1)

II [Security]

(1) Select [Local intranet] and click the [Sites] button. Set the Local Internet zone to include the system controller URLs. Specifically, add the system controller's URL in the [Advanced] screen.

Example: `http://192.168.*.*` or `http://192.168.200.99`

(To use the system name for access in IE7, IE8, or IE9, add `http://"system name".`)

(2) Click the [Customize Level] button and configure the following settings.

- Select "Enable" under "Run ActiveX controls and plug-ins" in "ActiveX controls and plug-ins".
- Select "Enable" under "Script ActiveX controls marked safe for scripting" in "ActiveX controls and plug-ins".
- Select "Enable" under "Active scripting" in "Scripting".
- Select "Enable" or "Prompt" under "Access data sources across domains" in "Miscellaneous". (*2)
- Select "Enable" under "File download" in "Downloads". (*3)

III [Connections]

Click the [LAN Settings] button and view the "Use a proxy server for your LAN" check box.

If it is checked, configure the following settings. (*4)

- Check the "Bypass proxy server for local addresses" check box.
- Click [Advanced] button and add the system controller's URL in "Exceptions".
Example: `192.168.*.*` or `192.168.200.99`

IV [Advanced]

- Check the "Display a notification about every script error" check box in "Browsing". (*5)
- Check the "Print background colors and images" check box in "Printing". (*6)

(*1) If the "Amount of disk space to use" is too large, the following problems may occur.

- 1) The update speed of the Web screen becomes slow when the temporary files folder is full.
- 2) When the temporary files folder is full and free disk space decreases, the PC operation becomes unstable.

(*2) Used for "Group Settings" application.

(*3) Set to download method and sequence files.

(*4) This setting is unnecessary if no proxy server is used.

(*5) When script error occurs in Web application, the screen update stops. This setting is necessary to recognize this error.

(*6) Used for printing parameters in "Print" windows.

■ Entering and Confirming Parameter Settings

During data entry using Internet Explorer, settings are confirmed either by using the [Tab] key or by moving the cursor to another location and clicking the mouse button. Settings are not confirmed with the [Enter] key. Although the [Tab] key can be used to move the cursor to the next field when entering data for some parameters, in some windows, such as the windows used for editing sequence tables, the [Tab] key will not move to the next field. In these instances the mouse must be used to move to a different location.

■ Out-of-range Data

If data that is out of the acceptable range is entered, the data returns to its original value and is highlighted. Input a value that is within the acceptable range.

■ Screen Printout

The screen contents such as maintenance information and system configuration can be printed from Internet Explorer by pressing [Ctrl] [P]. Enter the appropriate printer settings in the "Print" window. If the on-screen printout range is larger than the default paper size, change the paper size and scaling settings as necessary. Note that, even if the paper size or scaling settings are changed, it may still not be possible to print out all the displayed contents on one sheet of paper.

■ Continuous Operation

Leaving Internet Explorer open for extended periods with the system controller connected may cause PC operation to become unstable. To avoid this;

- Shut down Internet Explorer once every day or so when running the system controller continuously. To suppress the consumption of PC resources, the Web application screen of CBM shuts and opens again automatically at midnight (4 a.m - 5 a.m).
- Avoid leaving three or more Web application windows opened for extended periods. Usually, limit use to one "Group Monitor" application and one "Analysis Execution" application.

2. Parts Identification and Function

■ Message during Operation

When the network load grows with the CBM-20A Web application opened, the following message may appear.

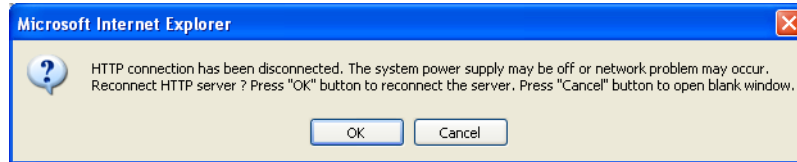

- (1) Click the button to continue using the application. The Web application stops when the button is clicked, and the screen is not updated.

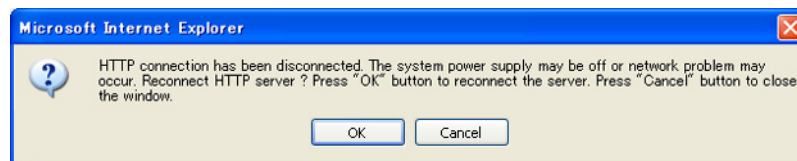

- (2) Click the button to continue using it. The Web application exits when the button is clicked.



The "Analysis Execution" application recognizes that the user is still logging in for five minutes after the communication is disconnected. After five minutes have passed, the application recognizes that the user has logged out. Therefore, if five minutes have passed since communication was terminated, the application logs out when is pressed. When pressing the button, relogin is not possible within five minutes after the communication was terminated.

■ Shortcut Keys

Dont press the shortcut keys such as the F5 (Refresh) key, the F11 (Full-screen) key. An error may occur or the screen layout may be disrupted.

3 Preparation

This chapter explains the settings that are required to allow several users to efficiently use several systems connected to the network.

3.1 Managing Several Systems as One Group

CBM-20A/20Alite controller monitor several system controllers via the network.

More specifically, the following operations are possible.

- The status of analysis execution for several systems can be monitored.
- System checks can be executed and the results can be viewed.
- Information on consumable parts in several systems can be displayed in list format and managed centrally.
- All the systems in one workplace or one group can be managed together.
- Management of system users is possible in group units.

Groups are created to use these functions. One group can contain a combined total of up to 10 CBM-20A/20Alite System Controllers, SPD-M20A/M30A PDA Detectors, and SPD-30AM Multi Wavelength Detectors.

Intranet Configuration Example

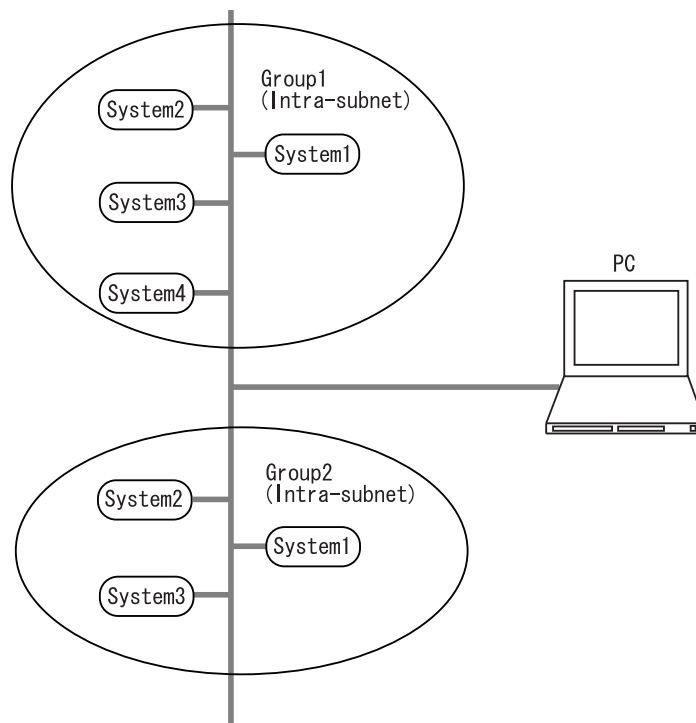
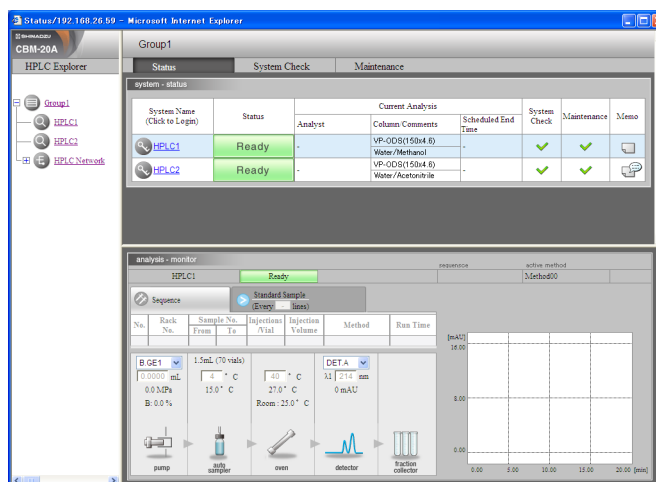

Fig. 3.1

3. Preparation



In order to configure group settings, all the CBM-20A/20Alite System Controllers, SPD-M20A/M30A PDA Detectors, and SPD-30AM Multi Wavelength Detectors must be in the same subnet, and the same group name must be set in the "Group Settings" application window. Consider factors such as the number of users for each system when deciding the group configuration.

Both network and group settings are required in order to use the system controller.

3.1.1 User Level and Access Level

■ User Level

The CBM-20A/20Alite System Controller has the user levels shown in the following table.

User level	Description
Administrator	Authorized to perform group settings (e.g., adding/removing components and users to/from the group and changing settings) in addition to the operations for which a Power User is authorized. Also authorized to forcibly log out users logged into the "Analysis Execution" application window ^{*1} , and to disable system locks.
PowerUser	Authorized to perform all the operations related to analysis (e.g., editing methods and sequences, executing, adding, and stopping analyses, and executing system checks) and to change system configurations. Also authorized to clear errors or forcibly stop analysis being performed by other users.
Operator	Authorized to edit analysis sequences, execute, add, and stop analyses, and execute system checks. When editing methods, can only edit flow rate of pump and cooler temperature of autosampler. Not authorized to clear errors or forcibly stop analysis being performed by other user.

*1 A user can only be forcibly logged out from a PC other than that on which they are logged in.

■ Access Level

The access levels are set for each system in a group and determine which users can log into each system. The Administrator is always authorized for access and all other users are authorized for access according to the default settings. Deny access if necessary.

3.1.2 Setting IP Addresses

■ Setting IP Addresses from the LC-20A

- 1 Link the system controller to the LC-20AB with an optical cable.
 An LC-30A/20A-series Solvent Delivery Module, Autosampler, or UV/UV-VIS/Fluorometric Detector can be used instead of the LC-20AB.
- 2 From the LC-20AB's [CBM PARAMETER] screen, press the [Enter] key and enter the parameters shown in the following table. The [CBM PARAMETER] screen is in the [VP] menu's [CALIBRATION] group.

Item	Description
SERIAL NUMBER	Displays the serial number of the system controller.
S/W ID:	Displays the control-unit version number and the model name for the system controller.
INTERFACE	Select the interface for connecting to a Chromatopac or LC workstation. This setting does not need to be changed when not connecting to a Chromatopac or LC workstation.
ETHERNET SPEED	Set the baud rate for communications with the switching hub. Under normal circumstances, set [0].
USE GATEWAY	Set [1] when using a default gateway. In this example, the gateway 192.168.8.101 is used and so set [1].
IP ADDRESS	In this example, set [192.168.8.161].
SUBNET MASK	In this example, set [255. 255. 255.0].
DEFAULT GATEWAY	In this example, set [192.168.8.101].
TRS MODE	When connecting to a Chromatopac or LC workstation, select the communication destination.

- 3 The new settings are enabled when the power is reset.

3. Preparation

■ Setting IP Addresses from Terminal Software

The procedure for setting IP addresses from terminal software, such as Windows' Hyper Terminal, is explained below. Connect the PC and system controller with an RS-232C cable.

1 Start up Hyper Terminal, specifying the COM port connected to the system controller.



Configure the following settings:

Bits per second: 9600
Data bits : 8
Parity : None
Stop bits : 1
Flow control : None

2 Reset the power while pushing the initialization button on the back of the system controller.

3 When characters are displayed on the screen, release the button.



CAUTION

If 5 seconds elapse after startup and no characters are displayed, release the button. If the button remains in the pressed position, the entire system will be initialized.

4 Following the instructions displayed on the screen, set the [IP address], [Subnet mask], [Default gateway], and [Ether speed]. Under normal circumstances, set the [Ether speed] to [0].

```
CBM - HyperTerminal
File Edit View Call Transfer Help
[Icons]
Release INIT-SW to enter boot menu or initialize all parameter
CBM-200 Loader version 1.00 (Apr  8 2006 14:15:07)
Press Enter key to proceed:

1.IP address      : 192.168.200.99
2.Subnet mask    : 255.255.255.0
3.Default gateway:
4.Ether speed    : 0 (Auto)
5.Boot parameter :
v.ROM Version Up from serial port

1-5:Change or 0,v:quit ? 1
{ (192.168.200.99) | '-'=Clear } -> 192.168.8.161

1.IP address      : 192.168.8.161
2.Subnet mask    : 255.255.255.0
3.Default gateway:
4.Ether speed    : 0 (Auto)
5.Boot parameter :
v.ROM Version Up from serial port

1-5:Change or 0,v:quit ? _
```

5 When the settings are completed, press the [0] key (quit) to save the settings.

6 The system controller reboots and the new settings are enabled.

3.1.3 Setting Group and System Names

An Administrator sets the group and system names.

- 1 Connect the system controller to the network.
- 2 Start Internet Explorer and enter the URL for the system controller. (URL for HPLC1: 192.168.8.161).
- 3 Click the system name in the "Status Summary" section.
The serial number of the system controller is displayed as the system name for new installations.
- 4 Login to the "Group Settings" application as an Administrator. (The user name and password for a new installation is "Admin".)
- 5 In the "System Administration" tab page, enter the parameters for [Create Group] and [Change System Name] in that order.

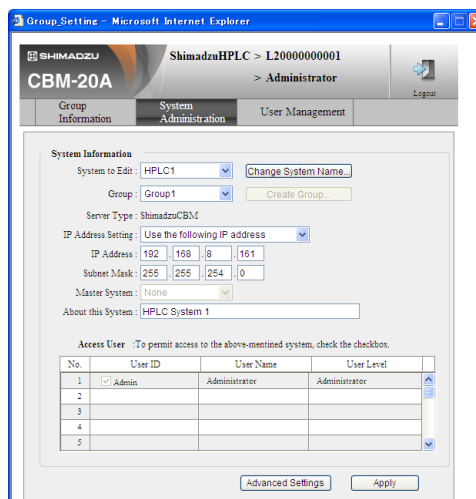

- 6 Click and close the "System Administration" tab page.



A group can be created only if there is no group set (i.e., [-] is displayed).



The groups displayed in the [Group] pull-down menu are all in the same subnet and so the system can be added to an existing group by selecting a group from the pull-down menu.



The system name can be changed only if there is no group set (i.e., [-] is displayed). To change the system name, clear the group settings (i.e., select [-]), click , and log in again.



If the IP address, subnet mask, or default gateway is changed, close all Internet Explorer windows according to the on-screen instructions, and reset the system controller power.

3. Preparation

3.1.4 Registering New Users

Use the following procedure to register new users.

- 1 Log into the "Group Settings" application as an Administrator, just as described in "3.1.3 Setting Group and System Names" P. 3-5.
- 2 Open the "User Management" tab page.

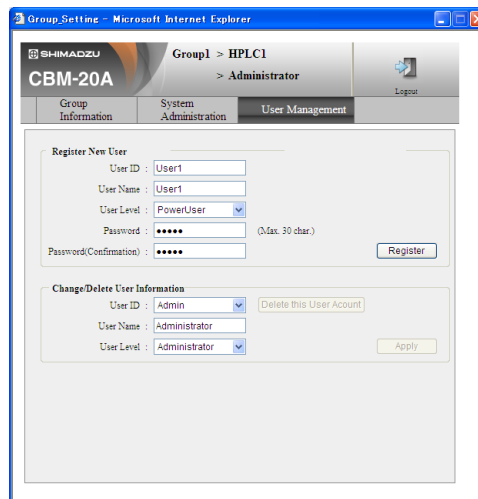

- 3 Enter the user ID, name, level and temporary password, then click .
- 4 Register all the users.

3.1.5 Group Information, System Administration, and User Management

This section provides details on Group Information, System Administration, and User Management.

■ Group Management

The following rules pertain to group management.

- In order to manage system components within a group, they are assigned a common group name.
- Up to 10 system components, including system controller, PDA detectors, and Multi Wavelength Detectors can be assigned to a single group.
- System components to be managed in the same group must be included within the same subnet of the network.
- When the PDA detector or the Multi Wavelength Detector is to be controlled by the system controller, the system controller, the PDA detector, and the Multi Wavelength Detector must be in the same group, and the master server name set for the PDA detector or the Multi Wavelength Detector must match the system name of the system controller.

■ User Management

The following rules pertain to user management.

- A maximum of 20 users can be registered under a single system controller.
- User information must be entered for each system controller.

■ Managing Users as a Group

The operations for managing users as a group are as follows.

- One of the system controllers in a group is designated as the master server.
- User registration and changes to user information and passwords are always made under this master server.
- When user information is changed, an Administrator copies the user information to the "Group Settings" application window of the master server.
- To copy user information, the user information from the master server is used to replace the user information for all the system controllers in a group. In this case, access levels of all users are set to enabled. However, if a user exists on the master server and targeted system controller, the access level is not changed for that user.

■ Initial Values

The settings at time of shipment are as follows:

Item	Description
IP address	192.168.200.99
Sub-net mask	255.255.255.0
Default gateway	Not used
Group name	Not registered (Shimadzu HPLC)
System name	Serial No.
Registered user	User ID: Admin
	Password: Admin

3.2 Starting the CBM-20A

Use the following procedure to start the CBM-20A.

- 1 Turn ON the power to the system controller and the components connected to it.
 -  Either turn ON the power to the system controller and the components simultaneously or turn ON the power to system controller last.
- 2 Turn ON the power to the PC used to control the system controller.
- 3 Start Internet Explorer.
- 4 Input the system controller's URL in the address bar. (<http://<IP address>/>)
The "Status" tab page is displayed.

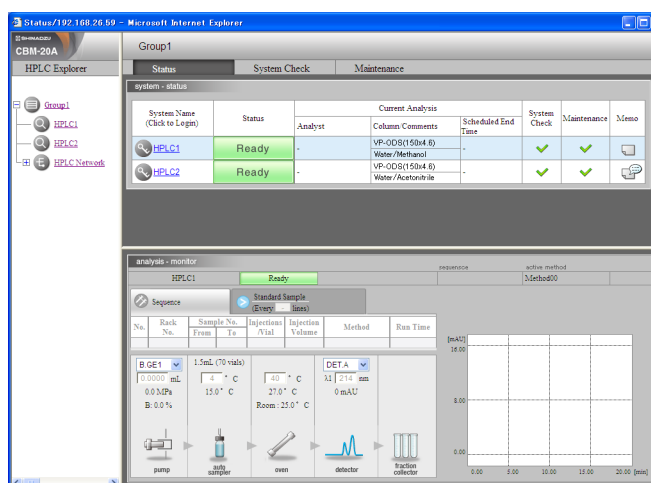

-  The system name of the system controller can be input instead of an IP address if the PC and the system controller are in the same subnet. (<http://<System Name>/>)

3.3 Determine the System Configuration

Determine the system configuration by setting the pumping mode for the solvent delivery module and the operation mode for the autosampler.

Also set the operation mode for the fraction collector, if there is one connected.

 The system configuration must be set by an Administrator or a Power User.

- 1 Click the appropriate icon or system name in the [System Name] column on the "Status" tab page in the "Status Summary" section.
The "Login" window is displayed.

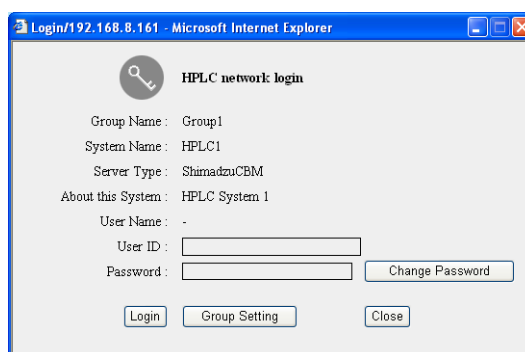

- 2 Input the user ID in the [User ID] field.
- 3 Input the password in the [Password] field.
- 4 Click .
The "Analysis Execution" application window is displayed.

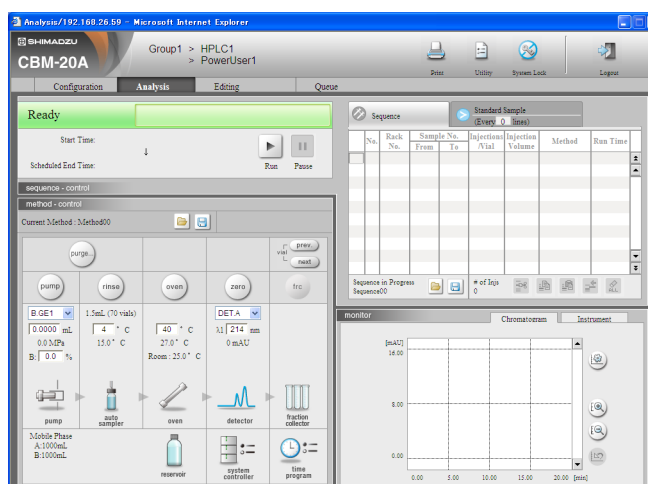

3. Preparation

- 5 Click the [Configuration] tab.
The "Configuration" tab page is displayed.

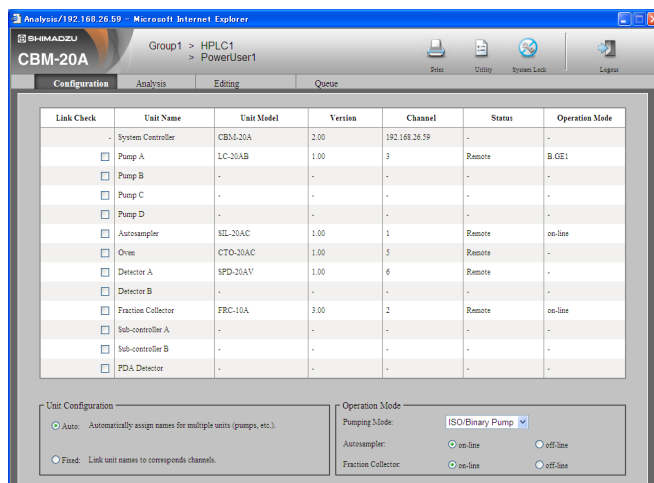

3.3.1 Checking Connections between the System Controller and Components

Check that the link status ("Status") for each of the components connected to the system controller is "Remote".

If the model name ("Unit Model"), version, and link status are not displayed, check the power supply of the component and verify that the link address setting ("LINK ADRS") and the remote-connector channel number agree for each component.

If the link status is "Local", verify that the local setting ("LOCAL") for each component is set to "Remote".



Changing the local setting ("LOCAL") for each component to "Local" makes it possible to use some of the functions that cannot be controlled by the system controller. Return this setting to "Remote" when using the system controller to control the component.

3.3.2 Selecting the Pumping Mode

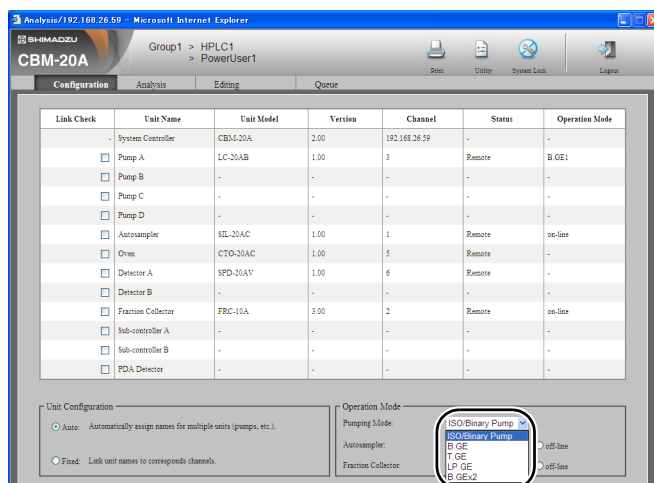

Specify the pumping mode for the solvent delivery module. The 5 modes described in the following table are available.

3.3 Determine the System Configuration

Select the pumping mode from the [Pumping Mode] pull-down menu in the "Operation Mode" section at the bottom right of the "Configuration" tab page.

Pumping mode	Description
ISO/Binary Pump	Select this mode to use the isocratic pump connected to "Pump A" in isocratic flow mode or use the LC-20AB Binary Pump to "Pump A".
B.GE	Select this mode to use the binary gradient mode in combination with 2 isocratic pumps connected to Pump A and B. This enables the high-pressure gradient pumping of 2 solvents.
T.GE	Select this mode to use the ternary gradient mode in combination with 3 isocratic pumps connected to Pump A, B, and C. This enables the high-pressure gradient pumping of 3 solvents.
LP.GE	Select this mode to use the low-pressure gradient mode with an isocratic pump connected to Pump A. This enables the low-pressure gradient pumping of 4 solutions.
B.GEx2	Select this mode to use binary gradient with 2 flow lines and a combination of 2 isocratic pumps for each flow line. In this case, 4 pumps are required.



The "Isocratic pump" refers to a pump used in the LC-30A/LC-20A series except LC-20AB.

The pumping-mode selection is reflected in the [Operation Mode] column of the configuration table in the following way.

Pump	Pumping mode				
	ISO/Binary Pump	B.GE	T.GE	LP.GE	B.GEx2
Pump A	ISO1/B.GE1	B.GE1	T.GE1	LP.GE	B.GE1
Pump B	ISO2/B.GE2	B.GE1	T.GE1	ISO2/B.GE2	B.GE1
Pump C	ISO3/B.GE3	ISO3/B.GE3	T.GE1	ISO3/B.GE3	B.GE3
Pump D	ISO4/B.GE4	ISO4/B.GE4	ISO4/B.GE4	ISO4/B.GE4	B.GE3



Pump allocation:

- Allocate isocratic pumps to the gray boxes in the table. Do not allocate different pump models.
- If isocratic pumps are allocated to the white boxes in the table, operation will be in ISO mode, and if binary pumps are allocated to these boxes, operation will be in B.GE mode.



The LC-20AB can only be used as a binary pump. It cannot be used in place of an isocratic pump. More specifically, correct operation is not possible in the following cases.

- The LC-20AB is connected as pumps A and B in B.GE mode.
- The LC-20AB is connected as pumps A, B, and C in T.GE mode.

3. Preparation

- The LC-20AB is connected as pump A in LP.GE mode.
- The LC-20AB is connected as pumps A, B, C, and D in B.GEx2 mode.



Even if a pump which is not compatible with a low-pressure gradient (such as the LC-10AS) is connected in LP.GE mode, it will not operate properly.

3.3.3 Selecting the Unit-name Allocation Method

Unit Configuration

Auto: Automatically assign names for multiple units (pumps, etc.).

Fixed: Link unit names to corresponds channels.

Set the relationship between the unit names and link addresses (remote-connector channel numbers) used for the components connected to the system (e.g., pumps and detectors). This can be done by selecting either [Auto] or [Fixed] in the "Unit Configuration" section at the bottom left of the "Configuration" tab page. In normal circumstances, select [Auto] before creating a new configuration and then select [Fixed] after the configuration has been created.



Some functions will not operate properly if the configuration is changed with [Fixed] selected.

■ Allocation with [Auto] Selected

The pumps are given letters A, B, C, and D in order of increasing link address. Allocation of letters for detectors is done in the same way. If the CBM-20Alite is incorporated in an LC-30A/20A-series solvent delivery module, this delivery module will always be pump A.

■ Allocation with [Fixed] Selected

Select [Fixed] to fix the relationship between all the components in the system.

4 Basic Operation

4.1 Overall Flow of Operation

The basic overall flow of operations for the following typical system configuration is described below.

- Pump : LC-20AB
- Autosampler : SIL-20AC
- Column oven : CTO-20AC
- Detector : SPD-20AV



There is no fraction collector connected in this system configuration.

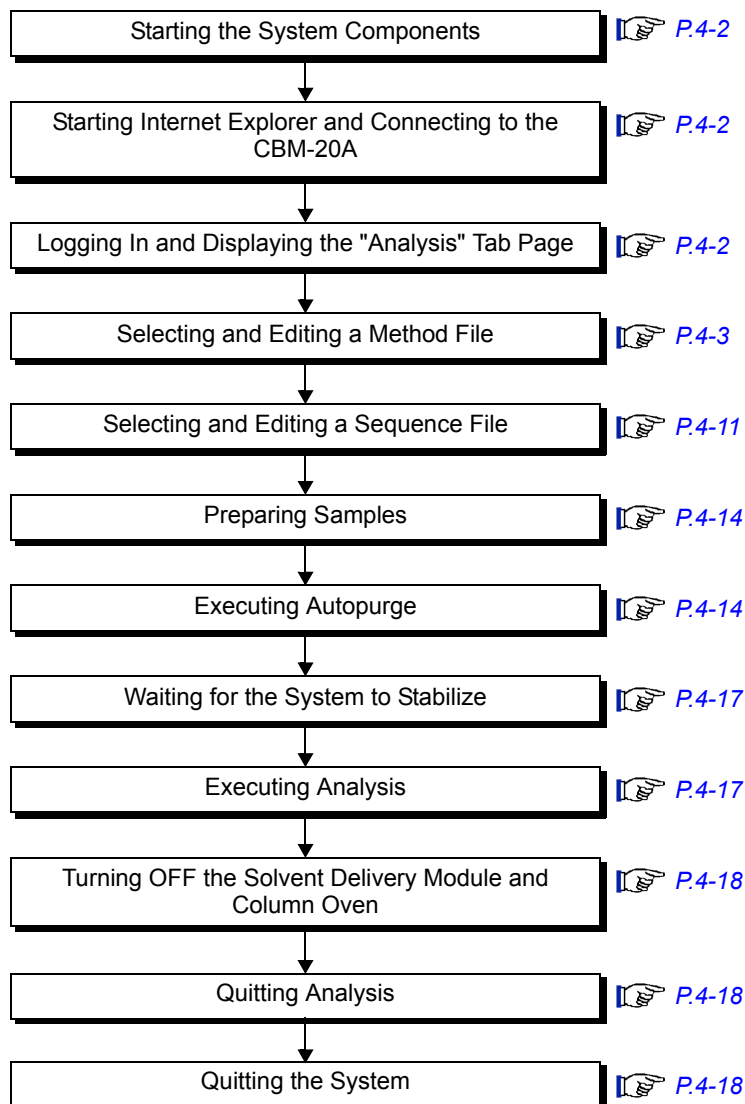

 If a fraction collector is used, refer to the Instruction Manual (detailed manual) "5.6 Analysis Using Fraction Collectors".

4.2 Starting the System Components

Turn ON the power to the solvent delivery module, autosampler, column oven, detector, system controller, and PC.

4.3 Starting Internet Explorer and Connecting to the CBM-20A

Start Windows Internet Explorer and connect to the system controller. The "Status" tab page is displayed.

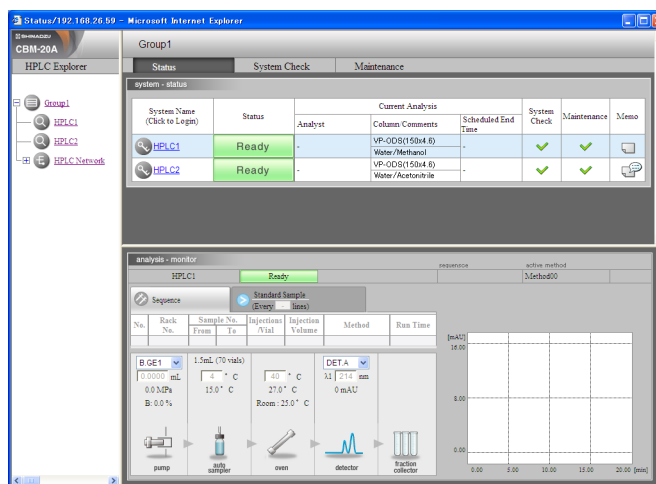

4.4 Logging In and Displaying the "Analysis" Tab Page

Login to the system that will be used to perform analysis. The "Analysis Execution" application window is displayed.



Login is not possible if, for example, another user is logged in or the system is connected to LC workstation.



["2.4 "Login" Window" P. 2-8](#)

4.5 Creating Method Files

Parameters for all the components are set and saved as method files. To start analysis, retrieve an appropriate method file to be used as a basis for the analysis procedure.

Method files can be created in either the "Analysis" tab page or the "Editing" tab page of the "Analysis Execution" application. Although the creation method is the same for both pages, the functions of the pages differ in the following way.

- The method file displayed in the "Analysis" tab page is the file that is currently used. The method-file contents configured on this page are applied directly to all the components.
- In the "Editing" tab page, method files that are not currently being used can be selected and edited.

This section describes the method for creating a new method file from the "Analysis" tab page below.



Configuration parameters are not included in method parameters.



Among the autosampler's method parameters, the parameters that depend on the sample rack are common to all method files. If these parameters are changed in one method file, these changes are applied to all other files (No. 0 to 19).

4.5.1 Selecting Method Files

In order to create a new method file, it is first necessary to select a method file and load it.

1

Click the [Analysis] tab in the "Analysis Execution" application window. The "Analysis" tab page is displayed.

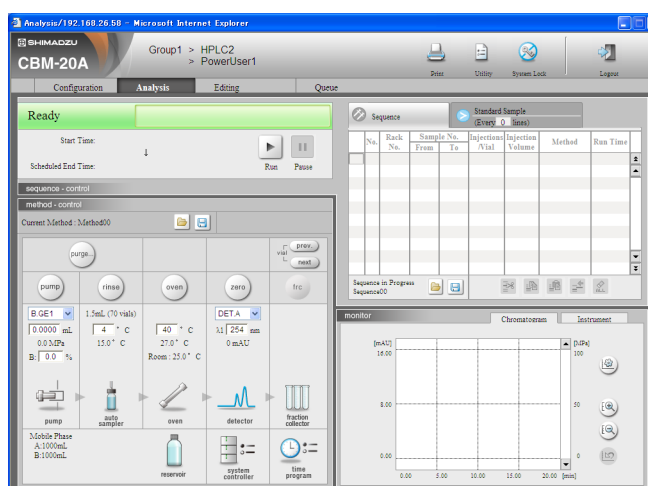

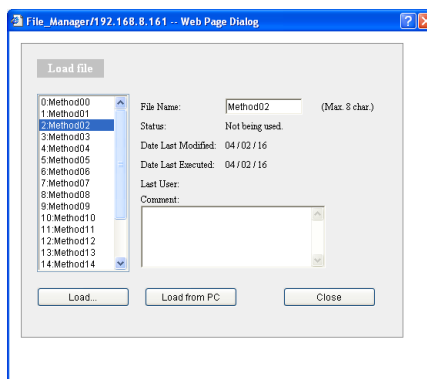

4. Basic Operation

- 2 Click  on the right of the current method filename.
The "Load File" window is displayed.



- 3 Select a file from the list on the left of the window.
The name of the selected file is displayed in the [File Name] field.

 Up to 20 method files can be saved. "Method00" to "Method19" are used as the default filenames. (The numbers in front of the files are the file numbers; file numbers 0 to 19 are allocated to the files.)



 Changing filenames:
The names of the method files can be changed. Select the [File Name] field and input a filename of no more than 8 characters.

- 4 Input a comment if necessary.

 Comments can contain up to 250 characters.

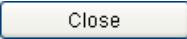
- 5 Click  .
The window closes and the name of the selected file is displayed in the "Analysis" tab page as the current method.

 Click  to close the window without loading a file.

 For details on  , refer to the *Instruction Manual (detailed manual)* "5.7 Managing Files".

4.5.2 Editing the "Method Parameter" Window

Method files are edited from the "Analysis" tab page using the "Pump", "Autosampler", "Oven", "Detector", "Fraction Collector", and "System Controller" tab pages in the "Method Parameter" window.

■ Displaying the "Method Parameter" Window

Click a component icon in the "Analysis" tab page to display the tab page in the "Method Parameter" window for that component. If the tab page for another component is displayed, click the tab for the desired component in the same window.

There is also a "Configuration Parameter" window containing tab pages for each component except the fraction collector. Click  in the tab page of the "Method Parameter"

window to display the tab page for that component in the "Configuration Parameter" window. The "Fraction Collector" tab page does not have a **Configuration...** button.



If a value that is out of the acceptable range is entered, the data returns to its original value and is highlighted. Input a value that is within range.

4.5.3 Parameters for the Solvent Delivery Module

Enter the solvent delivery module parameters, such as flow rate and minimum/maximum pressure.

The displayed parameters may vary with the type of solvent delivery module and the pumping mode set in the "Pump" tab page in the "Configuration Parameter" window.



For details on the various parameters and the setting ranges, minimum units, units, and default values for the parameters, refer to the Instruction Manual (detailed manual) "5.12.1 Pump".

1



Click in the "Analysis" or "Editing" tab page.

The "Pump" tab page in the "Method Parameter" window is displayed.

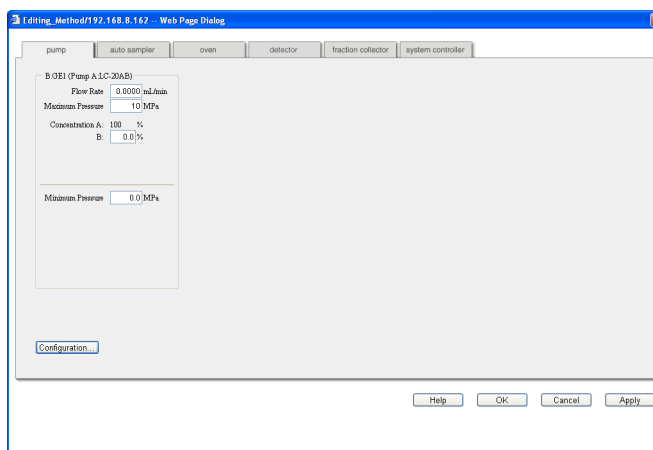

The contents of the "Pump" tab page vary depending on the pumping mode and the number of solvent delivery modules that are connected.

2

Set the method parameters for the pump.



3

Click **Configuration...**.

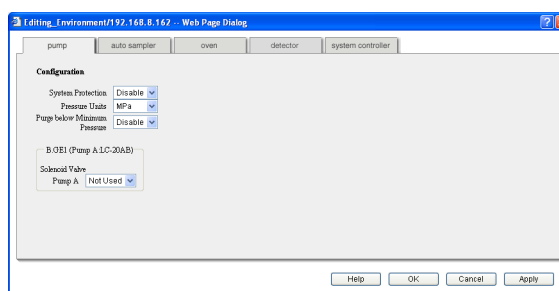
The "Pump" tab page in the "Configuration Parameter" window is displayed.

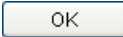
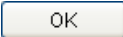
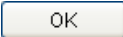

4. Basic Operation

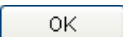
- 4 Set the configuration parameters for the pump.
 -  If [Used] is selected for [Solenoid Valve] and  is clicked in the "Pump" tab page of the "Configuration Parameter" window, the solenoid valve PSV is displayed in the "Pump" tab page of the "Method Parameter" window.
- 5 Click  when setting is complete.
The display returns to the "Method Parameter" window.
- 6 Click .
The "Analysis" tab page is displayed.
 -  To set parameters for another component, click the tab for that component instead of clicking . The corresponding tab page is displayed.

The parameters are set for the autosampler, column oven, and detector using the same procedures.

4.5.4 Parameters for the CBM-20A

Enter the CBM-20A parameters, such as the event output and serial interface.

-  For details on the various parameters and the setting ranges, minimum units, units, and default values for the parameters, refer to the *INSTRUCTION MANUAL (detailed manual)* "5.13.6 System Controller".

- 1 Click  in the "Analysis" tab page.
The "System Controller" tab page in the "Method Parameter" window is displayed.

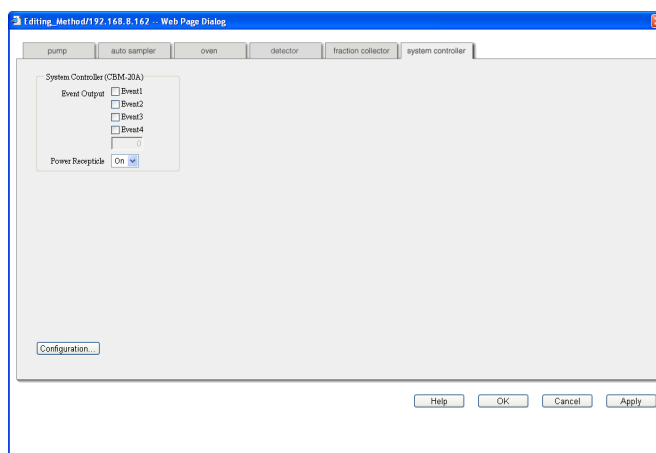

- 2 Set the method parameters for the system controller.

- 3 Click **Configuration...**.
The "System Controller" tab page in the "Configuration Parameter" window is displayed.

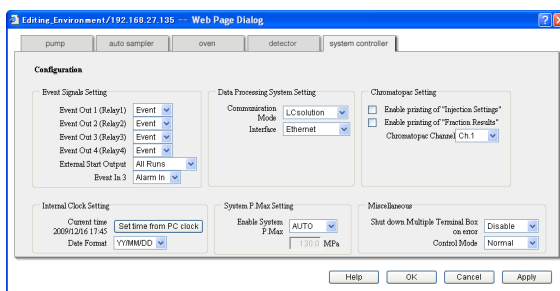

- 4 Set the configuration parameters for the system controller.

- 5 Click **OK** when setting is complete.
The display returns to the "Method Parameter" window.

- 6 Click **OK**.
The "Analysis" tab page is displayed.

 To set parameters for another component, click the tab for that component instead of clicking **OK**. The corresponding tab page is displayed.

4.6 Gradient Analysis Using Time Programs

With this system controller, the functions (e.g., parameters and commands) of components can be set as time programs. Creating a time program enables control that is dependent on the elapsed analysis time. Each line of a time program includes data on the time, the functions for each component, and other settings. Time programs are stored as part of method files.

Be sure to use a time program with gradient analysis.

Time programs can be created in either the "Analysis" tab page or the "Editing" tab page of the "Analysis Execution" application. The creation method is the same for both pages.

This section describes the method for creating a new time program from the "Analysis" tab page.

4. Basic Operation

4.6.1 Displaying the "Time Program" Window

Use the following procedure to display time programs.

- 1 Click the [Analysis] tab in the "Analysis Execution" application window. The "Analysis" tab page is displayed.

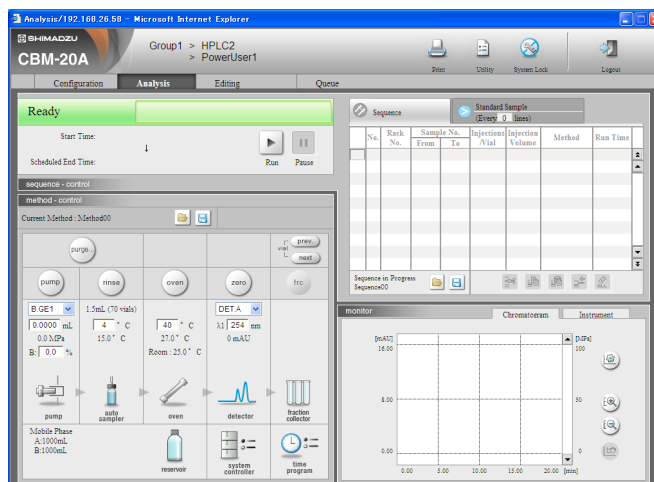

- 2 Select the method file for which the time program is to be created.
 The selection method is the same as the one described in "Selecting Method Files".

 ["4.5 Creating Method Files" P. 4-3](#)

- 3 Click  in the "Method" section.



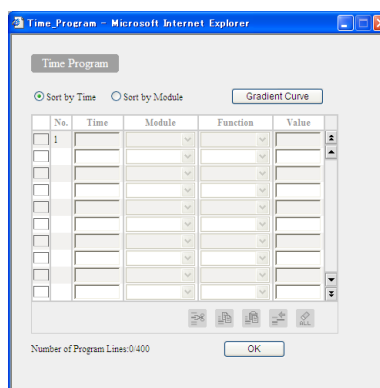

The "Time Program" window is displayed.

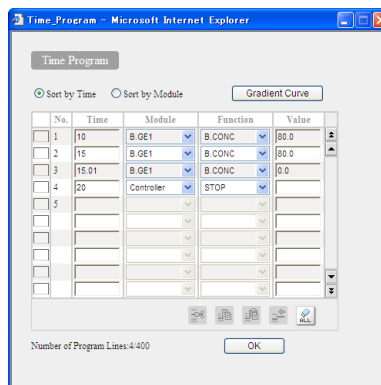

4.6.2 Creating Time-program Tables

Create a time-program table using the "Time Program" window. Input program settings, such as run times and functions, in the time-program table.



- 1 Input the run time for the first line in the [Time] column and press the [Tab] key. It becomes possible to make selections from the pull-down menus in the [Module] and [Function] columns. If input is required in the [Value] column, the default value for that parameter is displayed.
- 2 Select a component from the pull-down menu in the [Module] column.
- 3 Select a function from the pull-down menu in the [Function] column.
- 4 If the function is a parameter (i.e., a value is required), input a value within the setting range for the parameter.
- 5 The input method for line 2 and subsequent lines are the same as for line 1. Note that the default values displayed in the [Module], [Function], and [Value] columns are the same as the input values for the previous line.
 -  Up to 400 lines can be input in a time program.
 -  When editing a time program, if the system configuration has changed since the time program was created, functions for components that no longer exist cannot be changed. (They can, however, be deleted.)
 -  The procedure for editing time programs is the same as that for editing sequence tables.
- 6 Click .
 - The time program is saved to the selected method file and the "Time Program" window closes.
 -  To perform analysis using time programs, select the appropriate method files in the sequence table's [Method] column.
 -  For details on analysis procedures, refer to "4.1 Overall Flow of Operation" P. 4-1.

4. Basic Operation

4.6.3 Time-program Setting Example

A setting example for time programs is provided below.

Gradient mode : Binary gradient (B.GE1)

Change in concentration : After 10 minutes have elapsed, the concentration of mobile phase B is changed to 80 % and is held at 80 % until a total of 15 minutes have elapsed. After a total of 15.01 minutes have elapsed, the concentration of mobile phase B is reduced to 0 %.

One cycle is 20-minutes long.

The setting for mobile phase B (B.CONC) in the method is 0 %.

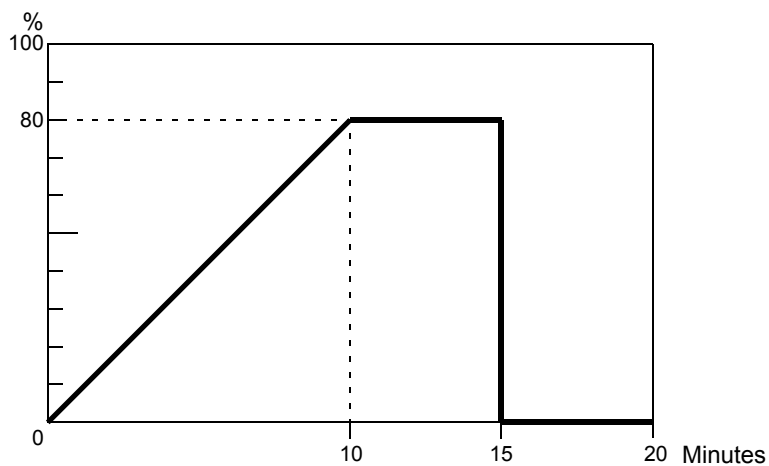

Fig. 4.1

Set the time program for this operation in the way shown in the following table.

No.	Time	Module	Function	Value
1	10	B. GE1	B. CONC	80.0 %
2	15	B. GE1	B. CONC	80.0 %
3	15.01	B. GE1	B. CONC	0.0 %
4	20	Controller	STOP	



Be sure to set the STOP command for the "Controller" at the end of the time program.

4.7 Creating Sequence Files

Analysis sequences are set and stored as sequence files, which are used when performing analysis.

Sequence files can be created in either the "Analysis" tab page or the "Editing" tab page of the "Analysis Execution" application. Although the creation sequence is the same for both pages, the functions of the pages differ in the following way.

- The sequence file displayed in the "Analysis" tab page is the file that is currently used. When analysis starts, it runs in accordance with the contents of the sequence file specified in this screen.
- In the "Editing" tab page, sequence files that are not currently being used can be selected and edited.

This section describes the method for creating a new sequence file from the "Analysis" tab page.

4.7.1 Selecting Sequence Files

In order to create a new sequence file, it is first necessary to select a sequence file and load it.

- 1 Click the [Analysis] tab in the "Analysis Execution" application window. The "Analysis" tab page is displayed.

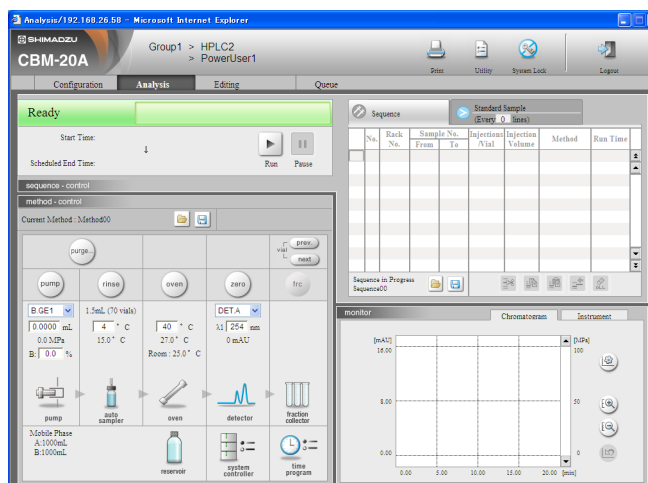

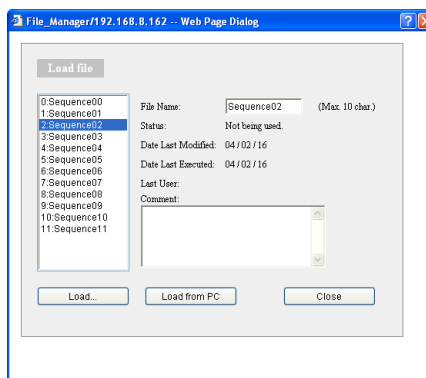

4. Basic Operation

- 2 Click  on the right of the current sequence filename.
The "Load File" window is displayed.



- 3 Select a file from the list on the left of the window.
The name of the selected file is displayed in the [File Name] field.

 Up to 12 sequence files can be saved. "Sequence00" to "Sequence11" are used as the default filenames. (The numbers in front of the files are the file numbers; file numbers 0 to 11 are allocated to the files.)

 Changing filenames:
The names of the sequence files can be changed. Select the [File Name] field and input a filename of no longer than 10 characters.

- 4 Input a comment if necessary.

 Comments can contain up to 250 characters.

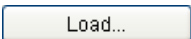
- 5 Click  .
The window closes and the name of the selected file is displayed in the "Analysis" tab page as the current sequence.

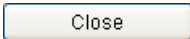
 Click  to close the window without loading a file.

4.7.2 Creating Sequence Tables

Create a sequence table using a sequence file. Input analysis conditions, such as vial numbers and injection volumes, in the sequence table.

- 1 If the connected autosampler is the SIL-30A/20A series autosampler, input the rack number in the [Rack No.] field and press the [Tab] key.
The default settings [1], [1], [1], [10], [-], and [1.00] are displayed respectively in the [From] and [To] columns under [Sample No.], the [Injections/Vial] column, the [Injection Volume] column, the [Method] column, and the [Run Time] column.

 The default setting for [Injection Volume] varies depending on the connected autosampler.

 If the connected autosampler is the SIL-10ADvp/10A/10Ai/10AXL/10AF/10AP, no value is displayed in the [Rack No.] column.

 It is possible to set [-] in the [Rack No.] and [From] columns. In this case, analysis operation is performed in accordance with the [Method] setting for that line but injection operation is not performed by the autosampler.

2 Make corrections as required.

When using a time program for analysis, select the required method file from the pull-down menu. When a method file is selected, the setting shown in the [Run Time] column changes to [-]. When a method file is not selected, enter the analysis time in the [Run Time] column.

 Two or more method files can be selected for one analysis sequence.

	Setting item	Description	
①	[Sequence] tab	Click to display the table for the sequence file.	
②	[Standard Sample (Every n/ lines)] tab	Click to display the table for the standard sample injection (repeat-injection).	
③	Sequence in Progress	Displays the currently selected filename.	
	No.	Displays the line number. The system controller automatically allocates numbers 1 to 100 in order.	
	Rack No.	Input the number of the rack used. This setting is not possible if a model other than the SIL-30A/20A series is connected.	
	Sample No.	From	Input the vial number of the first sample to be analyzed.
		To	Input the vial number of the last sample to be analyzed.  For details on rack and sample numbers, refer to "5.14 List of Rack Numbers" on the Instruction manual (detailed manual).
	Injections/Vial	Input the number of injections for each vial. The setting range is 1 to 99 and the default setting is 1.	
	Injection Volume	Input the volume (μL) for each injection. The default value and setting range vary with the autosampler model.	
	Method	Select the method file used for analysis. "Method00" to "Method19" can be selected as the method file. If [-] is selected, analysis is performed with the settings for the current method. The default setting is [-].	
Run Time	If no method file is used, or if [-] is selected under [Method], input the analysis time. Setting range: 0.01 to 9999.90 (minutes) Setting unit: 0.01 Default setting: 1.00		

- 3** The input method for line 2 and subsequent lines is the same as for line 1. Note that the values displayed in the [To] column under [Sample No.], the [Injection/Vial] column, the [Injection Volume] column, the [Method] column, and the [Run Time] column are the same as the input values for the previous line.

 Up to 100 lines can be input in a sequence table. The sequence is composed in order starting from line 1. It is not possible to skip lines.
- 4** When the required settings have been made in the sequence table, the table is saved as a sequence file.

4.8 Preparing Samples

Place the samples to be analyzed in the autosampler rack and close the door.

4.9 Executing Autopurge

The Autopurge function replaces the solvents in the flow line from the suction filter to the autosampler and in the autosampler's measuring pump with the mobile phase used for analysis and the rinse solution.

 **CAUTION**

Be sure to confirm that temperature control for the column oven is OFF before executing autopurge.

If it is ON, click  to turn temperature control OFF.

- 1 Click  in the "Method" section.
The "Autopurge" window is displayed.

 The displayed items vary with the system configuration.

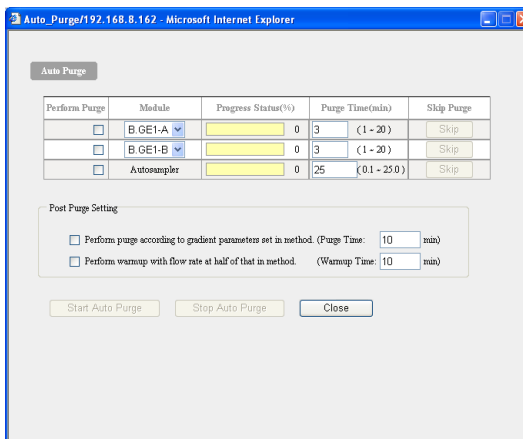

Perform Purge	Module	Progress Status(%)	Purge Time(min)	Skip Purge
<input type="checkbox"/>	B.GE1-A	0	3 (1 - 20)	Skip
<input type="checkbox"/>	B.GE1-B	0	3 (1 - 20)	Skip
<input type="checkbox"/>	Autosampler	0	25 (0.1 - 25.0)	Skip

Post Purge Setting

Perform purge according to gradient parameters set in method. (Purge Time: 10 min)

Perform warmup with flow rate at half of that in method. (Warmup Time: 10 min)

Start Auto Purge Stop Auto Purge Close

- 2 Confirm that the boxes in the [Perform Purge] column corresponding to the mobile phase to be purged and the autosampler are selected. If they are not, click on the appropriate boxes.

- 3 Input the appropriate purge time (in minutes) for the solvent delivery module in the [Purge Time] column.

 The setting range is 1 to 20 minutes. (The setting unit is 1 minute and the default setting is 3 minutes.)

- 4 Input the appropriate purge time (in minutes) for the autosampler in the [Purge Time] column.

 The setting range varies depending on the connected autosampler.
SIL-30AC/30ACMP:
0.0 to 25.0 (The setting unit is 0.1 minutes and the default setting is 10 minutes.)

Other than SIL-30AC/30ACMP (such as SIL-20A/20AC):
0.1 to 25.0 (The setting unit is 0.1 minutes and the default setting is 25 minutes.)

If the connected autosampler is the SIL-30AC/30ACMP, set the purge execution time for each rinse solution because purge operation with multiple rinse solutions is possible. For the rinse solution not used for purge operation, set "0" for the purge execution time.

- 5 To purge the flow line at the flow rate and concentration set in the method file after autopurge is completed, click the [Perform purge according to gradient parameters set in method.] box.

In this case, the mobile phase is discharged from the autosampler's drain.

 The setting range for [Purge Time] is 1 to 120 minutes. (The setting unit is 1 minute and the default setting is 10 minutes.)

6 To pump the mobile phase under the conditions set in the method file after autopurge is completed, click the [Perform warmup with flow rate at half of that in method.] box. In this case, half of the value set in the method file is used.

 The setting range for [Warmup Time] is 1 to 120 minutes. (The setting unit is 1 minute and the default setting is 10 minutes.)

7 Click .
The progress of the purge operation is indicated in the [Progress Status] column. Settings cannot be changed during purge execution.

 The purge is not executed if the door of the autosampler is open. Settings cannot be changed during purge execution.

Click to stop purge operation for the corresponding component and execute the next step. Click to forcibly stop autopurge operation.

8 Click .
The "Autopurge" window closes.

 Autopurge operation will continue even if the "Autopurge" window is closed during execution.



During autopurge, the status display in the "Analysis" tab page changes in the following order: [A.Purge], [B.Purge], [SILPurge], [InitConcFlow], [WarmUp]. It returns to [Ready] when autopurge is completed. (The status display varies with the autopurge settings.)

4.10 Waiting for the System to Stabilize

After autopurge is completed, click  and  in the "Method" section to start solvent delivery with the solvent delivery module and temperature control with the column oven.

 If warmup is executed as part of the autopurge process, the pump will already be ON.

Look at the chromatogram in the "Monitor" section and ensure that the baseline of the detector as well as pump pressure is stable. Click  in the "Method" section to set the data to zero (the baseline of the detector to "0").

Click the  or  button at the chromatogram to enlarge or reduce the chromatogram of the detector in the Y-axis direction. Click the  button to display the "Chromatogram Setting" window, and you can set whether or not to show the pump pressure and change the maximum and minimum pressure values.

 For details about the "Chromatogram Setting" window, refer to "2.7.1 "Analysis" Tab Page" in the *CBM-20A Instruction Manual (detailed manual)*.



 The default length of the chromatogram's time axis is 20 minutes. When analysis starts, however, it changes to a value in the range 1 to 120 minutes in accordance with the analysis time (as determined by the "Run Time" setting or the time program's STOP command).

4.11 Executing Analysis

Start analysis of the samples.

1 Click .

[Run] changes to [Stop] and analysis is performed in accordance with the sequence settings. When analysis is completed, the status display changes to [Ready].

 Click  to stop analysis. If the status is [Stop], rinse the autosampler's needle by clicking .

4.12 Turning OFF the Solvent Delivery Module and Column Oven



When analysis is completed, click  and  in the "Method" section to stop solvent delivery and temperature control.

4.13 Quitting Analysis

Log out from the "Analysis Execution" application, then close "Group Monitor" application.

- 1 Click  in the "Analysis Execution" application window. The following window is displayed.

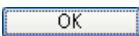

- 2 Click . The "Analysis Execution" application window closes.
- 3 Click  at the top right of the "Group Monitor" application window.
 If the "Group Monitor" application window is not displayed, display it by selecting [Group Monitor] from the task bar at the bottom of the window.
The "Group Monitor" application and the Internet Explorer windows are closed.

4.14 Quitting the System

Turn OFF the power to the components and quit windows.

- 1 Turn OFF the power to the system controller, solvent delivery module, autosampler, column oven, and detector.
- 2 Close Windows.

5 Maintenance



5.1 Checking the System

System checks can be executed for LC-30A/LC-20A/LC-10Avp-series products connected to the system controller and the results can be displayed. It is also possible to display the results of system checks for all the LC systems in a group in tabular format.

System checks are executed from the "System Check" tab page in the "Status Summary" section.

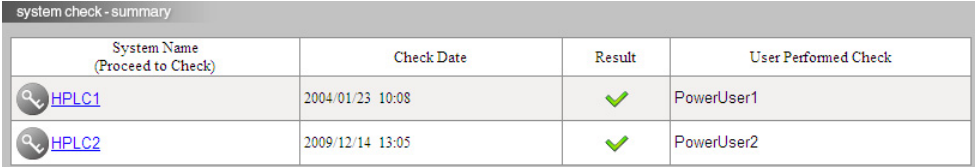
- 1 Click the [System Check] tab in the "Status Summary" section.
The "System Check" tab page is displayed.



System Name (Proceed to Check)	Check Date	Result	User Performed Check
 HPLC1	2004/01/23 10:08	✓	PowerUser1
 HPLC2	2009/12/14 13:05	✓	PowerUser2

- 2 Click the name (or ) of the system to be checked.
The "Login" window is displayed.

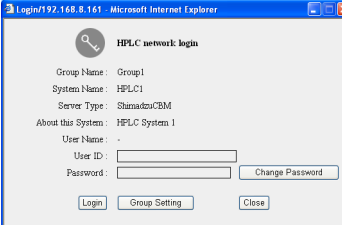

Group Name : Group1
System Name : HPLC1
Server Type : ShimadzuCBM
About this System : HPLC System 1

User Name : -
User ID :
Password :

- 3 Input the user ID and password and click .
The "System Check" application window is displayed.

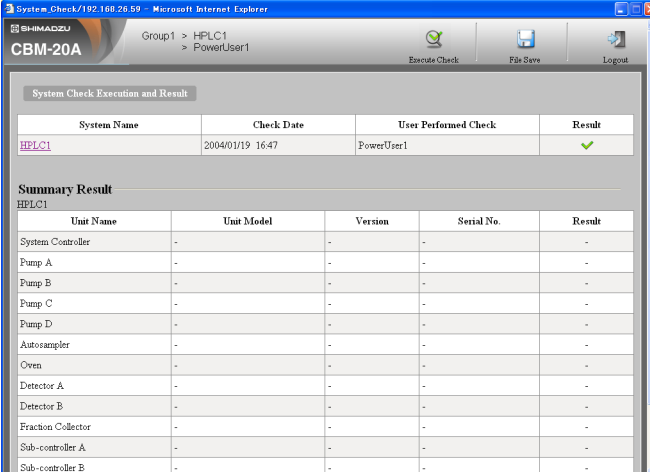

System Name	Check Date	User Performed Check	Result
HPLC1	2004/01/19 16:47	PowerUser1	✓

Summary Result



Unit Name	Unit Model	Version	Serial No.	Result
System Controller	-	-	-	-
Pump A	-	-	-	-
Pump B	-	-	-	-
Pump C	-	-	-	-
Pump D	-	-	-	-
Autosampler	-	-	-	-
Oven	-	-	-	-
Detector A	-	-	-	-
Detector B	-	-	-	-
Fraction Collector	-	-	-	-
Sub-controller A	-	-	-	-
Sub-controller B	-	-	-	-

The results of the previous system check are displayed. (Only the results of system checks performed after power is turned ON are displayed in the "Summary Result" table.)

4 Click .

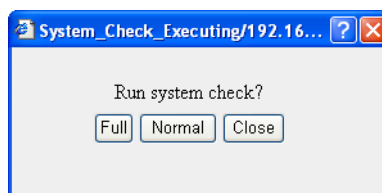
The following window is displayed.



-  There are 2 types of system check: [Full] and [Normal]. If [Full] is selected, the lamp energy for the UV/UV-VIS detector light source and wavelength accuracy for the UV/UV-VIS detector and the fluorometric detector (RF-20Axs only) light sources are checked. These items are not checked as part of the [Normal] system check.
-  Wavelength accuracy check cannot be executed with the SPD-M20A/M30A/30AM from the CBM-20A, but data of the SPD-M20A/M30A/30AM can be collected and check results displayed.
-  System check can be executed for all LC-30A/LC-20A/LC-10Avp-series components (except LC-10Avp-series Sub controllers).

5 Click or as required.
The following window is displayed and the system check starts.

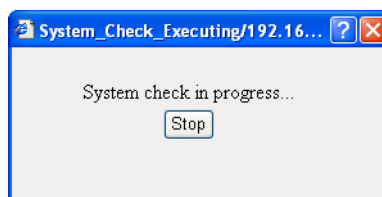

-  Click to stop the system check. Depending on the system, the processing required to stop the system check may take 1 or 2 minutes.

When the system check is completed, the "System Check Executing" window closes and the results of the system check are displayed.

5.1.1 System Check Results

The results of the system check are divided into the following 3 tables: the "System Check Execution and Result" table, the "Summary Result" table, and the "Detailed Results" table.

■ "System Check Execution and Result" Table

The check results for the whole system are displayed.

①	②	③	④
System Name	Check Date	User Performed Check	Result
HPLC1	2004/01/19 16:47	PowerUser1	✔

	Display item	Description
①	System Name	Displays the names of the systems in the group. Click on a name to jump to the "Summary Result" table for that system.
②	Check Date	Displays the year, month, day, and time of the last check.
③	User Performed Check	Displays the name of the user who executed the system check.
④	Result	Result for the LC system.
	✔	Displayed if the system passed the check.
	!	Displayed if there is a replaceable part that has passed its recommended replacement date.
	✘	Displayed if the system failed the check.
	-	Displayed if the system check has not been executed.



If or is displayed in the "Result" column:

Replace parts or do whatever is necessary to remove the cause of the problem with reference to the instruction manual for the relevant component.



When the power is turned OFF, only the check results for the system as a whole are saved, and the data for the "Summary Result" table and the "Detailed Results" table is lost.

■ "Summary Result" Table

All the components connected to the system are displayed along with their check results.

Unit Name	Unit Model	Version	Serial No.	Result
System Controller	CBM-20A	2.00	L20224200001	✓
Pump A	LC-20AB	1.00	L20124100001	✓
Pump B	-	-	-	-
Pump C	-	-	-	-
Pump D	-	-	-	-
Autosampler	SL-20AC	1.00	L20174100001	✓
Oven	CTO-20AC	1.00	L20214100001	✓
Detector A	SPD-20AV	1.00	L20144100001	✓
Detector B	-	-	-	-
Fraction Collector	FRC-10A	3.00	-	-
Sub-controller A	-	-	-	-

	Display item	Description
①	Unit Name	Displays the names of the components connected to the system. Click on a name to jump to the "Detailed Results" table (if there is one) for that component.
②	Unit Model	Displays the model names of the connected components.
③	Version	Displays the version numbers of the connected components.
④	Serial No.	Displays the serial numbers of the connected components.
⑤	Result	Displays the system-check results for the connected components. The meanings of the displayed symbols are as previously described. [-] is displayed if there is no check item.

■ "Detailed Results" Table

Detailed system-check results for individual components are displayed.

Detailed Results				
System Controller		CBM-20A		
Item	Check Date	Result of Check		Result
		Result Value	Criterion Value	
UNIT NAME	-	CBM-20A	-	-
REPORT DATE	2004.01.23 10:08	-	-	-
SERIAL NUMBER	-	L20224200001	-	-
ROM VERSION	-	V1.00	-	-
IP ADDRESS	-	192.168.26.59	-	-
SUBNET MASK	-	255.255.254.0	-	-
DEFAULT GATEWAY	-	192.168.26.201	-	-
MAC ADDRESS	-	00:E0:96:01:00:2E	-	-
ROM CHECK	2004.01.23 10:08	-	-	✓
RAM CHECK	2004.01.23 10:08	-	-	✓
TOTAL OP TIME (hr)	2004.01.23 10:08	123	-	-

	Display item	Description
①	Item	Displays the system-check item.
②	Check Date	Displays the year, month, day, and time of the last check.
③	Result Value and Criterion Value	Displays the value obtained for each check item along with a value representing the criterion for that item.
④	Result	The check results for each item are displayed. The meanings of the displayed symbols are as previously described.

5.1.2 Saving the Results of System Checks

System-check results can be saved as text files. The saved data can be viewed and edited with applications such as Microsoft Excel.

To store the results, click  on the "System Check" application window.

5.2 Checking Maintenance Information

Information required for maintenance, such as information on the solvent delivery module plunger seal, the autosampler needle and rotor seal, and the illumination time of the detector lamp, can be checked in the "Maintenance" tab page.

5.2.1 Displaying the "Maintenance" Tab Page

Click the [Maintenance] tab in the "Status Summary" section to display the "Maintenance" tab page.

The message [Collecting maintenance data...] is displayed and the maintenance information for the systems in the group is displayed in the "Maintenance" tab page.

5.2.2 "Maintenance" Tab Page Display



Details on the items displayed in the "Maintenance" tab page are provided below.



The displayed items vary with the type of solvent delivery module, autosampler, and detector connected.

Unit Name	Unit Model	Item	Result	Present / Recommendation	Date Last Replaced
HP_C1					
Pump A	LC-20AB	A L SEAL [L]	✓	2 / 90	2004/01/20
		A R SEAL [L]	✓	2 / 90	2004/01/20
		B L SEAL [L]	✓	2 / 90	2004/01/20
		B R SEAL [L]	✓	2 / 90	2004/01/20
Autosampler	SIL-20AC	NEEDLE SEAL [times]	✓	100 / 40000	2004/01/20

	Display item	Description
①	Unit Name	Displays the names of the components connected to the system.
②	Unit Model	Displays the model names of the connected components.
③	Item	Displays the maintenance items.

	Display item	Description
	Result	
④		Displayed for items satisfying the recommended criterion (i.e., not requiring replacement).
		Displayed for items not satisfying the recommended criterion (i.e., requiring replacement).
	-	Displayed for components with no maintenance information.
⑤	Present/ Recommendation	Displays the usage up to the present date and the recommended usage limit value.
⑥	Date Last Replaced	Displays the year, month, and day of the last replacement.

5.3 Periodic Inspection and Maintenance

5.3.1 Periodic Inspection and Maintenance

It is necessary to perform periodic inspections of this instrument to ensure its safe use. It is possible to have these periodic inspections performed by Shimadzu service representatives on a contractual basis.

For information regarding the maintenance inspection contract, contact your Shimadzu representative.

5.3.2 Exterior Cleaning

If the instrument cover or front panel becomes dirty, wipe it clean with a soft dry cloth or tissue paper.

For persistent stains, clean the exterior using the following procedure.

- 1 Dip a piece of cloth in a dilute neutral detergent and twist firmly to remove excess liquid. Use this cloth to scrub the soiled area of the exterior surface of the instrument.
 - 2 Dip a piece of cloth into water and twist firmly to remove excess liquid. Use this cloth to wipe away all the remaining detergent. Use a dry cloth to remove all moisture from the exterior surface of the instrument.
-  Do not allow spilled water to remain on the instrument surface, and do not use alcohol or thinner-type solvents to clean the surfaces. These can cause rusting and discoloration.

5.4 Error Message

5.4.1 Errors at Power ON

After the power to the system controller is turned ON, a memory check is performed as part of internal initialization. If an abnormality is discovered, the following type of error message is displayed after login.

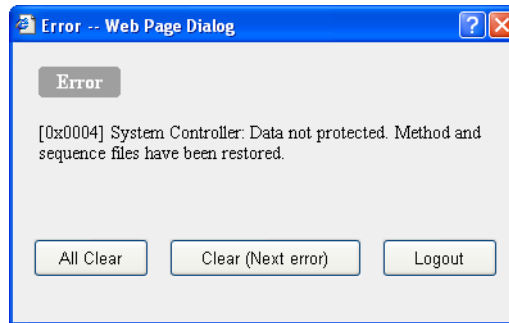

5.4.2 Operating Errors

If an error occurs in the system controller or in a connected component while the user is performing window operations, an error message is displayed. If LC-30A/20A-series components are connected, the buzzer sounds and the error is displayed at one of these components.

■ Error Window

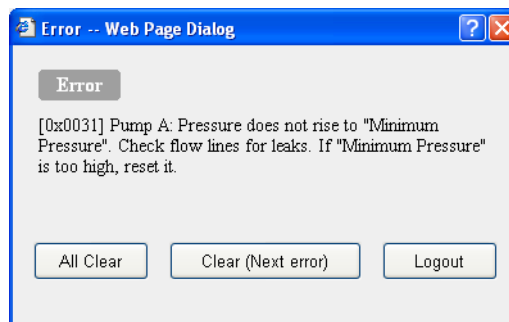

■ Error Level

The 3 types of error are described in the following table.

Error Message	Description
Warning	Urges the user to exercise caution.
Error	Indicates an error in the system.
Fatal error	Indicates a problem related to hardware. The message [Turn OFF the power.] is displayed.

● Warning

No processing is performed by the system controller. It becomes possible, however, to configure settings from the operating panel of the displayed component. Control is not possible from the system controller.

● Error

The error display can be cleared by clicking [All Clear] or [Clear (Next error)] in the error window.

This operation also clears the errors displayed at the solvent delivery module or other component at which the buzzer sounded when the error occurred.

If [System Protection] is set to [Enable] in the solvent delivery module configuration settings, solvent delivery may continue after an error occurs. Solvent delivery stops when [All Clear] or [Clear (Next error)] is pressed.

If an error occurs, the currently executed time program stops, and the operation of autosamplers and fraction collectors is interrupted. Also, operation according to the operation level is performed as described in the following table.

Level	Description
1	If [System Protection] is set to [Enable] in the solvent delivery module configuration settings, the column oven turns OFF and the solvent delivery module continues pumping at half the flow rate. If [System Protection] is set to [Disable], the column oven and the solvent delivery module both turn OFF.
2	The column oven and the solvent delivery module both turn OFF.
3	Neither the column oven nor the solvent delivery module turns OFF.

● Fatal error

Normal operation cannot be restored after a fatal error has occurred. The [All Clear] button and the [Clear (Next error)] button are not displayed for fatal errors. Only the [Logout] button is displayed. After logging out, turn OFF the power.

When a fatal error occurs, solvent delivery modules and column oven are turned OFF and current time program is stopped. Operation of autosampler and fraction collector is interrupted.

This page is intentionally left blank.